

# INSPIRE 1 PRO

## Quick Start Guide

V1.2

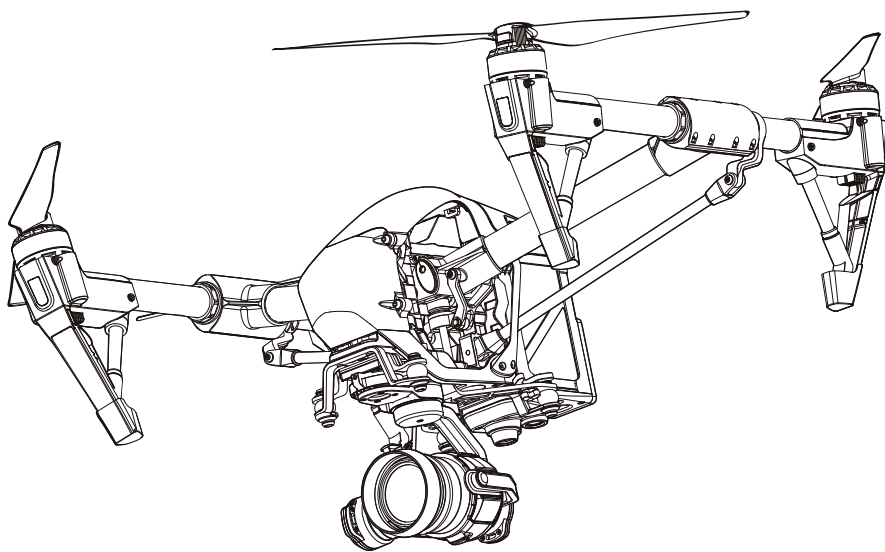

# INSPIRE 1 PRO

The Inspire 1 Pro features the Zenmuse X5 gimbal and camera equipped with a 15mm f/1.7 (35mm format equivalent 30mm) Micro Four Thirds interchangeable lens. It shoots sharp 16MP stills and stable video at up to 4K. The aircraft's retractable landing gear pulls up out of view, giving the camera an unobstructed 360 degree view of the world below.

Through the DJI GO app, the camera focus, shutter speed, aperture and ISO can be manually adjusted. The DJI Focus, a wireless follow focus system, can be linked to the remote controller of the Inspire 1 Pro for seamless and tactile camera control across the entire flight range.

An advanced flight controller makes the Inspire 1 Pro stable, safe and easy to fly indoors or out. The revolutionary Vision Positioning System (VPS) gives it the power to hover in position at low altitudes even without GPS. Like all DJI flight controllers, it is also able to return home if remote controller signal is lost or if the low battery warning is triggered.

The Inspire 1 Pro boasts a maximum flight speed 18m/s\* and a maximum flight time of 15 minutes\* using one fully charged 4500 mAh Intelligent Flight Battery.

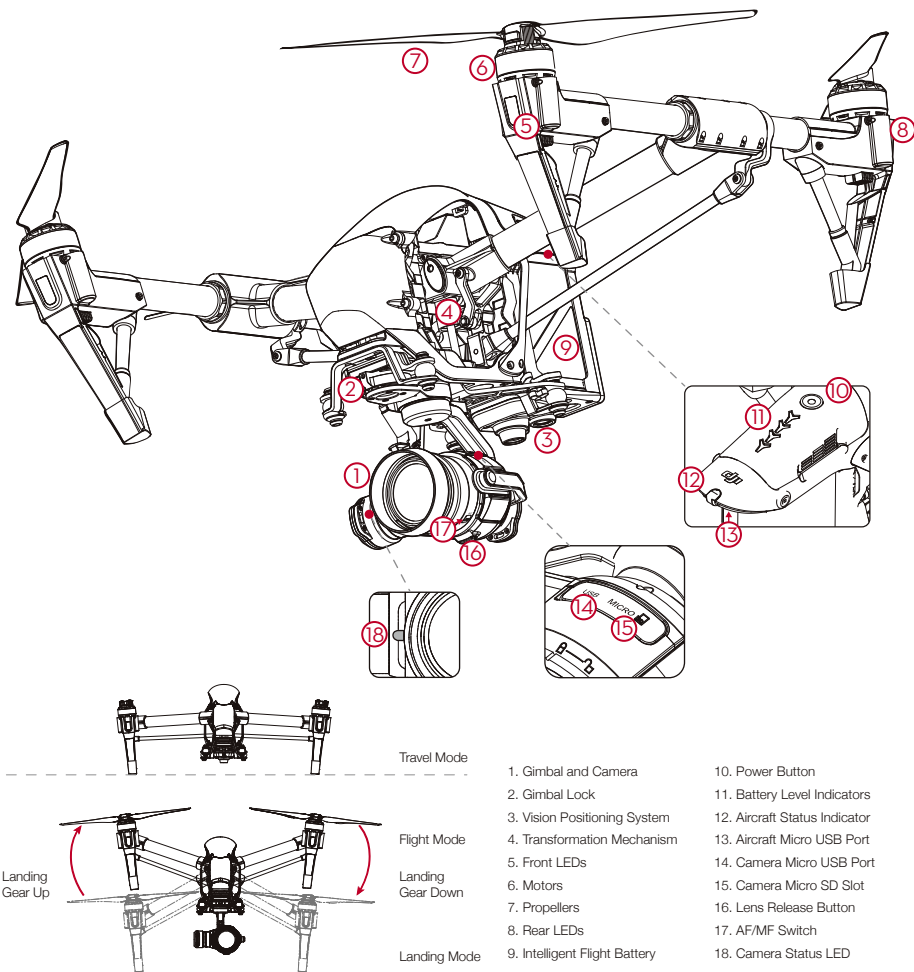

\* The maximum flight speed and maximum run-time (hovering state) were tested in a lab environment, at zero-level elevation and in windless conditions, and should be taken as reference only.

# Remote Controller

The maximum transmission distance of the Inspire 1 Pro remote controller is 16,400 feet (5 km)\*. The built-in LiPo battery powers the device for up to four hours in between charges.

An ergonomic design puts photo and video capturing, playback and gimbal control functions within comfortable reach, crucial when the aircraft is being operated. Important controls such as raising and lowering the landing gear and activating the Return-to-Home procedure can also be triggered with a tap of a button.

The Lightbridge HD video downlink is integrated into the remote controller, allowing real-time camera footage to be displayed in the DJI GO app. Dual remote controller mode makes it possible for the aircraft and camera to be operated on two separate controls, which have a communication range of up to 50 meters.

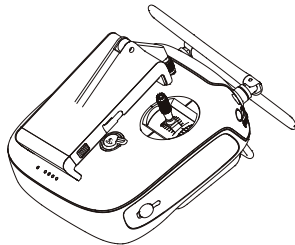

Folded

1. Power Button
2. Transformation Switch
3. Return-to-Home (RTH) Button
4. Control Sticks
5. Status LED
6. Battery Level LEDs
7. Power Port
8. Mobile Device Holder
9. Antennas
10. Handle Bar

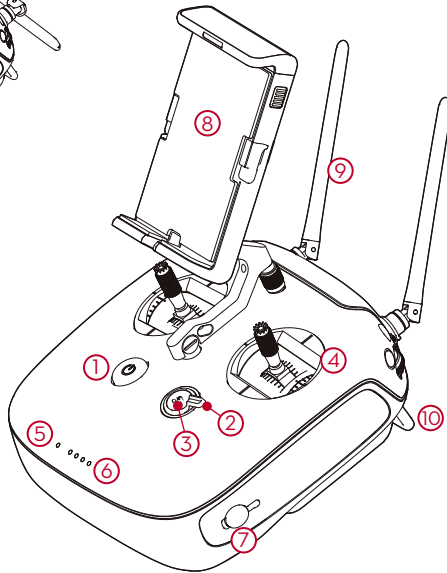

11. Gimbal Dial
12. Camera Settings Dial
13. Record Button
14. Flight Mode Switch
15. Shutter Button
16. Playback Button
17. Mini HDMI Port
18. Micro USB Port
19. CAN Bus Port
20. USB Port
21. C1 Button
22. C2 Button

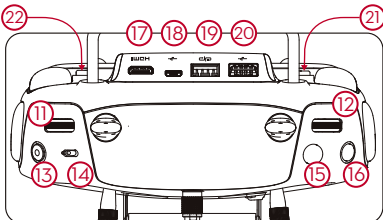

Connect your mobile device

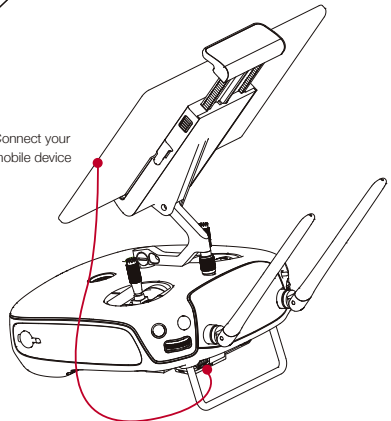

\* The maximum transmission distance was tested in a lab environment, and will vary greatly depending on your immediate area.

# Fly Safe

DJI encourages you to enjoy flying in a safe, responsible and smart way.

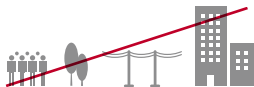

**DO NOT FLY** near or above people, near trees, power lines or buildings.



**DO MONITOR YOUR ALTITUDE** and fly under 400 feet (120 meters).

It is important to understand basic flight guidelines for the safety of both you and those around you. Refer to the Safety Guidelines and Disclaimer for more information.



**DO NOT FLY** in rain, snow, fog, and wind speeds exceeding 22 mph or 10 m/s.



**DO MAINTAIN LINE OF SIGHT** and avoid flying behind buildings or obstacles that block your view.



Learn more: <http://fllysafe.dji.com/no-fly>

- ⚠ Be very careful when flying 14,700 feet (4,500 meters) or more above sea level as the battery and aircraft performance may be reduced.
- The Inspire 1 Pro's compass and GPS will not work in Polar Regions. The aircraft will auto switch to ATTI Mode and use the VPS for positioning.

## ● Calibrating the Compass

Only calibrate the compass when the DJI GO app or the status indicator prompt you to do so. Observe the following rules when calibrating your compass:

1. DO NOT calibrate your compass where there is a chance of strong magnetic interference, such as magnetite, parking structures, and steel reinforcements underground.
2. DO NOT carry ferromagnetic materials with you during calibration such as cellular phones.
3. The DJI GO app will prompt you to resolve the compass issue if the compass is affected by strong interference after calibration is complete. Follow the prompted instructions to resolve the compass issue.

## ● Positioning Systems (P-Mode)

The aircraft uses GPS and a Vision Positioning System (VPS) to pinpoint its position and stabilize flight. It is strongly advised to fly in P-Mode which, depending on the GPS signal and aircraft altitude, has one of the following states:

**P-GPS:** GPS and VPS are used for positioning. The aircraft can return home.

**P-OPTI:** Only VPS is used for positioning (< 9.8 feet). The aircraft cannot return home.

**P-ATTI:** GPS and VPS are not available. The aircraft can maintain balance but will drift from side to side. It cannot return home.

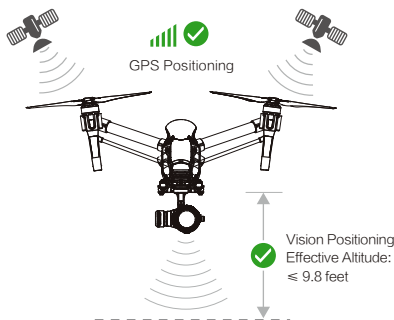

Toggle the flight mode switch on the remote controller to 'P' and wait for a stable satellite count before takeoff.

The effective altitude for the Vision Positioning System is below 9.8 feet. The Vision Positioning System will not work properly over surfaces that do not have pattern variations, over water or in low light conditions (< 100 lux).



## ● Return-to-Home

It is important to take off with a strong GPS signal (green bars) to ensure that the Home Point is recorded by the aircraft. The aircraft will automatically return to the Home Point in the following cases.

- Smart RTH:** The pilot presses the RTH button.
- Low Battery RTH:** The battery level is low or critically low.
- Failsafe RTH:** Remote controller signal is lost.

- ⚠ The aircraft will not avoid obstacles while it is returning to the Home Point, and an appropriate RTH altitude must be set before takeoff. You should also use the control sticks to guide the aircraft. Refer to the Safety Guidelines and Disclaimer for more details.

# Specifications

- Aircraft (Model: T600)**

Weight	2870 g (Battery and propellers included, Zenmuse X5 excluded) 3400 g (Battery, propellers and Zenmuse X5 included)
Max Takeoff Weight	3500 g
Max Tilt Angle	35°
Max Ascent Speed	5 m/s
Max Descent Speed	4 m/s
Max Speed	18 m/s (ATTI mode, no wind)
Max Service Ceiling Above Sea Level	14,700 feet (4,500 meters) (Software altitude limit: 400 feet above takeoff point) Approx. 15 minutes
Max Flight Time	
Operating Temperature	14° to 104° F (-10° to 40° C)

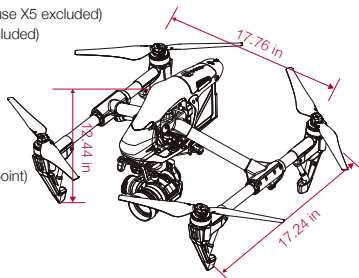

- Gimbal**

Angular Vibration Range	±0.02°
Controllable Range	Pitch: -90° to +30°, Pan: ±320°
Max Controllable Speed	Pitch: 120°/s, Pan: 180°/s

- Vision Positioning System**

Velocity Range	< 8 m/s @altitude 6.56 feet (2 m)
Altitude Range	0.16 - 16.4 feet (5-500 cm)
Operating Range	< 9.84 feet (300 cm)
Operating Environment	Surfaces with clear patterns and adequate lighting (> 15 lux)

- Camera (Name/Model: Zenmuse X5 / FC550)**

Sensor	Type 4/3 CMOS sensor; Effective pixels: 16M
Lens	DJI MFT 15mm f/1.7 ASPH, 72° FOV, 35 mm (30 mm format equivalent)
ISO Range	100-25600
Electronic Shutter Speed	8 to 1/8000 s
Max Resolution	4608x3456
Still Photography Modes	Single shot; Burst mode: 3/5/7 frames; Auto Exposure Bracketing (AEB): 3/5 bracketed frames at 0.7EV bias; Timelapse (3/5/7/10/20/30/60 sec)
Video Resolution	UHD: 4K (4096x2160) 24/25p, 4K (3840x2160) 24/25/30p, 2.7K (2704x1520) 24/25/30p FHD: 1920x1080 24/25/30/48/50/60p
Max Video Bitrate	60 Mbps
Supported File Systems	FAT32 (≤ 32 GB), exFAT (> 32 GB)
Photo Formats	JPEG, DNG (RAW)
Video Formats	MP4/MOV (MPEG-4 AVC/H.264)
Supported Storage Devices	Class 10 or UHS-1 or above Micro SD cards; Max capacity of 64GB
Operating Temperature	32° to 104° F (0° to 40° C)

- Remote Controller (Name: C1)**

Operating Frequency	922.7 MHz-927.7 MHz (Japan only); 5.725 GHz-5.825 GHz; 2.400 GHz-2.483 GHz
Max Transmitting Distance	FCC Compliant: 16,400 feet (5 km); CE Compliant: 11,483 feet (3.5 km) (unobstructed, free of interference)
Video Output Ports	USB, Mini HDMI
Operating Temperature	14° to 104° F (-10° to 40° C)
Battery	6000 mAh 2S LiPo

- Charger (Model: A14-100P1A)**

Voltage	26.3 V
Rated Power	100 W

- Intelligent Flight Battery (Model: TB47, Standard)**

Capacity	4500 mAh
Voltage	22.2 V
Battery Type	6S LiPo High voltage battery
Energy	99.9 Wh
Net Weight	570 g
Operating Temperature	14° to 104° F (-10° to 40° C)
Max Charging Power	180 W

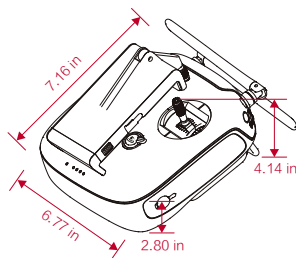

- Intelligent Flight Battery (Model: TB48, Optional)**

Capacity	5700 mAh
Voltage	22.8 V
Battery Type	6S LiPo High voltage battery
Energy	129.96 Wh
Net Weight	670 g
Operating Temperature	14° to 104° F (-10° to 40° C)
Max Charging Power	180 W

# Using INSPIRE 1 PRO

## 1. Download the DJI GO App

Search 'DJI GO' on the App Store or Google Play and download the app to your mobile device.



DJI GO app

## 2. Watch the Tutorial Videos

Watch the tutorial videos at [www.dji.com](http://www.dji.com) or in the DJI GO app.



Tutorial Videos

- ⚠️ • DJI GO supports iOS 8.0 (or later) or Android 4.1.2 (or later).

## 3. Check the Battery Levels

- Press once to check the battery level.
- Press once, again and hold to turn on/off.

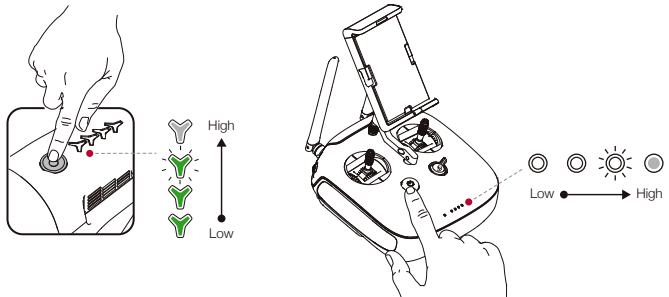

## 4. Charge the Batteries

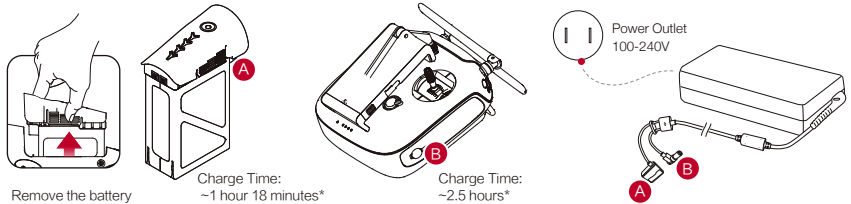

\* Provided charger

- ⚠️ • The Intelligent Flight Battery must be fully charged before using it for the first time.
- Only use the official DJI Inspire 1 Pro charger for your Intelligent Flight Battery and remote controller. Power off the Intelligent Flight Battery before charging.
- When charging is complete, the LED lights on the Intelligent Flight Battery and remote controller will turn off.

## 5. Prepare the Aircraft

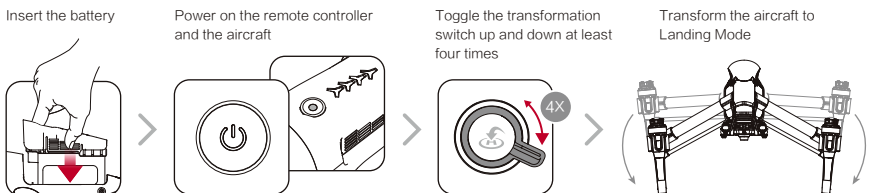

- ⚠️ • In Dual Remote Controller Mode, only the Master remote controller can transform the landing gear.
- DO NOT place the aircraft on rough or sound-absorbing surfaces (e.g. carpets) when transforming the landing gear.

## 6. Prepare the Remote Controller

Unfold the mobile device holder and the antennas.

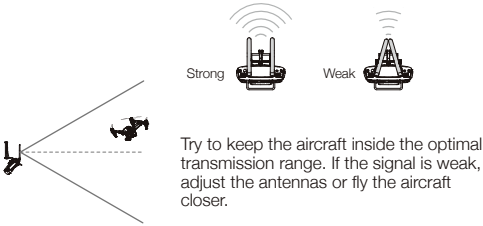

Optimal Transmission Range

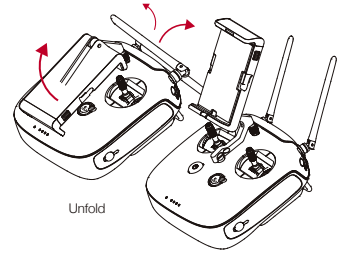
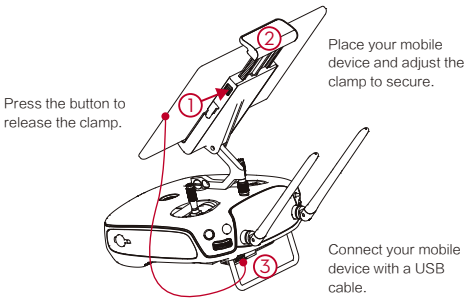

### Dual Remote Controllers

You will need to link the Master and Slave remote controllers.

On the Master RC, launch the DJI GO app and enter Camera View. Tap on the top of your screen to bring up the RC Settings. Set the RC Status as 'Master', and then enter the desired connection password.

Similarly on the Slave RC, set the RC Status to 'Slave'. Then tap Search for Master RC and connect to the Master RC with your preset password.

- DO NOT use other 2.4 GHz devices at the same time to avoid signal interference.
- DO NOT operate more than 3 aircrafts within in the same area (size equivalent to a soccer field) to prevent transmission interference.

## 7. Prepare the Camera

Align the two lens mount indices, and insert the lens into the camera body.

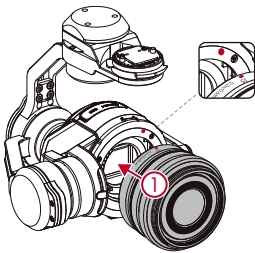

Rotate the lens clockwise until you hear a click.



Rotate the Lens Lock counterclockwise to lock it.

- Tighten the junction between the lens and camera body.
- Hold down the lens release button to loosen the junction when attaching and detaching the camera.

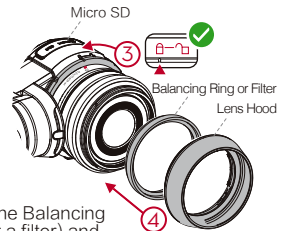

Mount the Balancing Ring (or a filter) and the lens hood. Insert the Micro SD card.

- Always set the camera lens to AF mode.
- While holding down the lens release button, rotate the camera lens counterclockwise to detach it.
- DO NOT mount the Balancing Ring and a filter at the same time.

## 8. Mount the Gimbal and Camera

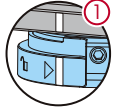

Rotate the Gimbal Lock to the unlocked position.

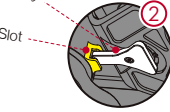
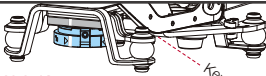

Align the key on the damping plate with the slot on the gimbal.



Align the white lines and insert the gimbal.

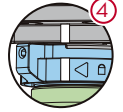

Rotate the Gimbal Lock to the locked position.

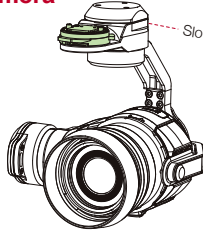

- ⚠ Be sure to remove the gimbal before transforming the aircraft to Travel Mode.
- Always power off the aircraft before mounting or removing the gimbal.

## 9. Preparing for Takeoff

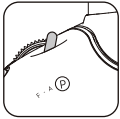

Toggle the Flight Mode Switch to the safest P-Mode.

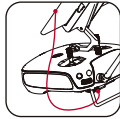

Connect your mobile device.

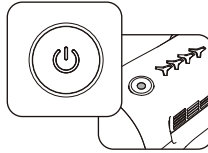

Power on the remote controller and aircraft.



Launch the DJI GO app and enter Camera View.

Pair the propellers and motors with arrows of the same color (red or white).

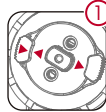
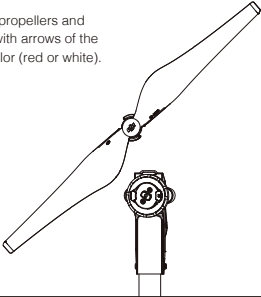

Rotate the propeller lock until the arrows are aligned and you hear a click.



Attach the propeller onto the motor.



Again, rotate the propeller lock until you hear a click.

- ⚠ • Ensure the propellers are mounted securely and correctly.

## 10. Controls

The stick mode is set to Mode 2 by default (left hand throttle). The left stick controls the aircraft's elevation and heading. The right stick controls the aircraft's forward, backward and lateral movements. The gimbal dial controls camera tilt.

Left Stick

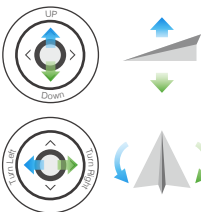

Right Stick

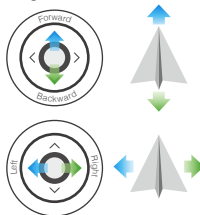

Gimbal Dial

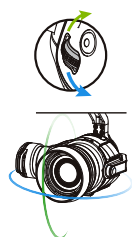

- ⚠ • You can change the stick mode in the DJI GO app.



## 11. Flight

### Safe to Fly (GPS)

Before taking off, ensure the Aircraft Status Bar in the DJI GO app indicates 'Safe to Fly (GPS)'.

In the DJI GO App:



#### Auto Takeoff

The aircraft will take off and hover at an altitude of 4 feet (1.2 meters).



#### Auto Landing

The aircraft will land vertically and stop its motors.



#### Return-to-Home

Brings the aircraft back to the Home Point. Tap again to stop the procedure.



- The aircraft will not avoid obstacles while it is returning to the Home Point, and an appropriate RTH altitude must be set before takeoff. You should also use the control sticks to guide the aircraft. Refer to the Safety Guidelines and Disclaimer for more details.

### Manual Takeoff

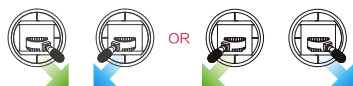

Combination Stick Command to start/stop the motors

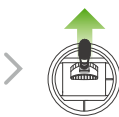

Left stick up (slowly) to take off

### Manual Landing

Ensure the landing gear is lowered before landing.



Raise



Lower

If you want to lower the landing gear but the switch is already in the 'down' position, toggle the switch up and down again.

### Return-to-Home (RC)



Same as the RTH button in the DJI GO app. Brings the aircraft back to the Home Point. Press and hold to initiate the RTH procedure. Press again to cancel.



Left stick down (slowly) until you touch the ground. Hold a few seconds to stop the motors.



- Rotating propellers can be dangerous. DO NOT start the motors in narrow spaces or when there are people nearby.
- Never perform the Combination Stick Command in mid-flight, or else the aircraft will crash.
- Always keep your hands on the remote controller so long as the motor is still spinning.
- After landing, power off the aircraft before turning off the remote controller.
- Take off from a flat surface in a wide open space, with the rear of the aircraft facing towards you.

## Appendix

### Aircraft Status Indicator

- slowly ... Safe to fly (GPS working).
- ... No GPS but VPS working.
- slowly ... P-ATTI or ATTI mode.
- quickly ... Not connected to remote controller.
- slowly ... Low battery level warning.
- quickly ... Critical low battery level warning.
- solid ... Critical error.
- ... compass calibration required.

### Remote Controller Status Indicator

- RC normal but not connected to aircraft.
- RC normal and connected to aircraft.
- RC Slave Mode and not connected to aircraft.
- RC Slave Mode and connected to aircraft.
- (↔ B ...) Low battery warning / RC error.
- (↔ B - B ...) RC idle for 5 minutes.

### Downloading Your Videos

- Compressed video and photo files are automatically stored on your mobile device while you are recording. You can view them in the Library section of the DJI GO app.
- For the best quality, download the original HD files through the app or using an SD card reader.

※ This content is subject to change without prior notice.

Download the detailed user manual at:

[www.dji.com/product/inspire-1-pro-and-raw](http://www.dji.com/product/inspire-1-pro-and-raw)

©2015 DJI. All Rights Reserved.

Designed by DJI. Printed in China.

# INSPIRE 1 PRO

Creativity Unleashed