

PHANTOM 4 RTK

Quick Start Guide

v1.2



Phantom 4 RTK

The PHANTOM™ 4 RTK is a smart mapping and imaging drone capable of highly accurate mapping functions. The aircraft has a built-in DJI™ Onboard D-RTK*, which provides precision data for centimeter-level positioning accuracy. Multi-directional obstacle sensing is enabled by forward, rear, and downward vision and infrared sensors*. The camera features a 1-inch 20-megapixel CMOS sensor housed within a high stability gimbal. When it comes to mapping, the high-performance mechanical shutter eliminates rolling shutter distortion when capturing images at speed. Image data can be used to generate maps for field planning when operating a DJI AGRAS™ aircraft. Users can also import photos to the DJI PC GS Pro application or third-party mapping software to composite highly accurate maps for different applications.

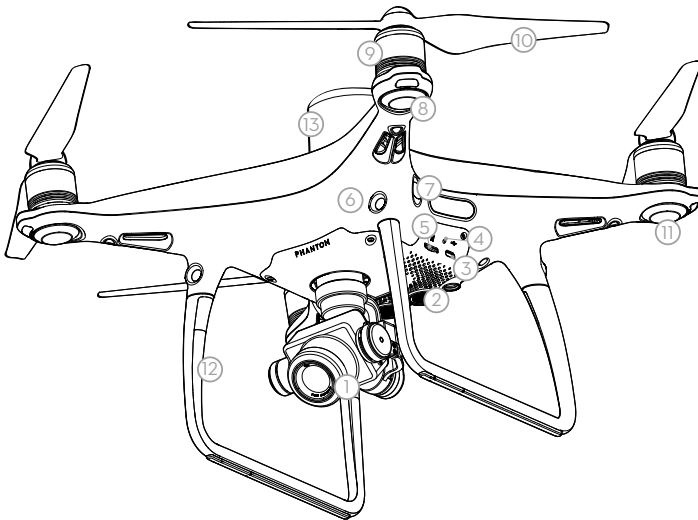

- | | |
|--|--------------------------------|
| 1. Gimbal and Camera | 10. Propellers |
| 2. Downward Vision System | 11. Aircraft Status Indicators |
| 3. Micro USB Port | 12. OCUSSYNC™ Antennas |
| 4. Camera/Linking Status Indicator and Link Button | 13. Onboard D-RTK™ Antenna |
| 5. Camera microSD Card Slot | 14. Rear Vision System |
| 6. Forward Vision System | 15. Intelligent Flight Battery |
| 7. Infrared Sensing System | 16. Power Button |
| 8. Front LEDs | 17. Battery Level Indicators |
| 9. Motors | |

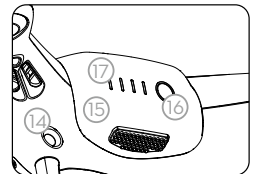

* This should be used with Network RTK service, a DJI D-RTK 2 High-Precision GNSS Mobile Station (purchased additionally) or post-processed kinematic (PPK) data (recommended when RTK signal is weak during operation). The Vision and Infrared Sensing Systems are affected by surrounding conditions. Read the Disclaimer and Safety Guidelines to learn more.

Remote Controller

The Phantom 4 RTK remote controller has a transmission range of up to 4.3 mi (7 km) * with controls for camera tilt and photo capture. DJI OcuSync is built into the remote controller, transmitting live HD imaging from the camera directly. Simply tap the screen in the DJI GS RTK app or import KML/KMZ files to plan an operation for convenient project management. Users can also connect the remote controller to a PC to access DJI PC GS Pro for planning and executing operations. The remote controller's Multi-Aircraft Control mode can be used to coordinate the operation of up to five aircraft at the same time, enabling pilots to work more efficiently. Replaceable batteries can be easily hot-swapped and the antennas are easily removable for quick maintenance.

1. Power Button
2. RTH Button
3. Control Sticks
4. Speaker
5. Lanyard Attachment
6. Status LED
7. Battery Level LEDs
8. USB-C Port
9. 3.5 mm Audio Jack
10. MicroSD Card Slot
11. Display Device
12. Sleep/Wake Button
13. Antennas

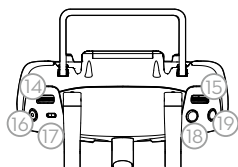
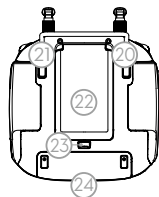
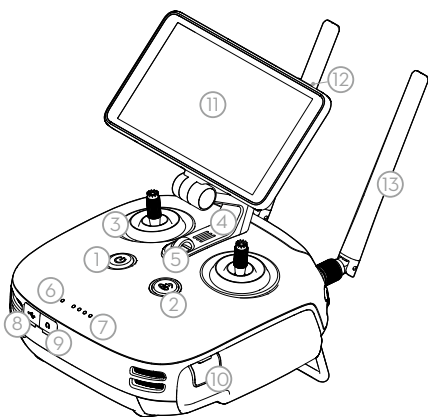

14. Gimbal Dial
15. Aircraft Control Switch Dial
16. Record Button
17. Pause Switch
18. Shutter Button
19. Reserved Button

20. Button C1 (customizable)
21. Button C2 (customizable)
22. Battery Compartment Cover
23. Battery Compartment Cover Lock
24. Dangle Compartment Cover

The figure below shows the function that each control stick movement performs, using Mode 2 as an example. The left stick controls the aircraft's altitude and heading, while the right stick controls its forward, backward, left and right movements. The gimbal dial controls the camera's tilt.

Left Stick

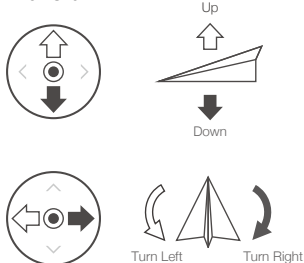

Right Stick

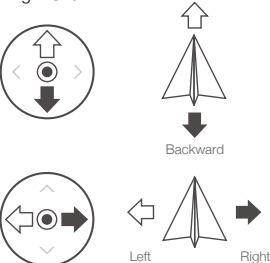

Gimbal Dial

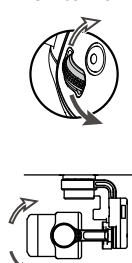

* The remote controller is able to reach its maximum transmission distance (FCC) in a wide open area with no Electro-Magnetic Interference, and at an altitude of about 400 feet (120 meters).

Using Phantom 4 RTK

1. Mount the Remote Controller Battery

The remote controller uses an easily removable interchangeable Intelligent Battery for long-term operation.

- 1 Slide the battery compartment cover lock on the back of the remote controller down to open the cover.
- 2 Insert the Intelligent Battery into the compartment and push it to the top.
- 3 Close the cover.

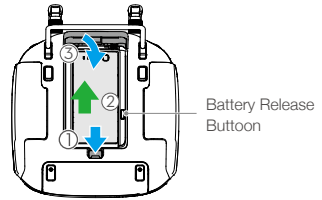

- To remove the Intelligent Battery, open the cover, press and hold the battery release button, then push the battery downward.

2. Mount the Dongle and SIM Card



- The Phantom 4 RTK remote controller can access the Internet using a 4G dongle with SIM card or Wi-Fi signal. For UK, EU, ACUK, or ACEU versions, a Network RTK server can only be accessed using a 4G dongle with SIM card. For AU or AFUS versions, using a 4G dongle with SIM card is recommended, but a Wi-Fi signal can also be used. To confirm the version of your unit, please view the version code after the product name on the label on the product packaging. When uploading or downloading system logs or operation data, using a Wi-Fi signal for Internet access is recommended.
- Only use a DJI approved dongle.
- The dongle supports various network standards. Use a SIM card that is compatible with the chosen mobile network provider and select a mobile data plan according to the planned level of usage.
- The dongle and SIM card are used to enable the remote controller to access to specific networks and platforms, such as the DJI AG platform. Be sure to mount them correctly, or else network access will not be available.

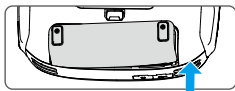

Lift the dongle compartment cover at the gap at its lower right corner, then remove it.

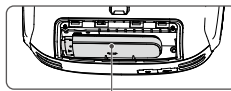

Insert the dongle into the USB port with the SIM card inserted into the dongle and test.*

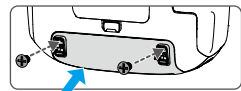

Re-mount the cover. To secure the cover, open the silicone protectors on it, insert and tighten two Phillips screws, then close the protectors.

* Test procedure: Press the remote controller power button once, then press again and hold to turn the remote controller on. In the DJI GS RTK app tap => and select **Network Diagnostics**. If the statuses of all the devices in the network chain are shown in green the dongle and SIM card are functioning properly.

3. Check the Battery Levels

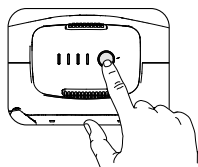

Low → High

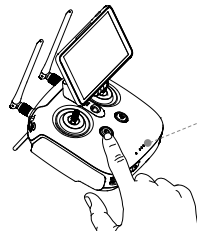
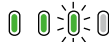

Low → High



Press once to check the battery level. Short press once, then long press and hold to turn on/off.

4. Charge the Batteries

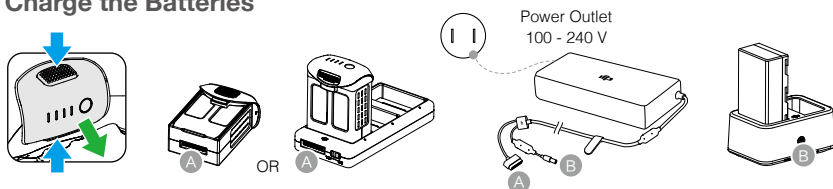

- ⚠ Fully charge the batteries before first-time use.
- Ensure to connect the Intelligent Flight Batteries to the charging hub as shown in the figure above.
- Ensure that the Mode Switch of the Intelligent Flight Battery charging hub is set to the **Charging Mode** position.

5. Prepare the Remote Controller

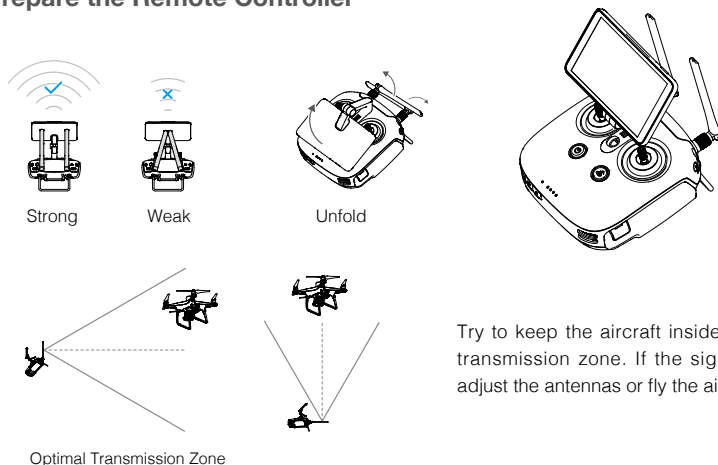

6. Prepare for Takeoff

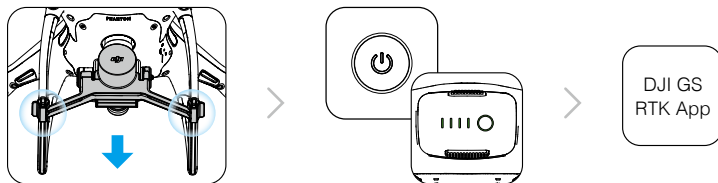

Remove the gimbal clamp from the camera.

Power on the remote controller and the aircraft.

Enter the DJI GS RTK app.



When using your Phantom 4 RTK for the first time, activate it using the DJI GS RTK app. Ensure that the remote controller has access to the Internet.



Black propeller rings go on motors with black dots.

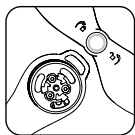

Silver propeller rings go on motors without black dots.



Press the propeller down onto the mounting plate and rotate in the lock direction (clockwise) until secure.

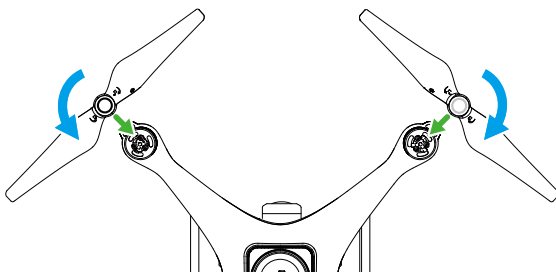

- Check that the propellers are secure before each flight.

7. Flight

Ready to Go (RTK)

Before taking off, make sure the Aircraft Status Bar in the DJI GS RTK app indicates Ready to Go (RTK)* or Ready to Go (GNSS).

Takeoff

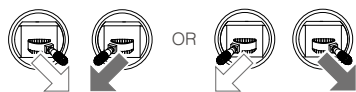

Combination Stick Command to start/stop the motors

OR

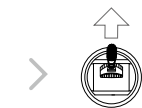

Left stick (in Mode 2) up slowly to take off

Landing



Left stick down slowly until you touch the ground

Hold for 3 seconds to stop the motors



- Spinning propellers can be dangerous. Stay away from spinning propellers and motors. DO NOT start the motors in confined spaces or when there are people nearby.
- Always keep your hands on the remote controller when the motors are spinning.
- **Stopping motors mid-flight: Perform the CSC to stop the motors. This feature is disabled by default. It can be enabled in the app. Only stop motors mid-flight in emergency situations when doing so can reduce the risk of damage or injury.**



It is important to understand basic flight guidelines, for the safety of both you and those around you. Do not forget to read the Disclaimer and Safety Guidelines.

* RTK positioning is recommended. Go to DJI GS RTK > Fly > ... > RTK to enable RTK module and select a method for receiving RTK signals.

8. Start Operations

Photogrammetry and waypoint actions can be performed using both PC GS Pro software and the DJI GS RTK app. The following example includes instructions for photogrammetry operation using the DJI GS RTK app. Refer to PC GS Pro User Manual for details (if in use).



Tap **Plan** on the main screen, select **Photogrammetry***



Tap the map to add edge points, drag to adjust their positions



Settings: altitude, speed, completion action, camera, and advanced settings



Tap **Save**, add name and remark, then tap **OK**



Use the operation**



Tap  in the Camera View for camera settings



Tap **Start**



Slide the slider to start the operation

* Users can also import KML/KMZ files to the app through a microSD card to plan photogrammetry operations. Refer to the Phantom 4 RTK User Manual for details.

** Select the operation again via the following method if the operation was not used immediately. Go to DJI GS RTK main screen > Fly >  on the left, select the operation from the planning list, and tap **Invoke**.



- Only take off in open areas.
- An operation can be paused by toggling the Pause Switch. The aircraft will hover and record the breakpoint, and then the aircraft can be controlled manually. To continue the operation, select it from the list again and then resume. The aircraft will automatically return to the breakpoint and resume the operation.
- The aircraft will return to the Home Point automatically once the operation is complete. Instead of RTH, the aircraft can also be set to perform other flight actions within the app.

9. Applications



Field Planning

Import aerial photos into PC GS Pro to perform map post-processing. Then plan the field in PC GS Pro. Use a microSD card to import the plan file from PC GS Pro into the Agras MG-1S Advanced / MG-1P series remote controller. Refer to corresponding user manuals for more details.



High Accuracy Mapping

Import the original aerial photos into PC GS Pro and perform map post-processing to produce a high-accuracy map. Please refer to the PC GS Pro User Manual for more details.

Visit the link below to learn more about PC GS Pro:
<http://www.dji.com/pc-gs-pro>

Specifications

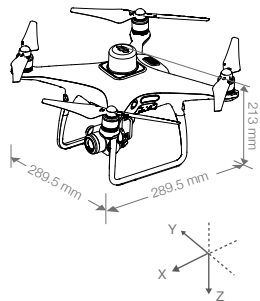

• Aircraft	
Weight (Battery & Propellers Included)	1391 g
Max Service Ceiling Above Sea Level	19685 ft (6000 m)
Max Ascent Speed	6 m/s (automatic flight); 5 m/s (manual control)
Max Descent Speed	3 m/s
Max Speed	31 mph (50 kph) (P-mode); 36 mph (58 kph) (A-mode)
Max Flight Time	Approx. 30 minutes
Operating Temperature	32° to 104° F (0° to 40° C)
Operating Frequency	2.400 GHz to 2.483 GHz (Europe, Japan, Korea) 5.725 GHz to 5.850 GHz (United States, China)
EIRP	2.4 GHz CE (Europe) / MIC (Japan) / KCC (Korea): < 20 dBm 5.8 GHz FCC (United States) / SRRC (Mainland China) / NCC (Taiwan, China): < 26 dBm
Hover Accuracy Range	RTK enabled and functioning properly: Vertical: ±0.1 m; Horizontal: ±0.1 m RTK disabled: Vertical: ±0.1 m (with vision positioning); ±0.5 m (with GNSS positioning) Horizontal: ±0.3 m (with vision positioning); ±1.5 m (with GNSS positioning)
Image Position Offset	The position of the camera center is relative to the phase center of the onboard D-RTK antenna under the aircraft body's axis: (36, 0, and 192 mm) already applied to the image coordinates in Exif data. The positive x, y, and z axes of the aircraft body point to the forward, rightward, and downward of the aircraft, respectively.
• GNSS	
Single-Frequency High-Sensitivity GNSS	GPS + BeiDou + Galileo* (Asia); GPS + GLONASS + Galileo* (other regions)
Multi-Frequency Multi-System High-Precision RTK GNSS	Frequency Used GPS: L1/L2; GLONASS: L1/L2; BeiDou: B1/B2; Galileo*: E1/E5 First-Fixed Time: < 50 s Positioning Accuracy: Vertical 1.5 cm + 1 ppm (RMS); Horizontal 1 cm + 1 ppm (RMS). 1 ppm indicates error with a 1 mm increase over 1 km of movement. Velocity Accuracy: 0.03 m/s
• Mapping Functions	
Mapping Accuracy**	Mapping accuracy meets the requirements of the ASPRS Accuracy Standards for Digital Orthophotos Class III.
Ground Sample Distance (GSD)	(H/36.5) cm/pixel, H indicates the aircraft altitude relative to the shooting scene (unit: m)
Acquisition Efficiency	Max operating area of approx. 1 km ² for a single flight (at an altitude of 182 m, i.e., GSD is approx. 5 cm/pixel, meeting the requirements of the ASPRS Accuracy Standards for Digital Orthophotos Class III).
• Gimbal	
Controllable Range	Pitch: -90° to +30°
• Vision System	
Velocity Range	≤ 31 mph (50 kph) at 6.6 ft (2 m) above ground with adequate lighting
Altitude Range	0 - 33 ft (0 - 10 m)
Operating Range	0 - 33 ft (0 - 10 m)
Obstacle Sensory Range	2 - 98 ft (0.7 - 30 m)
Operating Environment	Surfaces with clear patterns and adequate lighting (> 15 lux)
• Infrared Sensing System	
Obstacle Sensory Range	0.6 - 23 ft (0.2 - 7 m)
Operating Environment	Surface with diffuse reflection material, and reflectivity > 8% (such as wall, trees, humans, etc.)
• Camera	
Sensor	1" CMOS; Effective pixels: 20M
Lens	FOV (Field of View) 84°, 8.8 mm (35 mm format equivalent: 24 mm), f/2.8 - f/11, auto focus at 1 m - ∞
ISO Range	Video: 100 - 3200 (Auto), 100 - 6400 (Manual); Photo: 100 - 3200 (Auto), 100 - 12800 (Manual)

* supported later

** The actual accuracy depends on surrounding lighting and patterns, aircraft altitude, mapping software used, and other factors when shooting.

Mechanical Shutter	8 - 1/2000 s
Electronic Shutter	8 - 1/8000 s
Max Image Size	4864x3648 (4:3); 5472x3648 (3:2)
Video Recording Modes	H.264, 4K: 3840x2160 30p
Photo	JPEG
Video	MOV
Supported File Systems	FAT32 (≤ 32 GB); exFAT (> 32 GB)
Supported SD Cards	microSD, Max Capacity: 128 GB. Class 10 or UHS-1 rating required
Operating Temperature	32° to 104° F (0° to 40° C)
• Remote Controller	
Operating Frequency	2.400 GHz to 2.483 GHz (Europe, Japan, Korea) 5.725 GHz to 5.850 GHz (United States, China)
EIRP	2.4 GHz CE / MIC / KCC: < 20 dBm 5.8 GHz FCC / SRRC / NCC: < 26 dBm
Max Transmission Distance	FCC / NCC: 4.3 mi (7 km); CE / MIC / KCC / SRRC: 3.1 mi (5 km) (Unobstructed, free of interference)
Power Consumption	16 W (typical value)
Display Device	5.5 inch screen, 1920x1080, 1000 cd/m ² , Android system, 4G RAM + 16G ROM
Operating Temperature	32° to 104° F (0° to 40° C)
• Intelligent Flight Battery (PH4-5870mAh-15.2V)	
Capacity	5870 mAh
Voltage	15.2 V
Battery Type	LiPo 4S
Energy	89.2 Wh
Net Weight	468 g
Operating Temperature	14° to 104° F (-10° to 40° C)
Max Charging Power	160 W
• Intelligent Flight Battery Charging Hub (PHANTOM 4 CHARGING HUB)	
Voltage	17.5 V
Operating Temperature	41° to 104° F (5° to 40° C)
• Remote Controller Intelligent Battery (WB37-4920mAh-7.6V)	
Capacity	4920 mAh
Voltage	7.6 V
Battery Type	LiPo 2S
Energy	37.39 Wh
Operating Temperature	-4° to 104° F (-20° to 40° C)
• Intelligent Battery Charging Hub (WCH2)	
Input Voltage	17.3 to 26.2 V
Output Voltage and Current	8.7 V, 6 A; 5 V, 2 A
Operating Temperature	41° to 104° F (5° to 40° C)
• AC Power Adapter (PH4C160)	
Voltage	17.4 V
Rated Power	160 W

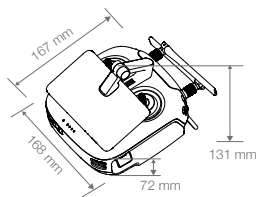

Download the user manual for more information:

<http://www.dji.com/phantom-4-rtk>

※ This Quick Start Guide is subject to change without prior notice.

PHANTOM is a trademark of DJI.
Copyright © 2018 DJI All Rights Reserved.

Designed by DJI. Printed in China.

PHANTOM 4 RTK