

MAVIC 2 ENTERPRISE

Dual with Smart Controller

Quick Start Guide

快速入门指南

快速入門指南

クイックスタートガイド

퀵 스타트 가이드

Kurzanleitung

Guía de inicio rápido

Guide de démarrage rapide

Guida di avvio rapido

Snelstartgids

Guia de início rápido

Guia de Início Rápido

Краткое руководство пользователя

v1.2

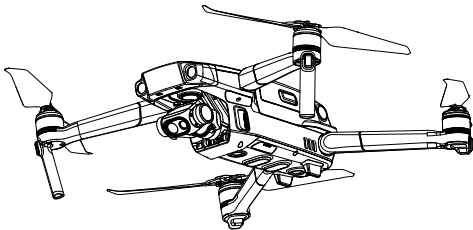

Contents

EN	Quick Start Guide	2
CHS	快速入门指南	12
CHT	快速入門指南	22
JP	クイックスタートガイド	32
KR	퀵 스타트 가이드	42
DE	Kurzanleitung	52
ES	Guía de inicio rápido	62
FR	Guide de démarrage rapide	72
IT	Guida di avvio rapido	82
NL	Snelstartgids	92
PT-PT	Guia de início rápido	102
PT-BR	Guia de Início Rápido	112
RU	Краткое руководство пользователя	122

Aircraft

The DJI™ MAVIC™ 2 Enterprise Dual features omnidirectional Vision Systems and Infrared Sensing Systems*, and comes with a fully stabilized 3-axis gimbal camera with a FLIR longwave infrared thermal camera and a visual camera, providing both infrared and visual images simultaneously. DJI signature technologies such as Obstacle Sensing help you fly and capture complex shots effortlessly. Additional features like the built-in AirSense makes you aware of your surrounding airspace, and password protection helps you maintain secure access to your aircraft and protect your data. The Mavic 2 Enterprise also has attachable modular accessories like the M2E Spotlight, M2E Beacon and M2E speaker that are purpose built for various applications. The Mavic 2 Enterprise boasts a maximum flight speed of 44.7 mph (72 kph) and a maximum flight time** of 31 minutes.

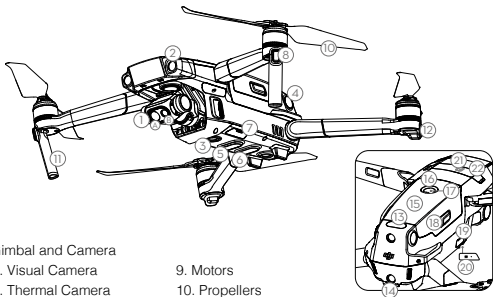

- | | | |
|--|--|--|
| 1. Gimbal and Camera | | |
| A. Visual Camera | | |
| B. Thermal Camera | | |
| 2. Forward Vision System | | |
| 3. Downward Vision System | | |
| 4. Lateral Vision System | | |
| 5. Downward Infrared Sensing System | | |
| 6. Auxiliary Bottom Light | | |
| 7. MicroSD Card Slot | | |
| 8. Front LEDs | | |
| 9. Motors | | |
| 10. Propellers | | |
| 11. Antennas | | |
| 12. Aircraft Status Indicator | | |
| 13. Upward Infrared Sensing System | | |
| 14. Backward Vision System | | |
| 15. Intelligent Flight Battery | | |
| 16. Battery Level LEDs | | |
| 17. Power Button | | |
| 18. Battery Buckles | | |
| 19. USB-C Port | | |
| 20. Link Button/Linking Status Indicator | | |
| 21. Extended Port (to connect accessories) | | |
| 22. Extended Port Cover | | |

* The Vision Systems and Infrared Sensing Systems are affected by surrounding conditions. Read the Disclaimer and Safety Guidelines, User Manual, and watch the tutorial videos on the official DJI website to learn more. <http://www.dji.com/mavic-2-enterprise>

** Maximum flight time was tested in an environment with no wind while flying at a consistent 15.5 mph (25 kph). This value is for reference only.

DJI Smart Controller

The DJI Smart Controller is a remote controller built with DJI's long-range transmission technology OCUSSYNC™ 2.0, offering a maximum transmission range of 6.2 mi (10 km) and provides a live HD view from the aircraft's camera. The Smart Controller comes with a number of aircraft and gimbal controls as well as customizable buttons and has a built-in 5.5-inch high-brightness screen with multiple functions such as Bluetooth and GNSS. Connection to the Internet via Wi-Fi is also supported. The Smart Controller has a maximum working time of 2.5 hours*.

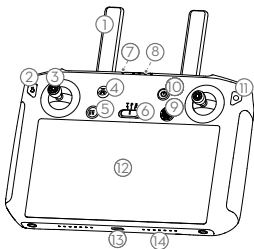

1. Antennas
2. Back Button / Function Button
3. Sticks
4. RTH Button
5. Flight Pause Button
6. Flight Mode Switch
7. Status LED
8. Battery Level LEDs
9. 5D Button
10. Power Button
11. Confirm Button / Customizable Button C3
12. Touch Screen
13. USB-C Port
14. Microphone

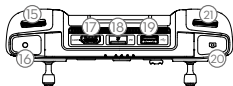

15. Gimbal Dial
16. Record Button
17. HDMI Port
18. MicroSD Card Slot
19. USB-A Port
20. Focus / Shutter Button
21. Aperture/Shutter Adjustment Dial

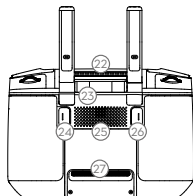

22. Air Vent
23. Sticks Storage Slot
24. Customizable Button C2
25. Speaker
26. Customizable Button C1
27. Air Intake

* The Smart Controller is able to reach its maximum transmission distance (FCC) in a wide-open area with no electromagnetic Interference at an altitude of about 400 ft (120 m).

The maximum runtime is tested in a laboratory environment. This value is for reference only.

1. Watch the Tutorial Videos

Watch the tutorial videos at www.dji.com/mavic-2-enterprise/info#video.



Tutorial videos

2. Preparing the Aircraft

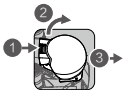

Remove the gimbal cover from the camera.



Unfold the front arms.



Unfold the rear arms.

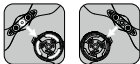

Marked

Unmarked

Match the propellers to motors.



Press the propellers down firmly and rotate in the lock direction.



Unfolded



Unfold the front arms and the propellers before the rear ones. All arms and propellers must be unfolded before takeoff.

3. Charging the Batteries

Use the provided charger to fully charge the Intelligent Flight Battery before first use.

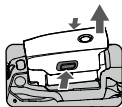

Remove the Intelligent Flight Battery

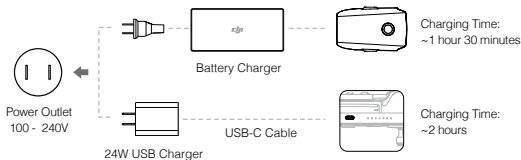

Please use the official 24W USB charger to charge the Smart Controller. When a standard 24W USB charger is not available, it is recommended to use an FCC/CE certified USB charger rated 12V/2A.

• Checking the Battery Levels and Powering On/Off

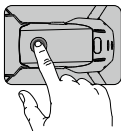

Press once to check the battery level.
Press, then press and hold to turn on/off.

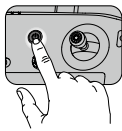

Low ————— High

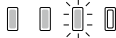

Press once to check the battery level on the LCD screen.

Press once, then press and hold to turn on/off the remote controller.



Install the battery to the aircraft and power it on. Once the battery temperature is lower than 6° C, it will auto heat to maintain a temperature between 8-10° C. Refer to the User Manual for more details.

4. Preparing the Remote Controller



Lift the antennas



Remove the sticks



Rotate to attach the sticks

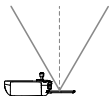
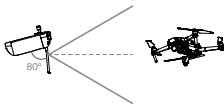
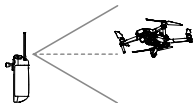

The optimal transmission range is shown above. Ensure the antennas are facing towards the aircraft. When the angle between the antennas and the back of the Smart Controller is 80° or 180° , the connection between the Smart Controller and the aircraft can reach its optimal performance.

The illustrations above show situations where the operator and aircraft are far away.



- Ensure the control sticks are firmly mounted.
- In real operation, the DJI Pilot app will prompt to warn that the transmission signal is weak, and please adjust the antennas to ensure that the aircraft is back to the optimal transmission range.

5. Preparing for Takeoff



Power on the remote controller



Power on the aircraft



Launch DJI Pilot



Internet

Use a DJI account to activate the aircraft and the Smart Controller. Activation requires an internet connection. Before activating the aircraft in DJI Pilot, power on the Smart Controller and follow the prompts to activate.



Set a password for the aircraft in the DJI Pilot app to ensure secure access and protect your onboard data.

6. Flight

Before taking off, make sure the Aircraft Status Bar in DJI Pilot displays "Ready to Go".

Ready to Go (GPS)

• Manual Takeoff / Landing

Combination stick command to start/stop the motors



Left stick up (slowly) to take off



Left stick down (slowly) until you touch the ground
Hold a few seconds to stop the motors



Only stop motors mid-flight in emergency situations when doing so can reduce the risk of damage or injury. The method to stop the motor can be set in DJI Pilot.

• Remote Controller Operation

The default flight control is known as Mode 2. The left stick controls the aircraft's altitude and heading, while the right stick controls its forward, backward, left and right movements. The gimbal dial controls the camera's tilt.

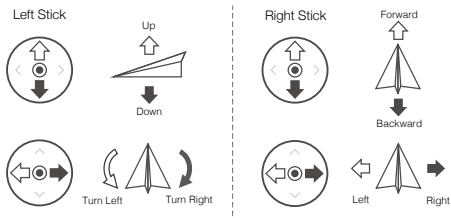

- Always set an appropriate RTH altitude before takeoff. When the aircraft is returning to the Home Point, you should guide it with the control sticks.
- Press the Flight Pause button for emergency braking during flight.

* Modular Accessories



M2E Beacon



M2E Spotlight



M2E Speaker

7. Fly Safe



Fly in Open Areas

+



Strong GPS Signal

+



Maintain Line of Sight

+



Fly Below 400 Feet (120 m)



Avoid flying over or near obstacles, crowds, high voltage power lines, trees or bodies of water.

DO NOT fly near strong electromagnetic sources such as power lines and base stations as it may affect the onboard compass.



DO NOT use the aircraft in adverse weather conditions such as rain, snow, fog and wind speeds exceeding 10 m/s or 22 mph.



Stay away from the rotating propellers and motors.



No Fly Zone

Learn more at:
<http://flysafe.dji.com/no-fly>



It's important to understand basic flight guidelines, for the safety of both you and those around you. Don't forget to read the **Disclaimer and Safety Guidelines**.

Specifications

• Aircraft

Weight	899 g
Max Speed	44.7 mph (72 kph) in Sport mode without wind
Max Service Ceiling Above Sea Level	19685 ft (6000 m)
Operating Temperature	14° to 104° F (-10° to 40° C)
GNSS	GPS + GLONASS
Operating Frequency	2.4-2.4835 GHz; 5.725-5.850 GHz
Transmitter Power (EIRP)	2.4 GHz FCC: ≤26 dBm; CE/MIC: ≤20 dBm; SRRC: ≤20 dBm 5.8 GHz FCC: ≤26 dBm; CE: ≤14 dBm; SRRC: ≤26 dBm
Internal Storage	24 GB

• Gimbal

Controllable Range	Pitch: -90° to +30°
--------------------	---------------------

• Thermal Camera

Sensor	Uncooled VOx Microbolometer
Lens	HFOV: 57° Aperture: f/1.1
Pixel Pitch	12 μm
Spectral Band	8-14 μm
Image Size	640×480 (4:3); 640×360 (16:9)
Still Photography Modes	Single shot Burst shooting: 3/5/7 frames Interval (2/3/5/7/10/15/20/30/60 s) 640×360 @8.7fps
Video Recording Modes	High Gain: Max ±5% (typical) Low Gain: Max ±10% (typical)
Accuracy	High Gain: -10° to +140°C Low Gain: -10° to +400°C
Scene Range	JPEG
Photo	MP4, MOV (MPEG-4 AVC/H.264)
Video	

• Visual Camera

Sensor	1/2.3" CMOS; Effective pixels: 12M
Lens	FOV: approx. 85° 35 mm format equivalent: 24 mm Aperture: f/2.8 Focus: 0.5 m to ∞
ISO Range	Video: 100-12800 (auto) Photo: 100-1600 (auto)
Max Image Size	4056×3040 (4:3); 4056×2280 (16:9)
Still Photography Modes	Single shot Burst shooting: 3/5/7 frames Interval (2/3/5/7/10/15/20/30/60 s)
Video Recording Modes	4K Ultra HD: 3840×2160 30p 2.7K: 2688×1512 30p FHD: 1920×1080 30p
Max Video Bitrate	100 Mbps
Photo	JPEG
Video	MP4, MOV (MPEG-4 AVC/H.264)

• Smart Controller

Battery	5000mAh @ 7.2V
---------	----------------

Operation Temperature Range	-4° to 104° F (-20° to 40° C)
Storage Capacity	ROM 16GB + Scalable (microSD card)
Ocusync 2.0	
Operation Frequency Range	2.4-2.4835 GHz; 5.725-5.850 GHz
Max Transmission Distance	FCC: 10 km; CE/MIC: 6 km; SRRC: 6 km (Unobstructed, free of interference)
Transmitter Power (EIRP)	2.4 GHz FCC: ≤25.5 dBm; CE/MIC: ≤18.5 dBm; SRRC: ≤19 dBm 5.8 GHz FCC: ≤25.5 dBm; CE: ≤12.5 dBm; SRRC: ≤18.5 dBm
Wi-Fi	
Protocol	Wi-Fi Direct, WiFi Display, 2x2 MIMO, and 802.11a/g/n/ac
Operation Frequency Range	2.4-2.4835 GHz; 5.150-5.250 GHz; 5.725-5.850 GHz
Transmitter Power (EIRP)	2.4 GHz FCC: ≤21.5 dBm; CE/SRRC: ≤18.5 dBm; MIC: ≤20.5 dBm 5.2 GHz FCC/CE/SRRC/MIC: ≤19 dBm 5.8 GHz FCC/SRRC: ≤21 dBm; CE: ≤13 dBm
Bluetooth	
Protocol	Bluetooth 4.2
Operation Frequency Range	2.4-2.4835 GHz
Transmitter Power (EIRP)	≤4 dBm
* Battery Charger	
Voltage	17.6±0.1 V
Rated Power	60 W
* Intelligent Flight Battery	
Capacity	3850 mAh
Voltage	17.6 V (max) 15.4 V (typical)
Battery Type	LiPo 4S
Energy	59.29 Wh
Net Weight	Approx. 297 g
Charging Temperature Range	41° to 104° F (5° to 40° C)
Max Charging Power	80 W
Auto Heating Temperature Range	-4° to 43° F (-20° to 6° C)
Auto Heating Time	600 s (max)
Auto Heating Power	35 W (max)
* 24W USB Charger	
Input	100-240 V~50/60 Hz, Max. 0.8 A
Output	3.6-8 V = 3.0 A / 12 V = 2.0 A

※ Local regulations in some countries prohibit the use of the 5.8 GHz and 5.2 GHz frequencies and in some regions the 5.2 GHz frequency band is only allowed for indoor use.

For more information, read the User Manual:
www.dji.com/mavic-2-enterprise

※ This content is subject to change without prior notice.

MAVIC is a trademark of DJI.
Copyright © 2020 DJI All Rights Reserved.

Printed in China.

认识 Mavic 2 行业双光版

MAVIC™ 2 行业双光版飞行器配备先进的全方位视觉系统及红外传感系统*，可在室内外稳定悬停、飞行，具备自动返航以及障碍物感知功能。飞行器内置 DJI AirSense 可检测周围航空器情况，支持密码保护以保障设备及数据安全，并且可搭载指定配件以适应不同应用场景。双光版飞行器配备高精度增稳云台，搭载 FLIR 长波红外非制冷热成像相机与可见光相机，可同时拍摄热成像与可见光影像，并支持两者融合显示。最大飞行速度为 72 km/h，最长飞行时间** 约为 31 分钟。

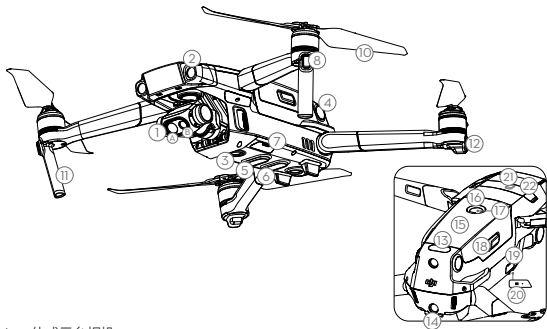

1. 一体式云台相机

- A. 可见光相机
- B. 红外相机

2. 前视视觉系统

3. 下视视觉系统

4. 侧视视觉系统

5. 底部红外传感系统

6. 下视补光灯

7. 相机 Micro SD 卡槽

8. 飞行器机头指示灯

9. 电机

10. 螺旋桨

11. 天线

12. 飞行器状态指示灯

13. 顶部红外传感系统

14. 后视视觉系统

15. 智能飞行电池

16. 电池电量指示灯

17. 电池开关

18. 电池卡扣

19. 调参 / 数据接口 (USB-C)

20. 对频按键 / 对频指示灯

21. 扩展接口 (可连接配件)

22. 扩展接口保护盖

* 视觉系统及红外传感系统有使用环境与条件要求，请阅读《免责声明与安全概要》及《用户手册》了解安全注意事项，并在 DJI™ 官方网站观看教学视频以正确使用相关功能。

<http://www.dji.com/mavic-2-enterprise>

** 最长飞行时间为无风环境时以 25 km/h 匀速飞行时测得。

DJI 带屏遥控器

DJI 带屏遥控器采用 OCUSSYNC™ 2.0 高清图传技术，配合完备的功能按键可在最大 10 千米* 通信距离内完成飞行器与相机的操作与设置。遥控器内置 5.5 英寸高亮触摸屏，具备蓝牙及卫星定位等功能，并支持通过 Wi-Fi 连接至互联网。可拆卸摇杆设计更便于遥控器收纳。最长工作时间* 约为 2.5 小时。

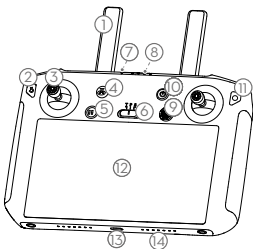

1. 天线
2. 退回按键 / 系统功能按键
3. 摇杆
4. 智能返航按键
5. 急停按键
6. 飞行模式切换开关
7. 状态指示灯
8. 电量指示灯
9. 五维按键
10. 电源按键
11. 确认按键 / 自定义功能按键 C3
12. 触摸显示屏
13. USB-C 接口
14. 麦克风



15. 云台俯仰控制拨轮
16. 录影按键
17. HDMI 接口
18. MicroSD 卡槽
19. USB-A 接口
20. 对焦 / 拍照按键
21. 光圈 / 快门调节拨轮

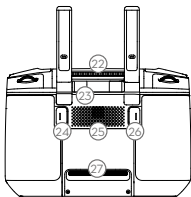

22. 出风口
23. 摇杆收纳槽
24. 自定义功能按键 C2
25. 扬声器
26. 自定义功能按键 C1
27. 入风口

* 在开阔无遮挡、无电磁干扰的环境飞行，并且飞行高度为 120 米左右，在 FCC 标准下遥控器可以达到最大通信距离。最长可工作时间为实验环境下测得，仅供参考。

1. 观看教学视频

访问 DJI 官方网站 www.dji.com/mavic-2-enterprise/info#video 观看教学视频。



教学视频

2. 准备飞行器

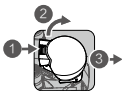

移除云台保护罩



展开前机臂



展开后机臂

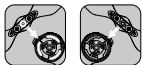

白色标记 无标记

匹配标记安装螺旋桨



嵌入桨座按压到底，沿锁紧方向旋转直至弹起锁定



展开状态

 请确保按顺序展开机臂，在机臂与桨叶全部展开之后再开启飞行器。

3. 充电

首次使用需给智能飞行电池充满电以激活电池。

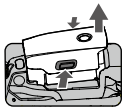

取出智能飞行电池

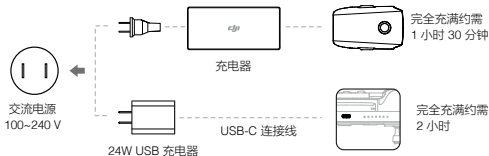

请使用官方 24W USB 充电器对带屏遥控器进行充电。如不使用官方充电器，推荐使用符合 FCC/CE 标准，规格为 12V/2A 的 USB 充电器。

• 检查电量与开启 / 关闭

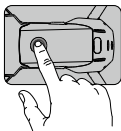

短按一次检查电量。
短按一次，再长按 2 秒可开启、
关闭飞行器。

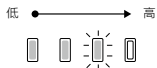
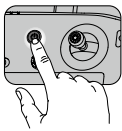

短按一次电源按钮查看电量。
短按一次电源按钮，再长按 2 秒以开启、
关闭遥控器。



安装电池至飞行器后并开启电源后，一旦电池温度低于 6°C，电池将开启自动加热功能，保持电池温度在 8-10°C 之间。详细内容请参考用户手册。

4. 准备遥控器



向上抬起天线



取出摇杆



安装摇杆

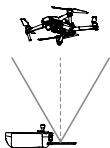
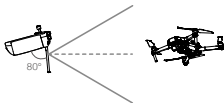
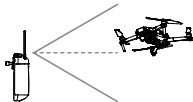

获取最佳通信范围，遥控器与飞行器的相对位置如图所示，当天线与遥控器背面呈 80° 或 180° 夹角时，且天线平面正对飞行器，可让遥控器与飞行器的信号质量达到最佳状态。

此图示为使用遥控器远距离操控飞行器下的建议角度。



- 注意将摇杆拧紧，确保安装到位。
- 实际操作中，DJI Pilot App 在图传信号不佳时将会进行提示，请根据提示调整天线位置，确保飞行器处于最佳通信范围。

5. 准备飞行



开启遥控器



开启飞行器



运行 DJI Pilot App



全新的设备需激活才能使用。请先开启遥控器并根据提示完成激活，再使用 DJI Pilot App 激活飞行器。激活时请确保设备可以接入互联网。



可在 DJI Pilot App 中对飞行器设置安全密码以保证飞行器的使用安全。

6. 飞行

起飞前请务必等待 DJI Pilot App 相机界面显示“起飞准备完毕”。

起飞准备完毕 (GPS)

- 手动起飞 / 降落
- 摇杆动作：
- 电机启动 / 停止



起飞：
缓慢向上推动油门杆（默认左摇杆）飞行器起飞。



降落：
向下拉动油门杆至飞行器落地，在最低位置保持 2 秒，电机停止。



飞行过程中若遇到紧急情况，可执行摇杆动作停止电机以减少伤害，电机紧急停机方式可在 DJI Pilot App 中进行设置。

• 遥控器操作

遥控器出厂默认操控方式为“美国手”。左摇杆控制飞行高度与方向，右摇杆控制飞行器的前进、后退以及左右飞行方向。云台俯仰控制拨轮可控制相机的俯仰拍摄角度。

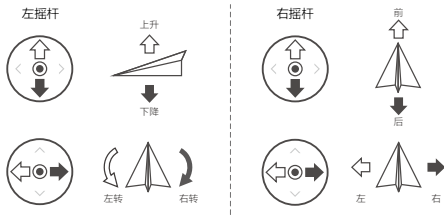

- 请预先在 DJI Pilot App 设置合适的自动返航高度。
- 飞行过程中遇到需要紧急刹车的情况，请按急停按键使飞行器悬停。

* 可扩展配件



夜航灯



探照灯



喊话器

7. 飞行安全



在开阔无遮挡
的环境中飞行

+



GPS信号良好

+



在目视范围内飞行

+



控制飞行高
度低于120米



飞行时请远离人群、树木、电线、高大建筑物、机场和信号发射塔等。无线电发射塔、高压线、变电站以及具有磁性的大块金属可能会对遥控信号及指南针产生干扰，威胁飞行安全。



下雨、大雾、下雪、雷电、大风（风速每秒10米及以上）等天气请勿飞行。



切勿接触旋转中的螺旋桨，
否则可能受到严重人身财产损害。



禁飞区

详情请访问以下网址：
<http://fllysafe.dji.com/no-fly>



禁飞区、飞行安全认识对于您、周围人群与环境的安全非常重要。
请务必仔细阅读《免责声明和安全概要》。

规格参数

• 飞行器

起飞重量	899 g
最大水平飞行速度	72 km/h (运动模式, 海平面附近无风环境)
最大起飞海拔高度	6000 m
工作环境温度	-10°C至 40°C
GNSS	GPS + GLONASS
工作频率	2.4-2.4835 GHz; 5.725-5.850 GHz
发射功率 (EIRP)	2.4 GHz FCC: ≤26 dBm; CE/MIC: ≤20 dBm; SRRC: ≤20 dBm 5.8 GHz FCC: ≤26 dBm; CE: ≤14 dBm; SRRC: ≤26 dBm
机载内存	24 GB

• 云台

可控转动范围	俯仰: -90° 至 +30°
--------	-----------------

• 红外相机

传感器	非制冷氧化钒微测辐射热计
镜头	视角: 57° (HFOV) 光圈: f/1.1 12 μm 8-14 μm
像元间距	12 μm
波长范围	8-14 μm
照片尺寸	640 × 480 (4:3); 640 × 360 (16:9)
照片拍摄模式	单张拍摄 多张连拍 (BURST): 3/5/7 张 定时拍摄: 2/3/5/7/10/15/20/30/60 s
录像分辨率	640 × 360 @8.7fps
测温精度	高增益模式: 最大 5% (典型值) 低增益模式: 最大 10% (典型值)
场景动态范围	高增益模式: -10° 至 +140° C 低增益模式: -10° 至 +400° C

图片格式	JPEG
视频格式	MP4, MOV (MPEG-4 AVC/H.264)

• 可见光相机

影像传感器	1/2.3 英寸 CMOS; 有效像素 1200 万
镜头	视角: 约 85° 35 mm 格式等效焦距: 24 mm 光圈: f/2.8 对焦点: 0.5 m 至无穷远
ISO 范围	视频: 100-12800 (自动) 照片: 100-1600 (自动)
最大照片尺寸	4056 × 3040 (4:3); 4056 × 2280 (16:9)
照片拍摄模式	单张拍摄 多张连拍 (BURST): 3/5/7 张 定时拍摄: 2/3/5/7/10/15/20/30/60 s
录像分辨率	4K Ultra HD: 3840 × 2160 30p 2.7K: 2688 × 1512 30p FHD: 1920 × 1080 30p
视频最大码流	100 Mbps
图片格式	JPEG
视频格式	MP4, MOV (MPEG-4 AVC/H.264)

• 遥控器	
电池	5000mAh @ 7.2V
工作环境温度	-20°C至 40°C
存储空间	ROM 16GB + 可扩展 (microSD 卡)
Ocusync 2.0	
工作频率	2.4-2.4835 GHz; 5.725-5.850 GHz
最大信号有效距离	FCC: 10 km; CE/MIC: 6 km; SRRC: 6 km
发射功率 (平均 EIRP)	2.4 GHz FCC: ≤25.5 dBm; CE/MIC: ≤18.5 dBm; SRRC: ≤19 dBm 5.8 GHz FCC: ≤25.5 dBm; CE: ≤12.5 dBm; SRRC: ≤18.5 dBm
Wi-Fi	
协议	WiFi Direct, Wi-Fi Display, 802.11a/g/n/ac 支持 2 × 2 MIMO Wi-Fi
工作频率	2.4-2.4835 GHz; 5.150-5.250 GHz; 5.725-5.850 GHz
发射功率 (平均 EIRP)	2.4 GHz FCC: ≤21.5 dBm; CE/SRRC: ≤18.5 dBm; MIC: ≤20.5 dBm 5.2 GHz FCC/CE/SRRC/MIC: ≤19 dBm 5.8 GHz FCC/SRRC: ≤21 dBm; CE: ≤13 dBm
蓝 牙	
协议	蓝牙 4.2
工作频率	2.4-2.4835 GHz
发射功率 (平均 EIRP)	≤4 dBm
• 充电器	
电压	17.6 ± 0.1 V
额定功率	60 W
• 智能飞行电池	
容量	3850 mAh
电压	17.6 V (满充电压) 15.4 V (典型电压)
电池类型	LiPo 4S
能量	59.29 Wh
电池整体重量	约 297 g
充电环境温度	5°C 至 40°C
最大充电功率	80 W
自加热环境温度	-20°C至 6°C
自加热时间	600 s (最大)
自加热功率	35 W (最大)
• 24W USB 充电器	
输入	100-240 V~50/60 Hz, 最大 0.8 A
输出	3.6-8 V ∓ 3.0 A / 12 V ∓ 2.0 A

※ 部分地区不支持 5.2GHz 和 5.8GHz 频段, 以及部分地区 5.2GHz 频段仅限室内使用, 详情请参考当地法律法规。

了解产品详细信息, 请访问以下网址下载《用户手册》

www.dji.com/mavic-2-enterprise

※ 内容如有更新, 恕不另行通知。

MAVIC 是大疆创新的商标。

Copyright © 2020 大疆创新 版权所有

Printed in China.

認識 Mavic 2 Enterprise

MAVIC™ 2 行業雙光版飛行器配備先進的全方位視覺系統及紅外線感應系統*，可在室內外穩定懸停、飛行，具備自動返航以及障礙物感應功能。航拍機內建 DJI AirSense，可偵測周圍航拍機情況，支援密碼保護可保障裝置及資料安全，並且可搭載指定配件以滿足不同應用場景需求。Mavic 2 Enterprise 配備高度精密增穩雲台和等效 24-48mm 的二倍光學變焦鏡頭，可穩定拍攝 4K 超高畫質影片與 1200 萬像素照片，最高可支援 FHD 6 倍變焦。最大飛行速度為 72 km/h，最長飛行時間** 約為 31 分鐘。

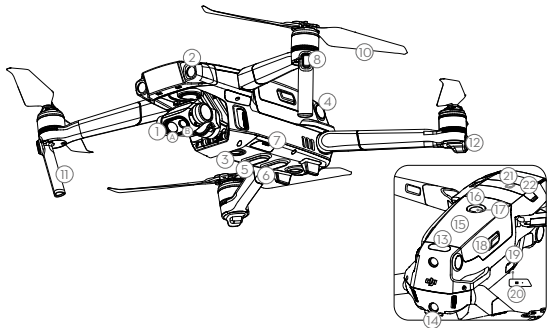

- | | |
|--------------------|------------------------|
| 1. 整合式雲台相機 | 8. 航拍機機頭指示燈 |
| A. 可見光相機 | 9. 馬達 |
| B. 紅外線相機 | 10. 螺旋槳 |
| 2. 前視視覺系統 | 11. 天線 |
| 3. 下視視覺系統 | 12. 航拍機狀態指示燈 |
| 4. 側視視覺系統 | 13. 頂部紅外線傳感系統 |
| 5. 底部紅外線傳感系統 | 14. 後視視覺系統 |
| 6. 補光燈 | 15. 智能飛行電池 |
| 7. 相機 Micro SD 卡插槽 | 16. 電池電量指示燈 |
| | 17. 電池開關 |
| | 18. 電池卡扣 |
| | 19. 調參 / 數據連接埠 (USB-C) |
| | 20. 配對按鈕 / 配對指示燈 |
| | 21. 擴充接頭 (可連接配件) |
| | 22. 擴充接頭保護蓋 |

* 視視覺系統及紅外線傳感系統有使用環境與條件方面的要求，請閱讀《免責聲明與安全總覽》及《使用者手冊》以了解安全注意事項。另請上 DJI™ 官方網站觀看教學影片，以便正確使用相關功能。

<http://www.dji.com/mavic-2-enterprise>

** 最長飛行時間是在無風環境下，以 25 km/h 等速飛行測得。

DJI 附螢幕遙控器

DJI 附螢幕遙控器採用 OCUSSYNC™ 2.0 高解析圖像傳遞技術，配合完備的功能按鍵，可在最大 10 公里* 通訊距離內完成空拍機與相機的操作與設置。遙控器內置 5.5 英寸高亮度觸控螢幕，具備藍牙及衛星定位等功能，並支援 Wi-Fi 連線至網際網路。可拆卸搖桿設計更有利於遙控器收納。最長運轉時間* 約為 2.5 小時。

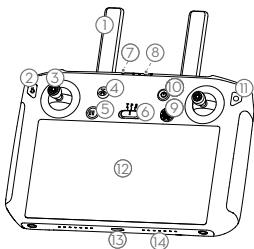

1. 天線
2. 退回按鍵 / 系統功能按鍵
3. 搖桿
4. 智慧返航按鈕
5. 急停按鈕
6. 飛行模式切換開關
7. 狀態指示燈
8. 電量指示燈
9. 五維按鈕
10. 電源按鈕
11. 確認按鍵 / 自訂功能按鍵 C3
12. 觸控螢幕
13. USB-C 連接埠
14. 麥克風
15. 雲台俯仰控制轉盤



16. 錄影按鈕
17. HDMI 連接埠
18. MicroSD 卡插槽
19. USB-A 連接埠
20. 對焦 / 拍照按鈕
21. 光圈 / 快門調節撥輪

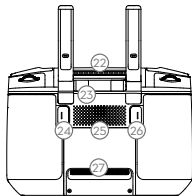

22. 出風口
23. 搖桿收納槽
24. 自訂功能按鍵 C2
25. 喇叭
26. 自訂功能按鍵 C1
27. 入風口

* 若在開闊無遮擋、無電磁干擾的環境下，於高度 120 公尺左右飛行時，遙控器即可依據 FCC 標準達到最大通訊距離。最長運作時間為實驗環境下測得，僅供參考。

1. 觀看教學影片

前往 DJI 官方網站 www.dji.com/mavic-2-enterprise/info#video 觀看教學影片。



教學影片

2. 準備航拍機



移除雲台保護罩



展開前機臂



展開後機臂

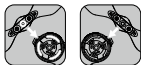

白色標記 無標記

匹配标记安装螺旋桨



嵌入槳座並按壓到底，沿鎖緊方向旋轉直到彈起鎖定



展開狀態

 請確保按順序展開機臂，在機臂與槳葉全部展開之後再開啟航拍機。

3. 充電

首次使用時，必須為智能飛行電池充電以啟動電池。

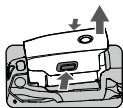

取出智能飛行電池

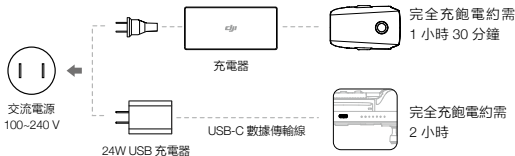

使用官方 24W USB 充電器連接附屬遙控器進行充電。如不使用官方充電器，推薦使用符合 FCC/CE 標準，規格為 12V/2A 的 USB 充電器。

• 檢查電量與開啓 / 關閉

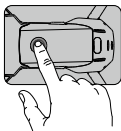

短按一次檢查電量。
短按一次，再長按 2 秒可開啟、
關閉航拍機。

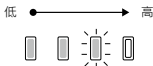
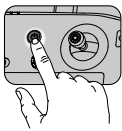

短按一次電源按鈕以查看電量。
短按一次電源按鈕，再長按 2 秒以開啟、
關閉遙控器。



在航拍機上安裝電池並開啟電源後，一旦電池溫度低於 6°C，電池將開啟自動加熱功能，讓電池溫度保持在 8 - 10°C 之間。詳細內容請參閱使用者手冊。

4. 準備遙控器



向上抬起天線



取出搖桿



安裝搖桿

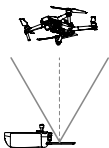
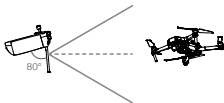
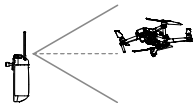

取得最佳通訊範圍，遙控器與空拍機的相對位置如圖所示，當天線與遙控器背面呈 80° 或 180° 夾角時，且天線平面正對空拍機，可讓遙控器與空拍機的訊號品質達到最佳狀態。

此圖示為使用遙控器遠距離操控空拍機下的建議角度。



- 注意將搖桿鎖緊，以確保安裝到位。
- 實際操作中，DJI Pilot App 在圖傳訊號不佳時將會進行提示，請根據提示調整天線位置，確保空拍機處於最佳通訊範圍。

5. 準備飛行



開啟遙控器



開啟航拍機



執行 DJI Pilot App
應用程式



Internet

全新的設備需啟動才能使用。請先開啓遙控器並根據提示完成啟動，再使用 DJI Pilot App 啟動空拍機。啟動時請確認設備已連線至網際網路。



可在 DJI Pilot 應用程式中設定航拍機安全密碼以確保航拍機的使用安全。

6. 飛行

起飛前，請務必等待 DJI Pilot 應用程式相機介面顯示「起飛準備完畢」(起飞准备完毕)。

起飛準備完畢 (GPS)

• 手動起飛 / 降落

綜合控制桿指令：

馬達啟動 / 停止



起飛：
緩慢向上推動油門桿（預設左搖桿）使航拍機起飛。



降落：
向下拉動油門桿至航拍機落地，在最低位置保持 2 秒，馬達接著停止。



飛行過程中如遇緊急情況，可執行掰杆動作停止電機以減少損傷，可在 DJI Pilot App 中設定電機緊急停機方式。

遙控器操作

遙控器出廠預設操控方式為「美國手」。左搖桿控制飛行高度與方向，右搖桿控制航拍機的前進、後退以及左右飛行方向。雲台俯仰控制轉盤可控制相機的俯仰拍攝角度。

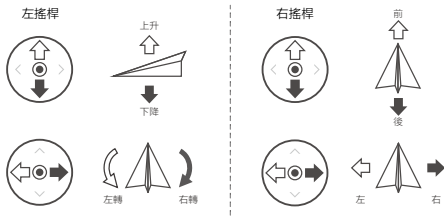

- 請預先在 DJI Pilot App 設置合適的自動返航高度。
- 飛行過程中遇到需要緊急制動的情況，請按急停按鈕使飛行器懸停。

* 擴充配件



夜航燈



探照燈



擴音器

7. 飛行安全



在開闊無遮蔽的環境中飛行

+



GPS 訊號良好

+



在視線範圍內飛行

+



將飛行高度控制在 120 公尺以下



飛行時請遠離人群、樹木、電線、高大建築物、機場和訊號發射塔等。無線電發射塔、高壓線、變電站及具有磁性的大型金屬物體均可能對遙控訊號及指南針產生干擾，進而威脅飛行安全。



請勿在下雨、起大霧、下雪、打雷閃電、大風 (風速每秒 10 公尺以上) 等天氣下飛行。



請遠離旋轉中的螺旋槳，否則可能會嚴重危及人身及財產安全。



禁航區

詳情請參閱以下網站：
<http://fllysafe.dji.com/no-fly>



了解禁飛區及飛行安全知識，對於您、周圍人群與環境的安全非常重要。請務必詳讀《免責聲明與安全總覽》。

規格

• 航拍機

起飛重量	899 g
最大水平飛行速度	72 km/h (運動模式, 海平面附近無風環境)
最大起飛海拔高度	6000 m
操作溫度	-20°C 至 40°C
GNSS	GPS + GLONASS
操作頻率	2.4-2.4835 GHz; 5.725-5.850 GHz
發射功率 (EIRP)	2.4 GHz FCC: ≤26 dBm; CE/MIC: ≤20 dBm; SRRC: ≤20 dBm 5.8 GHz FCC: ≤26 dBm; CE: ≤14 dBm; SRRC: ≤26 dBm
機載儲存容量	24 GB

• 雲台

可操控轉動範圍	俯仰: -90° 至 +30°
---------	-----------------

• 紅外線相機

感應器	非制冷氧化钒微測輻射熱計
鏡頭	視角: 57° (HFOV) 光圈: f/1.1
像素間距	12 μm
波長範圍	8-14 μm
照片尺寸	640 × 480 (4:3); 640 × 360 (16:9)
照片拍攝模式	單張拍攝 多張連拍 (高速): 3/5/7 張 定時拍攝: 2/3/5/7/10/15/20/30/60 秒

錄影解析度	640 × 360 @8.7fps
測溫精確度	高增益模式: 最大 5% (標準值) 低增益模式: 最大 10% (標準值)
場景動態範圍	高增益模式: -10° 至 +140° C 低增益模式: -10° 至 +400° C

圖片格式	JPEG
影片格式	MP4, MOV (MPEG-4 AVC/H.264)

• 可見光相機

影像感測器	1/2.3 英寸 CMOS; 有效像素 1200 萬
鏡頭	視角: 約 85° 35 mm 格式等效焦距: 24 mm 光圈: f/2.8 對焦點: 0.5 m 至無窮遠

ISO 範圍	影片: 100-12800 (自動) 照片: 100-1600 (自動)
--------	---

最大照片尺寸	4056 × 3040 (4:3); 4056 × 2280 (16:9)
照片拍攝模式	單張拍攝 多張連拍 (高速): 3/5/7 張 定時拍攝: 2/3/5/7/10/15/20/30/60 秒

錄影解析度	4K Ultra HD: 3840 × 2160 30p 2.7K: 2688 × 1512 30p FHD: 1920 × 1080 30p
-------	---

影片最大資料傳輸率	100 Mbps
圖片格式	JPEG

影片格式	MP4、MOV (MPEG-4 AVC/H.264)
• 遙控器	
電池	5000mAh @ 7.2V
操作溫度	-20°C 至 40°C
儲存空間	ROM 16GB + 可擴充 (microSD 卡)
Ocusync 2.0	
運轉頻率	2.4-2.4835 GHz; 5.725-5.850 GHz
最大訊號有效距離	FCC: 10 km; CE/MIC: 6 km; SRRC: 6 km
發射功率 (平均 EIRP)	2.4 GHz FCC: ≤25.5 dBm; CE/MIC: ≤18.5 dBm; SRRC: ≤19 dBm 5.8 GHz FCC: ≤25.5 dBm; CE: ≤12.5 dBm; SRRC: ≤18.5 dBm
Wi-Fi	
協議	WiFi Direct, Wi-Fi Display, 802.11a/g/n/ac, 支援 2 × 2 MIMO Wi-Fi
運轉頻率	2.4-2.4835 GHz; 5.150-5.250 GHz; 5.725-5.850 GHz
發射功率 (平均 EIRP)	2.4 GHz FCC: ≤21.5 dBm; CE/SRRC: ≤18.5 dBm; MIC: ≤20.5 dBm 5.2 GHz FCC/CE/SRRC/MIC: ≤19 dBm 5.8 GHz FCC/SRRC: ≤21 dBm; CE: ≤13 dBm
藍牙	
協議	藍牙 4.2
運轉頻率	2.4-2.4835 GHz
發射功率 (平均 EIRP)	≤4 dBm
• 充電器	
電壓	17.6 ± 0.1 V
額定功率	60 W
• 智能飛行電池	
容量	3850 mAh
電壓	17.6 V (滿充電壓); 15.4 V (一般電壓)
電池類型	LiPo 4S
能量	59.29 Wh
電池整體重量	約 297 g
充電環境溫度	5°C 至 40°C
最大充電功率	80 W
自動加熱環境溫度	-20°C 至 6°C
自動加熱時間	600 s (最大)
自動加熱功率	35 W (最大)
• 24W USB 充電器	
輸入	100-240 V~50/60 Hz, 最大 0.8 A
輸出	3.6-8 V = 3.0 A / 12 V = 2.0 A

※ 部分地區不支援 5.2GHz 和 5.8GHz 頻段，以及部分地區 5.2GHz 頻段僅限室內使用，詳情請參考當地法律法規。

要了解產品詳細資訊，請造訪以下網址下載《使用者手冊》

www.dji.com/mavic-2-enterprise

※ 內容如有更新，恕不另行通知。

MAVIC 是大疆創新的商標。

Copyright © 2020 大疆創新 版權所有

Printed in China.

機体

DJI™ MAVIC™ 2 Enterprise Dual は、全方向性ビジョンシステムおよび赤外線検知システム*を備え、FLIR 社製遠赤外線サーマル（熱画像）カメラと視覚カメラを併せ持つ完全な安定性を実現する 3 軸ジンバルカメラを搭載し、赤外線画像および視覚画像の両方を同時に提供します。障害物検知など、DJI の代表的な技術を用いて、複雑な撮影シーンも簡単に撮影できます。内蔵型の AirSense といった追加機能により、ユーザーは周囲の空域を把握することができます。また、パスワード保護により、機体への安全なアクセスを確保し、データを保護することができます。Mavic 2 Enterprise には、M2E スポットライト / M2E ピーコン / M2E スピーカーなどの取り付けられるモジュラーアクセサリも用意されています。Mavic 2 Enterprise の最大飛行速度は 72km/h、最大飛行時間**は 31 分です。

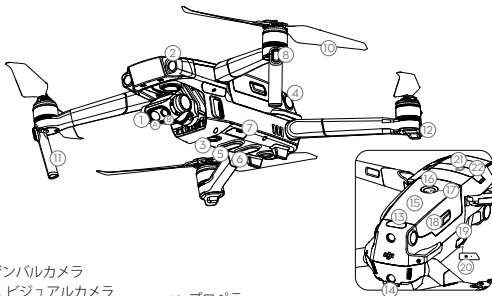

1. ジンバルカメラ

- A. ビジュアルカメラ
- B. サーマルカメラ

2. 前方ビジョンシステム

3. 下方ビジョンシステム

4. 側面ビジョンシステム

5. 下方赤外線検知システム

6. 底部補助ライト

7. microSD カード用スロット

8. フロント LED

9. モーター

10. プロペラ

11. アンテナ

12. 機体ステータスインジケータ

13. 上方赤外線検知システム

14. 後方ビジョンシステム

15. インテリジェント・フライト・バッテリー

16. バッテリー残量 LED

17. 電源ボタン

18. バッテリーバックル

19. USB-C ポート

20. リンクボタン / リンクステータスインジケータ

21. 拡張ポート（アクセサリ接続用）

22. 拡張ポートカバー

* ビジョンシステムおよび赤外線検知システムは、周辺環境の条件の影響を受けます。詳細に関しては、免責事項と安全に関するガイドライン / ユーザーマニュアルをお読みになり、公式 DJI ウェブサイトのチュートリアルビデオをご覧ください。 <http://www.dji.com/mavic-2-enterprise>

** 最長飛行時間は無風状態で、定速 25km/h でテストしたものです。この値は参考値です。

DJI スマート送信機

DJI スマート送信機は、DJI の長距離伝送技術 OCUSYNC™ 2.0 を搭載する送信機で、最大伝送距離は 10 km（日本国内では 6 km）で、機体カメラからの HD ライブビューを実現します。DJI スマート送信機は、5.5 インチ高輝度スクリーンを内蔵しています。また、カスタム可能なボタンを備え、様々な機体とジンバル制御を実現します。さらに、Bluetooth や GNSS といった多機能性も装備。Wi-Fi によるインターネット接続にも対応しています。DJI スマート送信機の最大動作時間は 2.5 時間です*。

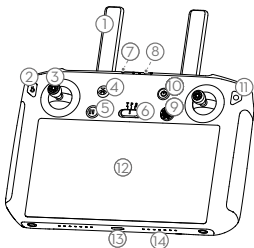

1. アンテナ
2. 戻るボタン/ファンクションボタン
3. スティック
4. RTH ボタン
5. フライト一時停止ボタン
6. フライトモードスイッチ
7. ステータス LED
8. バッテリー残量 LED
9. 5D ボタン
10. 電源ボタン
11. 確認ボタン/カスタムボタン C3
12. タッチスクリーン
13. USB-C ポート
14. マイク
15. ジンバルダイヤル



16. 録画ボタン
17. HDMI ポート
18. microSD カード用スロット
19. USB-A ポート
20. フォーカス/シャッターボタン
21. 絞り/シャッター調節ダイヤル

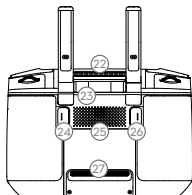

22. 通気口
23. スティック格納スロット
24. カスタムボタン C2
25. スピーカー
26. カスタムボタン C1
27. 吸気口

* DJI スマート送信機は、高度約 120m で広くて開けた電磁干渉のない場所で、最大伝送距離 (FOC) を実現します。最大稼働時間は、ラボ環境でテストされています。この値は参考値です。

1. チュートリアルビデオの視聴

チュートリアルビデオは、www.dji.com/mavic-2-enterprise/info#video からご覧ください。



チュートリアルビデオ

2. 機体の準備

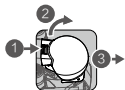

カメラからジンバルカパーを取り外します。



前方アームを展開します。



後方アームを展開します。

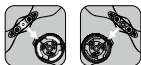

マークあり マークなし
プロペラをモーターに
合わせます。



プロペラを下に向かって強く押して、ロック方向へ回転させます。



展開状態



前方のアームとプロペラを展開してから、後方のアームとプロペラを展開します。
離陸前にすべてのアームとプロペラを展開しておく必要があります。

3. バッテリーの充電

初めて使用する場合は、付属の充電器を使用して、インテリジェント・フライト・バッテリーを完全に充電しておきます。

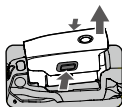

インテリジェント・フライト・
バッテリーの取り外し

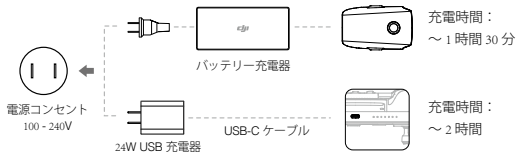

⚠ DJI スマート送信機を充電する場合、24W USB 充電器（純正品）を使用してください。標準の 24W USB 充電器がお手元がない場合、FCC/CE 認定の定格 12V/2A の USB 充電器のご使用を推奨します。

・バッテリー残量の確認と電源のオン/オフ

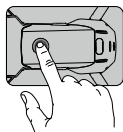

ボタンを 1 回押すと、バッテリー残量を
確認できます。
ボタンを押してから、次に長押しすると、
電源がオンまたはオフになります。

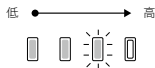
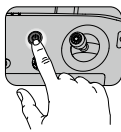

ボタンを 1 回押すと、液晶画面でバッテリ
ー残量を確認できます。
ボタンを 1 回押し、次に長押しすると、送
信機の電源がオンまたはオフになります。

⚠ バッテリーを機体に取り付け、電源を入れてください。バッテリー温度が 6℃以下になると、自動発熱機能により温度を 8～10℃に維持します。詳しくはユーザーマニュアルをご覧ください。

4. 送信機の準備



アンテナを持ち上げる



スティックを取り外す



回転させてスティック
を取り付ける

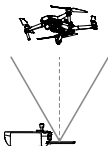
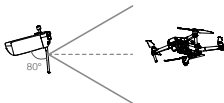
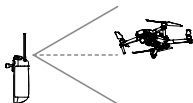

最適な伝送範囲は上図に示されています。アンテナが機体の方に向いていることを確認してください。アンテナとスマート送信機の背面との間の角度が 80° または 180° である場合、スマート送信機と機体との間の接続は最適な性能に到達できます。

上の図は、オペレータと機体が遠く離れている状況を示しています。



- コントロールスティックをしっかり取り付けてください。
- 実際の操作では、DJI Pilot アプリは伝送信号が弱いことを警告します。機体が最適な伝送範囲に戻るようアンテナを調整してください。

5. 離陸の準備



送信機の電源を入れる



機体の電源を入れる



DJI Pilot を起動する



インターネット

DJI アカウントを使用して、機体と DJI スマート送信機をアクティベーションします。アクティベーションにはインターネット接続が必要です。DJI Pilot で機体をアクティベーションする前に、DJI スマート送信機の電源を入れ、指示に従ってアクティベーションしてください。



安全なアクセスと内蔵データの保護を確実にするため、DJI Pilot アプリで機体のパスワードを設定してください。

6. 飛行

離陸する前に、DJI Pilot の機体ステータスバーに「Ready to Go」が表示されていることを確認してください。

Ready to Go (GPS)

・手動での離陸/着陸

コンビネーション・スティック・コマンドでモーター始動/停止



左スティックを
ゆっくり上に倒
して離陸



地面に着くまで、左スティックを（ゆっくりと）下に倒します。
数秒間そのまま保持してから、モーターを停止します。



飛行中のモーター停止は、人体や物体への損傷・負傷のリスクを低減させる目的で緊急時のみ行ってください。モーターの停止方法は、DJI Pilot で設定することができます。

送信機操作

デフォルトのフライトコントロールはモード2です。左スティックで機体の高度と進行方向、右スティックで前進、後退、右回転、左回転をコントロールします。ジンバルダイヤルでカメラのチルト操作をコントロールします。

左スティック



右スティック



- 離陸前に、必ず適切な Return-to-Home (RTH) 高度を設定してください。機体をホームポイントに戻す際は、コントロールスティックで誘導してください。
- 飛行中に緊急ブレーキをかけるときは、フライト一時停止ボタンを押します。

* モジュラーアクセサリー



M2E ビーコン



M2E スポットライト



M2E スピーカー

7. 安全なフライトのために



開けた場所での
飛行

+



強いGPS信号

+



視界の維持

+



120m未満の高度で
飛行



障害物、人混み、高電圧線、樹木、水域の近くで飛行させないでください。
電線や基地局などの強い電磁波域の周辺では、機体のコンパスが性能を発揮できないことがあるため、飛行させないでください。



雨、雪、霧、風速10m/s超などの悪天候時に機体を使用しないでください。



回転中のプロペラやモーターから
離れてください。



飛行禁止区域

詳細については、以下でご確認ください。
<http://www.dji.com/jp/flysafe/no-fly>



ご自身の安全と周りの人々の安全のため、基本的なフライトガイドラインを理解することが重要です。免責事項および安全に関するガイドラインを必ずお読みください。

仕様

•機体

重量	899 g
最大速度	無風、スポーツモードで 72 km/h
運用限界高度	6,000 m
動作環境温度	-10 ~ 40°C
GNSS	GPS + GLONASS
動作周波数	2.4 ~ 2.4835 GHz、5.725 ~ 5.850 GHz (日本国内では 2.4 ~ 2.4835 GHz のみ利用可)
送信機出力 (EIRP)	2.4 GHz FCC : 26 dBm 以下、CE/MIC : 20 dBm 以下、SRRC : 20 dBm 以下 5.8 GHz FCC : 26 dBm 以下、CE : 14 dBm 以下、SRRC : 26 dBm 以下
内部ストレージ	24 GB

•ジンバル

操作可能範囲	ピッチ : -90° ~ +30°
--------	-------------------

•サーマルカメラ

センサー	非冷却 VOx マイクロボロメーター
レンジ	HFOV : 57° 絞り : F1.1
画素ピッチ	12 μm
スペクトル帯	8 ~ 14 μm
画像サイズ	640 × 480 (4:3)、640 × 360 (16:9)
静止画撮影モード	シングルショット バーストショット : 3/5/7 枚 間隔 (2/3/5/7/10/15/20/30/60 秒)

動画撮影モード	640 × 360 @8.7fps
精度	高利得 : 最大 ± 5% (標準) 低利得 : 最大 ± 10% (標準)
シーン範囲	高利得 : -10 ~ +140° C 低利得 : -10 ~ +400° C
写真	JPEG
動画	MP4、MOV (MPEG-4 AVC/H.264)

•視覚カメラ

センサー	1/2.3 インチ CMOS、有効画素数 : 12M
レンジ	FOV : 約 85° 35mm 版換算 : 24mm 絞り : F2.8 フォーカス : 0.5m ~ ∞
ISO レンジ	動画 : 100 ~ 12800 (オート) 写真 : 100 ~ 1600 (オート)
最大静止画サイズ	4056 × 3040 (4:3)、4056 × 2280 (16:9)
静止画撮影モード	シングルショット バーストショット : 3/5/7 枚 間隔 (2/3/5/7/10/15/20/30/60 秒)
動画撮影モード	4K Ultra HD : 3840 × 2160 30p 2.7K : 2688 × 1512 30p FHD : 1920 × 1080 30p

最大ビデオビットレート	100 Mbps
写真	JPEG

動画	MP4、MOV (MPEG-4 AVC/H.264)
• スマート送信機	
バッテリー	5000mAh @ 7.2V
動作環境温度	-20°C ~ 40°C
ストレージ容量	ROM 16GB + 拡張性 (microSD カード)
OcuSync 2.0	
動作周波数範囲	2.4 ~ 2.4835 GHz、5.725 ~ 5.850 GHz (日本国内では 2.4 ~ 2.4835 GHz のみ利用可)
最大伝送距離	FCC: 10 km、CE/MIC (日本): 6 km、SRRC: 6 km (障害物、電波干渉のない場合)
出力 (EIRP)	2.4GHz FCC: ≤ 25.5 dBm、CE/MIC (日本): ≤ 18.5 dBm、SRRC: ≤ 19 dBm 5.8GHz FCC: ≤ 25.5 dBm、CE: ≤ 12.5 dBm、SRRC: ≤ 18.5 dBm
Wi-Fi	
プロトコル	Wi-Fi ダイレクト、WiFi Display、2 × 2 MIMO、802.11a/g/n/ac
動作周波数範囲	2.4-2.4835 GHz、5.150-5.250 GHz
出力 (EIRP)	2.4GHz FCC: ≤ 21.5 dBm、CE/SRRC: ≤ 18.5 dBm、MIC (日本): ≤ 20.5 dBm 5.2GHz FCC/CE/SRRC/MIC (日本): ≤ 19 dBm
Bluetooth	
プロトコル	Bluetooth 4.2
動作周波数範囲	2.4 ~ 2.4835 GHz
出力 (EIRP)	≤ 4 dBm
• バッテリー充電器	
電圧	17.6 ± 0.1 V
定格出力	60 W
• インテリジェント・フライト・バッテリー	
容量	3850 mAh
電圧	17.6 V (最大) 15.4 V (標準)
バッテリータイプ	LiPo 4S
電力量	59.29 Wh
正味重量	約 297 g
充電温度範囲	5 ~ 40°C
最大充電電力	80 W
自動発熱温度範囲	-20°C ~ 6°C
自動発熱時間	600 秒 (最大)
自動発熱出力	35 W (最大)
• 24W USB 充電器	
入力	最大 100-240 V ~ 50/60 Hz 0.8 A
出力	3.6-8 V ≡ 3.0 A / 12 V ≡ 2.0 A

※ 国によっては、現地の規制で 5.2GHz の周波数帯の使用を禁止していますが、屋内の使用に限 5.2GHz の周波数帯域を使用できる地域もあります。)

詳細については、以下にあるユーザーマニュアルを参照してください。

www.dji.com/mavic-2-enterprise

※ このコンテンツは予告なく変更される場合があります。

MAVIC は DJI の商標です。

Copyright © 2020 DJI All Rights Reserved.

Printed in China.

기체

DJI™ MAVIC™ 2 Enterprise Dual은 전방위 비전 시스템 및 적외선 감지 시스템*을 사용하며 FLIR 장파 적외선 열화상 카메라와 시각 카메라를 갖춘 완전 안정화된 3축 짐벌 카메라를 통해 적외선 이미지와 시각 이미지를 동시에 제공합니다. 장애물 감지와 같은 DJI 시그니처 기술을 사용하면 비행하면서 복잡한 장면도 손쉽게 촬영할 수 있습니다. 내장된 AirSense와 같은 추가 기능으로 주변 공역에 무엇이 있는지 알 수 있습니다. 또한 비밀번호 보안은 기체에 안전하게 액세스할 수 있게 해 주고 데이터를 보호해줍니다. 매빅 2 Enterprise는 M2E 소프트웨어, M2E 비콘, M2E 스피커와 같은 장착 가능한 모듈식 액세서리가 있어 다양한 용도로 활용할 수 있습니다. Mavic 2 Enterprise는 72km/h(44.7mph)의 최대 비행 속도와 31분에 이르는 최대 비행 시간**을 자랑합니다.

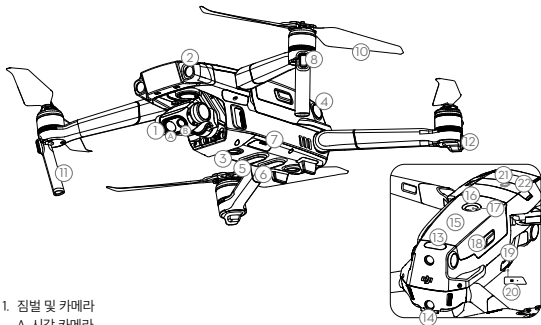

- | | |
|------------------|---------------------|
| 1. 짐벌 및 카메라 | |
| A. 시각 카메라 | |
| B. 열화상 카메라 | |
| 2. 전방 비전 시스템 | 9. 모터 |
| 3. 하향 비전 시스템 | 10. 프로펠러 |
| 4. 측방 비전 시스템 | 11. 안테나 |
| 5. 하향 적외선 감지 시스템 | 12. 기체 상태 표시기 |
| 6. 보조광 | 13. 상향 적외선 감지 시스템 |
| 7. microSD 카드 슬롯 | 14. 후방 비전 시스템 |
| 8. 전방 LED | 15. 인텔리전트 플라이트 배터리 |
| | 16. 배터리 잔량 LED |
| | 17. 전원 버튼 |
| | 18. 배터리 버클 |
| | 19. USB-C 포트 |
| | 20. 연동 버튼/연동 상태 표시기 |
| | 21. 확장 포트(액세서리 연결용) |
| | 22. 확장 포트 커버 |

* 비전 시스템 및 적외선 감지 시스템은 주변 환경의 영향을 받습니다. 고지사항 및 안전 가이드와 사용자 매뉴얼을 읽고, 공식 DJI 웹사이트에서 튜토리얼 영상을 시청하여 자세히 알아보십시오. <http://www.dji.com/mavic-2-enterprise>

** 최대 비행시간은 지속적인 25km/h(15.5mph)의 무풍 환경에서 테스트했습니다. 이 값은 참조용으로만 사용해야 합니다.

DJI 스마트 조종기

DJI 스마트 조종기는 DJI의 원거리 전송 기술인 OCUSSYNC™ 2.0으로 구축된 조종기로 10km의 최대 전송 거리를 갖추고 있으며 기체의 카메라로부터 실시간 HD 뷰를 제공합니다. 스마트 조종기에는 여러 기체 및 짐벌 제어 장치와 사용자 설정 버튼이 있으며 블루투스 및 GNSS와 같은 여러 기능을 갖춘 5.5인치 고휘도 스크린이 탑재되어 있습니다. Wi-Fi를 통한 인터넷 연결도 지원됩니다. 스마트 조종기의 최대 작동 시간은 2.5시간입니다*.

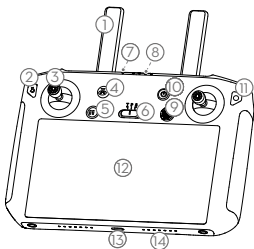

1. 안테나
2. 뒤로 버튼/기능 버튼
3. 스틱
4. RTH 버튼
5. 비행 일시 정지 버튼
6. 비행 모드 전환 스위치
7. 상태 LED
8. 배터리 잔량 LED
9. 5D 버튼
10. 전원 버튼
11. 확인 버튼/사용자 설정 버튼 C3
12. 터치 스크린
13. USB-C 포트
14. 마이크
15. 짐벌 다이얼

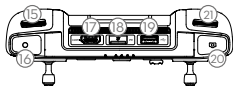

16. 녹화 버튼
17. HDMI 포트
18. MicroSD 카드 슬롯
19. USB-A 포트
20. 포커스/셔터 버튼
21. 조리개/셔터 조정 다이얼

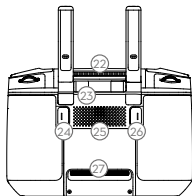

22. 통풍구
23. 스틱 보관 슬롯
24. 사용자 설정 버튼 C2
25. 스피커
26. 사용자 설정 버튼 C1
27. 흡기구

* 스마트 조종기는 트윈 야외 공간에서 자기장 간섭이 없을 때, 약 120m의 고도로 비행 시 최대 전송 거리(FCC)까지 제어가 가능합니다. 최대 지속 시간은 시험실 환경에서 테스트되었습니다. 이 값은 참조용량으로만 사용해야 합니다.

1. 튜토리얼 동영상 시청

www.dji.com/mavic-2-enterprise/info#video 에서 튜토리얼 영상을 시청하십시오.



튜토리얼 영상

2. 기체 준비

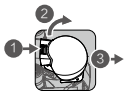

카메라에서 짐벌 커버를 분리합니다.



전방 암을 펴니다.



후방 암을 펴니다.

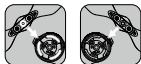

표시됨 표시되지 않음

모터에 프로펠러를 연결합니다.



프로펠러를 아래 방향으로 세게 누르고 잠금 방향으로 돌립니다.



편 상태

앞쪽 암과 프로펠러를 펴고 뒤쪽 암을 펴니다. 이륙 전에 모든 암과 프로펠러를 펴야 합니다.

3. 배터리 충전

처음 사용하기 전에 제공된 충전기를 사용하여 인텔리전트 플라이트 배터리를 완전히 충전합니다.

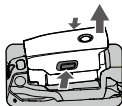

인텔리전트 플라이트 배터리 제거

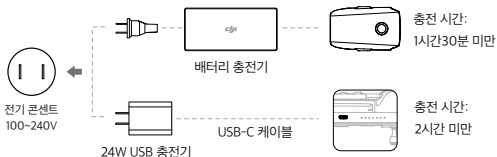

⚠ 스마트 조종기를 충전하려면 공식 24W USB 충전기를 사용하십시오. 표준 24W USB 충전기를 사용할 수 없는 경우 FCC/CE 인증 12V/2A USB 충전기를 사용하는 것을 권장합니다.

• 배터리 잔량 확인 및 전원 켜기/끄기

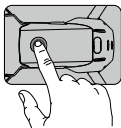

한 번 눌러 배터리 잔량을 확인합니다.
누른 다음 다시 길게 누르면 켜지거나 꺼집니다.

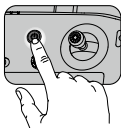

LCD 화면에서 한 번 눌러 배터리 수준을 확인합니다.

한 번 누른 다음 길게 누르면 조종기가 켜지거나 꺼집니다.

⚠ 기체에 배터리를 장착하고 전원을 켭니다. 배터리 온도가 6°C보다 낮아지면 자동으로 발열하여 8~10°C 사이의 온도를 유지합니다. 자세한 내용은 사용자 매뉴얼을 참조하십시오.

4. 조종기 준비

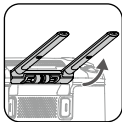

안테나를 들어 올리십시오



스틱을 분리하십시오



스틱을 돌려 부착하십시오

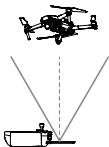
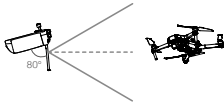
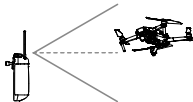

최적의 전송 범위는 위에 나와 있습니다. 안테나가 기체를 향하고 있는지 확인하십시오. 안테나와 스마트 조종기 후면의 각도가 80° 또는 180°인 경우 스마트 조종기와 기체 간의 연결이 최적의 성능에 도달할 수 있습니다.

위 그림은 운전자와 기체가 멀리 떨어져 있는 상태를 보여줍니다.



- 조종 스틱이 단단히 장착되었는지 확인하십시오.
- 실제 작동 시, DJI Pilot 앱이 송신 신호가 약하다는 경고를 보내면 기체가 최적의 전송 범위로 돌아오도록 안테나를 조정하십시오.

5. 이륙 준비



조종기 전원을 켭니다.



기체의 전원을 켭니다.



DJI Pilot를 실행합니다.



인터넷

DJI 계정을 사용하여 기체 및 스마트 조종기를 활성화합니다. 활성화하려면 인터넷 연결이 필요합니다. DJI Pilot에서 기체를 활성화하기 전에 스마트 조종기의 전원을 켜고 지시사항에 따라 활성화합니다.



DJI Pilot 앱에서 기체 비밀번호를 설정하여 안전하게 액세스하고 내부 데이터를 보호하십시오.

6. 비행

이륙하기 전에 DJI Pilot의 기체 상태 표시줄에 'Ready to Go'가 표시되어 있는지 확인합니다.

Ready to Go(GPS)

• 수동 이륙/착륙

스틱 조합 명령으로 모터를 시동/중지합니다.



또는



왼쪽 스틱을 위로 움직여(느리게) 이륙합니다.



지면에 닿을 때까지 왼쪽 스틱을 천천히 아래로 내립니다. 몇 초 동안 유지하면 모터를 중지됩니다.



손상 또는 부상의 위험을 줄일 수 있도록 긴급 상황에서만 비행 중에 모터를 중지하십시오. DJI Pilot 앱에서 모터 중지 방법을 설정할 수 있습니다.

• 조종기 조작

기본 비행 제어 방법은 모드 2입니다. 왼쪽 스틱은 기체의 고도 및 방향을 제어하고 오른쪽 스틱은 전진, 후진, 왼쪽 또는 오른쪽 이동을 제어합니다. 짐벌 다이얼은 카메라의 틸트를 제어합니다.

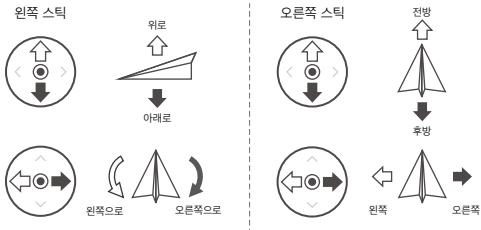

- 이륙하기 전에 항상 적절한 RTH 고도를 설정하십시오. 기체가 홈 포인트로 돌아올 때에는 조종 스틱으로 유도해야 합니다.
- 비행 도중 긴급 제동해야 할 경우 Flight Pause 버튼을 누르십시오.

* 모듈식 액세서리



M2E 비콘



M2E 스포트라이트



M2E 스피커

7. 비행 안전



시야가 확보된 넓은
지역에서 비행

+



강력한 GPS
신호

+



시야 유지

+



120m(400피트) 고도
미만에서 비행



장애물, 군중, 고압 전선, 나무 또는 수계 상공이나 근처에서 비행하지 마십시오.
전선 및 기지국에서 발생하는 강력한 전자기기는 내장 컴파스에 영향을 줄 수 있으므로 이런
지역 근처에서 비행하지 마십시오.



10m/초 이상

비, 눈, 안개, 10m/초(22mph) 이상의 강풍이 부는 악천후에서는 기체를 사용하지
마십시오.



회전하는 프로펠러와 모터에서 멀리 떨어져
계십시오.



비행 금지 구역

자세한 정보:
<http://flysafe.dji.com/no-fly>



본인과 주변의 안전을 위해 기본 비행 지침을 반드시 숙지해야 합니다. 고지 사항 및 안전 가이드를
잊지 말고 읽어보십시오.

사양

- 기체

무게

899g

최대 속도

바람이 없을 때 스포츠 모드에서 72km/h(44.7mph)

최대 실용 상승 한계 고도(해발)

6,000m(19,685피트)

작동 온도

-10°~40°C(14°~104°F)

GNSS

GPS + GLONASS

작동 주파수

2.4~2.4835GHz, 5.725~5.850GHz

송신기 전원

2.4GHz

(EIRP)

FCC: 26dBm 이하, CE/MIC: 20dBm 이하, SRRC: 20dBm 이하

5.8GHz

FCC: 26dBm 이하, CE: 14dBm 이하, SRRC: 26dBm 이하

24 GB

내부 저장 장치

- 집벌

제어 가능 범위

피치: -90°~+30°

- 열화상 카메라

센서

비냉각 VOx 마이크로볼로미터(Uncooled VOx Microbolometer)

렌즈

HFOV: 57°

조리개: f/1.1

픽셀 피치

12µm

스펙트럼 범위

8-14µm

이미지 크기

640×480(4:3); 640×360(16:9)

스틸 사진 모드

단일 촬영

연사 촬영: 3/5/7프레임

인터벌(2/3/5/7/10/15/20/30/60초)

동영상 녹화 모드

640×360 @8.7fps

정확도

높은 계인: 최대 ±5%(일반)

낮은 계인: 최대 ±10%(일반)

장면 범위

높은 계인: -10° ~ +140°C

낮은 계인: -10° ~ +400°C

사진

JPEG

동영상

MP4, MOV(MPEG-4 AVC/H.264)

- 시각 카메라

센서

1/2.3" CMOS, 유효 픽셀: 12M

렌즈

FOV: 약 85°

35mm 환산: 24mm

조리개: f/2.8

초점: 0.5m ~ ∞

ISO 범위

동영상: 100~12800(자동)

사진: 100~1600(자동)

최대 이미지 크기

4056×3040 (4:3), 4056×2280 (16:9)

스틸 사진 모드

단일 촬영

연사 촬영: 3/5/7프레임

인터벌(2/3/5/7/10/15/20/30/60초)

동영상 녹화 모드

4K UHD : 3840×2160 30p

2.7K : 2688×1512 30p

FHD : 1920×1080 30p

동영상 저장 비트 전송률

100Mbps

사진

JPEG

동영상

MP4 , MOV(MPEG-4 AVC/H.264)

- 스마트 조종기

배터리	5000mAh @ 7.2V
작동 온도 범위	-20° ~ 40° C
저장 용량	ROM 16GB+확장 장치 (microSD 카드)
OcuSync 2.0	
작동 주파수 범위	2.4 ~ 2.4835 GHz; 5.725 ~ 5.850 GHz
최대 전송 거리	FCC: 10 km; CE/MIC: 6 km; SRRC: 6 km (장애물과 간섭이 없을 시)
송신기 출력 (EIRP)	2.4 GHz FCC: ≤25.5 dBm; CE/MIC: ≤18.5 dBm; SRRC: ≤19 dBm 5.8 GHz FCC: ≤25.5 dBm; CE: ≤12.5 dBm; SRRC: ≤18.5 dBm

Wi-Fi

프로토콜	Wi-Fi Direct, WiFi Display, 2×2 MIMO, 802.11a/g/n/ac
작동 주파수 범위	2.4~2.4835 GHz; 5.150~5.250 GHz; 5.725~5.850 GHz
송신기 출력 (EIRP)	2.4 GHz FCC: ≤21.5 dBm; CE/SRRC: ≤18.5 dBm; MIC: ≤20.5 dBm 5.2 GHz FCC/CE/SRRC/MIC: ≤19 dBm 5.8 GHz FCC/SRRC: ≤21 dBm; CE: ≤13 dBm

블루투스

프로토콜	Bluetooth 4.2
작동 주파수 범위	2.4~2.4835 GHz
송신기 출력 (EIRP)	≤4 dBm

* 배터리 충전기

전압	17.6±0.1V
정격 출력	60W

* 인텔리전트 플라이트 배터리

용량	3850mAh
전압	17.6V(최대) 15.4V(일반)

배터리 유형	LiPo
에너지	59.29Wh
순중량	약 297g
충전 온도 범위	5°~40°C(41°~104°F)
최대 충전 전력	80W
자동 발열 온도 범위	-20° ~ 6° C
자동 발열 시간	600초 (최대)
자동 발열 전력	35 W (최대)

* 24W USB 충전기

입력	100-240 V~50/60 Hz, 최대 0.8 A
출력	3.6-8 V ≡ 3.0 A / 12 V ≡ 2.0 A

※ 일부 국가에서는 현지 규정에 따라 5.8GHz 및 5.2GHz 주파수 사용을 금지하고 일부 지역에서는 5.2GHz 주파수 대역을 실내에서만 사용할 수 있습니다.

자세한 내용은 사용자 매뉴얼을 확인하십시오.

www.dji.com/mavic-2-enterprise

※ 본 내용은 사전 고지 없이 변경될 수 있습니다.

MAVIC은 DJI의 상표입니다.

Copyright © 2020 DJI All Rights Reserved.

Printed in China.

Fluggerät

Die DJI™ MAVIC™ 2 Enterprise Dual ist mit Sicht- und Infrarotsensoren zur omnidirektionalen Hinderniserkennung* ausgestattet. Zudem verfügt sie über einen stabilisierten 3-Achsen Gimbal. Dank integrierter Sicht- und FLIR-Wärmebildkamera, kann gleichzeitig langwellige unsichtbare Infrarotstrahlung, als auch Bilder im sichtbaren Spektralbereich dargestellt werden. Bewährte, charakteristische Technologien von DJI, wie die Hinderniserkennung, unterstützen Sie beim Fliegen und Meistern komplexer Aufnahmen. Zusätzliche Funktionen wie das eingebaute DJI AirSense informieren Sie über den Luftraum in Ihrer Nähe. Der integrierte Passwortschutz schützt Ihre Daten auf der Drohne vor unbefugtem Zugriff. Die Mavic 2 Enterprise lässt sich darüber hinaus durch modulares Zubehör, wie dem M2E Scheinwerfer, dem M2E Positionslicht und dem M2E Lautsprecher für verschiedene Anwendungsszenarien erweitern. Die Mavic 2 Enterprise besteht durch eine maximale Fluggeschwindigkeit von 72 km/h und eine maximale Flugzeit** von 31 Minuten.

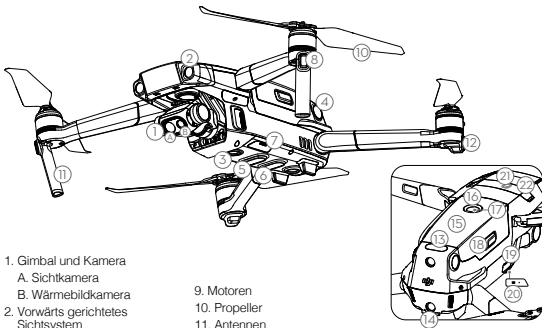

1. Gimbal und Kamera

- A. Sichtkamera
- B. Wärmebildkamera

2. Vorwärts gerichtetes Sichtsystem

3. Abwärts gerichtetes Sichtsystem

4. Seitliches Sichtsystem

5. Nach unten gerichtetes Infrarotsensorsystem

6. Hilfsbeleuchtung

7. Einschub für die Micro-SD-Karte

8. Vordere LEDs

9. Motoren

10. Propeller

11. Antennen

12. Statusanzeige des Fluggeräts

13. Nach oben gerichtete Infraroterkennung

14. Rückwärts gerichtetes Sichtsystem

15. Intelligent Flight Battery

16. Akkuladezustands-LED

17. Ein/Aus-Taste

18. Batterieklammern

19. USB-C-Anschluss

20. Koppeltaste/Kopplungsstatus-LED

21. Erweiterungssteckplatz (Zur Anbindung von Zubehör)

22. Abdeckung des Erweiterungssteckplatzes

* Die Sicht- und Infrarotsensorsysteme reagieren empfindlich auf die Umgebungsbedingungen. Lesen Sie zu Ihrer Information die Bedienungsanleitung, die Sicherheitsrichtlinien und Ausschlüsse und sehen Sie sich unsere Tutorial-Videos auf der offiziellen DJI Webseite an. <http://www.dji.com/mavic-2-enterprise>

** Die maximale Flugzeit wurde ohne Wind und bei einer konstanten Geschwindigkeit von 25 km/h getestet. Dieser Wert dient nur als Referenz.

DJI Smart-Fernsteuerung

Die DJI Smart-Fernsteuerung ist mit der Übertragungstechnologie OCUSSYNC™ 2.0 ausgestattet, diese ermöglicht eine maximale Reichweite von 10 Kilometern und eine HD-Liveübertragung von der Hauptkamera. Sie bietet eine Vielzahl an Steuerungsmöglichkeiten für das Fluggerät und den Gimbal, mehrere frei belegbare Tasten, einen besonders hellen Bildschirm wie auch weitere Funktionalitäten wie Bluetooth oder GNSS. Die Verbindung zum Internet kann über Wi-Fi hergestellt werden. Die maximale Betriebszeit liegt bei 2,5 Stunden*.

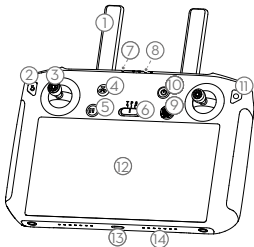

1. Antennen
2. Zurück-Taste / Funktionstaste
3. Steuerknüppel
4. Rückkehrtaste
5. Taste zum Pausieren des Fluges
6. Flugmodusschalter
7. Status-LED
8. Akkuladezustands-LED
9. 5D-Taste
10. Ein/Aus-Taste
11. Bestätigen-Taste / Anpassbare Taste C3
12. Touchscreen
13. USB-C-Anschluss
14. Mikrofon



16. Videoaufnahme-taste
17. HDMI-Anschluss
18. Einschub für die Micro-SD-Karte
19. USB-A-Anschluss
20. Fokus-/Fototaste
21. Einstellrädchen für Blende/Verschlusszeit

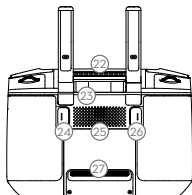

22. Entlüftungsschlitze
23. Aufbewahrungsfach für Steuerknüppel
24. Taste C2 (frei belegbar)
25. Lautsprecher
26. Taste C1 (frei belegbar)
27. Lufteinlass

* Die Smart-Fernsteuerung erreicht ihre maximale Übertragungsdistanz (FCC konform) in einer Höhe von etwa 120 m (offenes Gelände, ohne elektromagnetische Interferenzen). Die maximale Laufzeit wurde unter Laborbedingungen getestet. Dieser Wert dient nur als Referenz.

1. Video-Tutorials ansehen

Schauen Sie sich die Tutorial-Videos unter folgender Adresse an:
www.dji.com/mavic-2-enterprise/info#video.



Video-Tutorials

2. Fluggerät vorbereiten

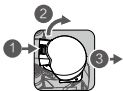

Entfernen Sie die Gimbal-Abdeckung von der Kamera.



Klappen Sie die vorderen Arme aus.



Klappen Sie die hinteren Arme aus.



Markiert



Nicht markiert

Ordnen Sie die Propeller den richtigen Motoren zu.



Drücken Sie die Propeller herunter, und drehen Sie sie in die Verriegelungsrichtung.



Ausgeklappt



Klappen Sie die vorderen Arme und die Propeller aus, bevor Sie die hinteren Arme ausklappen. Vor dem Losfliegen müssen alle Arme und Propeller ausgeklappt sein.

3. Die Akkus laden

Verwenden Sie das im Lieferumfang enthaltene Ladegerät, um die Intelligent Flight Battery vor der ersten Verwendung vollständig aufzuladen.

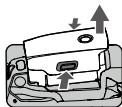

Intelligent Flight Battery entnehmen.

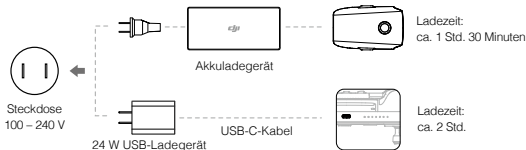

Bitte Nutzen Sie zum Laden der Smart-Fernsteuerung das offizielle 24W USB-Ladegerät. Sollte das offizielle 24W USB-Ladegerät nicht verfügbar sein, empfehlen wir Ihnen ein CE-zertifiziertes USB-Ladegerät mit 12V/2A.

*Ladezustand prüfen und Ein/Ausschalten

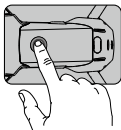

Drücken Sie die Taste einmal, um den Akku-Ladezustand zu überprüfen.
Drücken Sie die Taste einmal kurz und dann lang, um das Gerät ein-/auszuschalten.

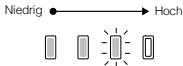
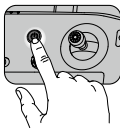

Drücken Sie die Taste einmal, um den Akkuladezustand auf dem LCD-Display zu überprüfen.
Drücken Sie die Taste noch einmal, und halten Sie sie gedrückt, um die Fernsteuerung ein-/auszuschalten.



Legen Sie den Akku in die Drohne und schalten Sie diese ein. Kühlt sich der Akku auf weniger als 6°C ab, erwärmt sich dieser automatisch, um seine Temperatur zwischen 8 und 10 °C zu halten. Für weitere Details schauen Sie bitte in der Bedienungsanleitung nach.

4. Fernsteuerung vorbereiten

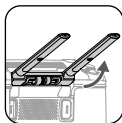

Klappen Sie die Antennen aus



Entnehmen Sie die Steuerknüppel



Drehen Sie die Knüppel in die Fernsteuerung

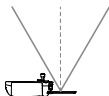
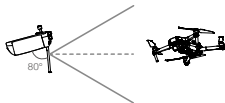
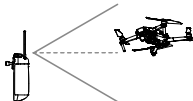

Der optimale Übertragungsbereich ist oben gezeigt. Stellen Sie sicher, dass die Antennenflächen auf das Fluggerät ausgerichtet sind. Wenn der Winkel zwischen den Antennen und der Rückseite der Smart-Fernsteuerung 80° oder 180° beträgt, kann die Verbindung zwischen der Smart-Fernsteuerung und dem Fluggerät ihre optimale Leistung erbringen.

Die obigen Abbildungen zeigen Situationen, in denen der Pilot und das Fluggerät weit voneinander entfernt sind.



- Stellen Sie sicher, dass die Steuerknüppel fest montiert sind.
- Im realen Betrieb wird die DJI Pilot App eine Warnung ausgeben, dass das Übertragungssignal schwach ist. Richten Sie dann die Antennen so aus, dass das Fluggerät wieder im optimalen Übertragungsbereich ist.

5. Vorbereitung für den Start



Fernsteuerung einschalten



Fluggerät einschalten



DJI Pilot starten



Internet

Verwenden Sie ein DJI Benutzerkonto zur Aktivierung des Fluggeräts und der Smart-Fernsteuerung. Die Aktivierung setzt eine Internetverbindung voraus. Schalten Sie vor der Aktivierung des Fluggeräts in DJI Pilot die Smart-Fernsteuerung ein und folgen Sie den Anweisungen zur Aktivierung.



Legen Sie in der DJI Pilot App bitte ein Passwort für die Drohne fest und sichern somit den Zugriff auf den internen Speicher ab.

6. Flug

Vergewissern Sie sich vor dem Losfliegen, dass die Statusleiste in DJI Pilot „Bereit“ anzeigt.

Ready to Go (GPS)

* Automatisches Starten/Landen

Knüppelkombination zum Ein-/Ausschalten der Motoren



Linken Knüppel langsam nach oben bewegen, um zu starten



Drücken Sie den linken Knüppel nach unten (langsam), bis das Fluggerät den Boden berührt. Einige Sekunden halten, um die Motoren auszuschalten



Schalten Sie die Motoren während des Fluges nur ab, wenn dadurch in einem Notfall Verletzungen oder Schäden vermieden werden können. Die Methode zum Stoppen der Motoren kann in DJI Pilot eingestellt werden.

* Die Fernsteuerung verwenden

Die Standard-Flugsteuerung wird als Modus 2 bezeichnet. Mit dem linken Steuerknüppel steuern Sie die Höhe und Flugrichtung des Fluggeräts, und mit dem rechten Steuerknüppel steuern Sie ihre Vorwärts-, Rückwärts-, Links- oder Rechtsbewegung. Mit dem Gimbal-Rädchen wird die Neigung der Kamera verstellt.

Linker Knüppel



Steigflug



Sinkflug



Linksdrehung

Rechtsdrehung

Rechter Knüppel



Vorwärts



Rückwärts



Links

Rechts



- Stellen Sie vor jedem Start immer eine geeignete Höhe für die Rückkehrfunktion ein. Wenn das Fluggerät zum Startpunkt zurückkehrt, sollten Sie es mit den Steuerknüppeln korrigieren, falls nötig.
- Drücken Sie die Taste „Flugpausentaste“ zur Notbremsung während des Fluges.

* Modulares Zubehör



M2E Kollisionswarnlicht



M2E Scheinwerfer



M2E Lautsprecher

7. Sicher fliegen



Nur in offenen
Bereichen fliegen

+



Starkes
GPS-Signal

+



Sichtkontakt
behalten

+



Fliegen Sie unterhalb
von 120 m.



Über- und umfliegen Sie Hindernisse, Menschenmengen, Hochspannungsleitungen, Bäume und Gewässer stets mit ausreichendem Sicherheitsabstand.

Fliegen Sie NICHT in die Nähe elektromagnetischer Quellen (z. B. Hochspannungsleitungen, Basisstationen), da die Funktion des Bordkompasses dadurch gestört werden kann.



Fliegen Sie NICHT bei widrigem Wetter (z. B. Regen, Schnee, Nebel oder Windgeschwindigkeiten über 10 m/s).



Halten Sie ausreichend Abstand zu den
drehenden Propellern und Motoren.



Flugverbotszonen
(GEO-Zone)

Mehr Informationen:
<http://flysafe.dji.com/no-fly>



Um Ihre eigene Sicherheit und die Sicherheit der Menschen in Ihrer Umgebung zu gewährleisten, ist es wichtig, dass Sie die nötigen Grundregeln kennen. Lesen Sie sich den **Haftungsausschluss und die Sicherheitsvorschriften** durch..

Technische Daten

• Fluggerät

Gewicht	899 g
Max. Fluggeschwindigkeit	72 km/h im Sportmodus ohne Wind
Max. Dienstgipfelhöhe über N.N.	6.000 m
Betriebstemperatur	-10° bis 40 °C
GNSS	GPS + GLONASS
Betriebsfrequenz	2,4-2,4835 GHz; 5,725-5,850 GHz
Sendeleistung (EIRP)	2,4 GHz FCC: ≤26 dBm; CE/MIC: ≤ 20 dBm; SRRC: ≤20 dBm 5,8 GHz FCC: ≤26 dBm; CE: ≤14 dBm; SRRC: ≤26 dBm 24 GB
Interner Speicher	

• Gimbal

Kontrollierter Bereich	Nickachse: -90° bis +30°
------------------------	--------------------------

• Wärmebildkamera

Sensor	Ungekühltes VOx-Mikrobolometer
Objektiv	Horizontales Sichtfeld: 57° Blende: F1.1
Pixelabstand	12 µm
Spektralband	8–14 µm
Max. Bildgröße	640 × 480 (4:3); 640 × 360 (16:9)
Fotomodi	Einzelaufnahme Serienbildaufnahmen: 3/5/7 Bilder Intervall (2/3/5/7/10/15/20/30/60 s)
Videomodi	640 × 360 bei 8,7 Bildern/s
Genauigkeit	Hohe Verstärkung: Max. ± 5 % (typischer Wert) Geringe Verstärkung: Max. ± 10 % (typischer Wert)
Aufnahmebandbreite	Hohe Verstärkung: -10 °C bis +140 °C Geringe Verstärkung: -10 °C bis +400 °C
Fotoformate	JPEG
Videoformate	MP4, MOV (MPEG-4 AVC/H.264)

• Sichtkamera

Sensor	1/2,3-Zoll-CMOS; effektive Pixel: 12 Megapixel
Objektiv	Sichtfeld: ca. 85 ° 35 mm Format Äquivalent: 24 mm Blende: F2.8 Fokus: 0,5 m bis ∞
ISO-Bereich	Video: 100–12800 (automatisch) Foto: 100–1600 (automatisch)
Max. Bildgröße	4056 × 3040(4:3); 4056 × 2280(16:9)
Fotomodi	Einzelaufnahme Serienbildaufnahmen: 3/5/7 Bilder Intervall (2/3/5/7/10/15/20/30/60 s)
Videomodi	4K Ultra HD: 3840 × 2160 30p 2,7K: 2688 × 1512 30p Full HD: 1920 × 1080 30p
Max. Video-Bitrate	100 MBit/s
Fotoformate	JPEG
Videoformate	MP4, MOV (MPEG-4 AVC/H.264)

• DJI Smart-Fernsteuerung

Akku	5000mAh @ 7,2V
Betriebstemperatur	-20° bis 40° C
Speicherkapazität	ROM 16 GB (erweiterbar über microSD-Karte)
OcuSync 2.0	
Betriebsfrequenzen	2,400 - 2,483 GHz; 5,725 - 5,850 GHz
Max. Übertragungsreichweite	10 km (FCC); 6 km (CE/MIC); 6 km (SRRC) (Ohne Hindernisse und Interferenzen)
Strahlungsleistung (EIRP)	2,4 GHz FCC: ≤25,5 dBm; CE/MIC: ≤18,5 dBm; SRRC: ≤19 dBm
	5,8 GHz FCC: ≤25,5 dBm; CE: ≤12,5 dBm; SRRC: ≤18,5 dBm
Wi-Fi	
Protokolle	Wi-Fi Direct, WiFi Display, 2x2 MIMO, und 802.11a/g/n/ac
Betriebsfrequenzen	2,4-2,4835 GHz; 5,150-5,250 GHz; 5,725-5,850 GHz
Strahlungsleistung (EIRP)	2,4 GHz FCC: ≤21,5 dBm; CE/SRRC: ≤18,5 dBm; MIC: ≤20,5 dBm
	5,2 GHz FCC/CE/SRRC/MIC: ≤19 dBm
	5,8 GHz FCC/SRRC: ≤21 dBm; CE: ≤13 dBm
Bluetooth	
Protokolle	Bluetooth 4.2
Betriebsfrequenzen:	2,4-2,4835 GHz
Strahlungsleistung (EIRP)	≤4 dBm
• Akkuladegerät	
Spannung	17,6 ± 0,1 V
Nennleistung	60 W
• Intelligent Flight Battery	
Kapazität	3850 mAh
Spannung	17,6 V (max.) 15,4 V (normal)
Akkutyp	LiPo 4S
Energie	59,29 Wh
Nettogewicht	ca. 297 g
Ladetemperatur	5 bis 40 °C
Max. Ladeleistung	80 W
Temperaturbereich der Selbsterwärmung	-20° bis 6° C
Dauer der Selbsterwärmung	Max. 600 Sekunden
Selbsterwärmungsleistung	Max. 35 Watt
• 24 W USB-Ladegerät	
Eingang	100-240 V~50/60 Hz, Max. 0,8 A
Ausgang	3,6-8 V ≙ 3,0 A / 12 V ≙ 2,0 A
※ Lokale Vorschriften in einigen Ländern verbieten die Verwendung der Frequenzbänder um 5,8 GHz und 5,2 GHz. In einigen Regionen ist das 5,2 GHz-Frequenzband nur für den Innenbereich zugelassen.	

Nähere Informationen finden Sie in der Bedienungsanleitung:

www.dji.com/mavic-2-enterprise

※ Der Inhalt kann jederzeit unangekündigt geändert werden.

MAVIC ist eine Marke von DJI.

Copyright © 2020 DJI Alle Rechte vorbehalten.

Gedruckt in China.

Aeronave

El MAVIC™ 2 Enterprise Dual de DJI™ cuenta con un sistema de detección omnidireccional con sensores de visión e infrarrojos* y viene con una cámara con estabilizador de 3 ejes con una cámara térmica de onda larga FLIR y una cámara visual, gracias a las que puede capturar imágenes tanto imágenes tanto en el espectro infrarrojo como en el visible simultáneamente. Las tecnologías características de DJI, tales como la detección de obstáculos, le ayudan a volar y le permiten capturar tomas complejas sin esfuerzo. Otras funciones como AirSense le permiten ser consciente de su espacio aéreo circundante y la protección por contraseña le ayuda a mantener asegurado el acceso a su aeronave y a proteger su información. El Mavic 2 Enterprise tiene además módulos accesorios como el Foco M2E, la Baliza M2E y el Altavoz M2E, diseñados para una gran variedad de usos. Mavic 2 Enterprise alcanza una velocidad de vuelo máxima de 72 km/h (44,7 mph) y un tiempo máximo de vuelo de 31 minutos**.

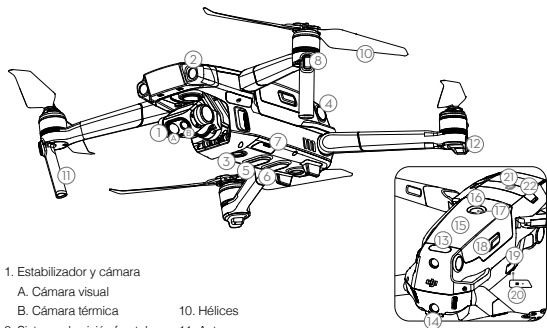

1. Estabilizador y cámara

- A. Cámara visual
- B. Cámara térmica

2. Sistema de visión frontal

3. Sistema de visión inferior

4. Sistema de visión lateral

5. Sistema de detección inferior por infrarrojos

6. Luz inferior auxiliar

7. Ranura para tarjeta microSD

8. Indicadores LED delanteros

9. Motores

10. Hélices

11. Antenas

12. Indicador de estado de la aeronave

13. Sistema de detección superior por infrarrojos

14. Sistema de visión de retroceso

15. Batería de Vuelo Inteligente

16. Indicadores LED de nivel de batería

17. Botón de encendido

18. Bandas de sujeción de la batería

19. Puerto USB-C

20. Botón de vinculación/ indicador de estado de vinculación

21. Puerto de accesorios

22. Tapa del puerto de accesorios

* El sistema de visión y el sistema de detección por infrarrojos se ven afectados por las condiciones del entorno.

Lea la Renuncia de responsabilidad y directrices de seguridad, el Manual del usuario y vea los vídeos tutoriales en la página web de DJI para más información. <http://www.dji.com/mavic-2-enterprise>

** El tiempo máximo de vuelo se determinó en un entorno sin viento a una velocidad sostenida de 25 km/h (15,5 mph). Este valor se proporciona sólo como referencia.

DJI Smart Controller

El DJI Smart Controller es un control remoto que incorpora OCUSSYNC™ 2.0, la tecnología de transmisión de largo alcance de DJI, gracias al cual permite tener una visión en HD de lo que ve la cámara de la aeronave a una distancia de 10 km (6.2 millas). El Smart Controller incluye controles para varias aeronaves y cámaras, además de botones configurables. Tiene también una pantalla de 5.5 pulgadas y de alto brillo con funciones como Bluetooth y GNSS. Puede conectarse a Internet mediante Wi-Fi. El Smart Controller tiene un tiempo máximo de funcionamiento de 2.5 horas*.

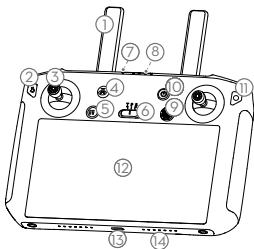

1. Antenas
2. Botón atrás y funciones
3. Palancas
4. Botón RTH
5. Botón de detener vuelo
6. Selector de modo de vuelo
7. Indicador LED de estado
8. Indicadores LED del nivel de la batería
9. Botón 5D
10. Botón de encendido
11. Botón de confirmación y botón C3 personalizable
12. Pantalla táctil
13. Puerto USB-C
14. Micrófono
15. Dial del estabilizador



16. Botón de grabación
17. Puerto HDMI
18. Ranura para tarjeta microSD
19. Puerto USB-A
20. Botón del obturador y enfoque
21. Dial de ajuste de la apertura / del obturador

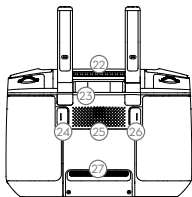

22. Salida de aire
23. Ranura de almacenamiento de palancas
24. Botón C2 personalizable
25. Altavoz
26. Botón C1 personalizable
27. Entrada de aire

* El Smart Controller alcanza su distancia máxima de transmisión (siguiendo las normas de la FCC) en un área abierta y amplia sin interferencias electromagnéticas y a una altitud de unos 120 metros (400 pies). El tiempo de funcionamiento máximo se ha probado en un entorno de laboratorio. Este valor se proporciona sólo como referencia.

1. Ver vídeos tutoriales

Mire los vídeos tutoriales en www.dji.com/mavic-2-enterprise/info#video.



Videotutoriales

2. Preparación de la aeronave

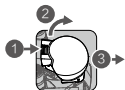

Retire la cubierta del estabilizador de la cámara.



Despliegue los brazos delanteros.



Despliegue los brazos traseros.

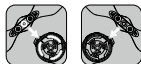

Con marca Sin marca
Empareje las hélices con los motores.



Presione las hélices hacia abajo firmemente y gírelas en la dirección de bloqueo.



Desplegado



Despliegue los brazos y hélices frontales antes que los posteriores. Todos los brazos y hélices deben estar desplegados antes del despegue.

3. Carga de las baterías

Utilice el cargador suministrado para cargar completamente la Batería de Vuelo Inteligente antes del primer uso.

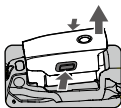

Extraiga la Batería de Vuelo Inteligente

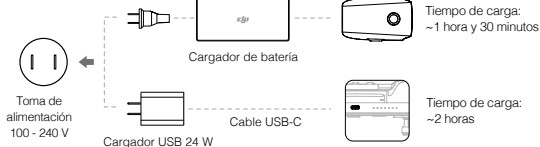

Por favor utilice el cargador USB oficial de 24 W para cargar el Smart Controller. Si no dispone de un cargador USB estándar de 24 W, se recomienda utilizar un cargador USB con certificación FCC/CE con una potencia nominal de 12 V/2 A

* Comprobar los niveles de batería y encendido/apagado

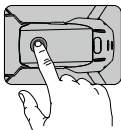

Pulse una vez para comprobar el nivel de batería.

Pulse una vez, después otra y mantenga pulsado para encender o apagar.

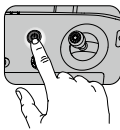

Bajo Alto

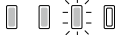

Pulse una vez para comprobar el nivel de batería en la pantalla LCD.

Pulse una vez, después otra y mantenga pulsado para encender o apagar el control remoto.



Instale la batería en la aeronave y enciéndala. Si la temperatura de la batería desciende por debajo de 6 °C, se autocalentará para mantener una temperatura de entre 8 y 10 °C. Consulte el Manual de usuario para más detalles.

4. Preparación del controlador remoto



Levante las antenas



Retire las palancas



Gire para unir las palancas

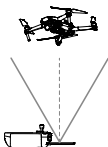
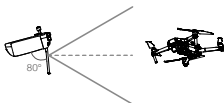
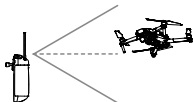

El intervalo de transmisión óptimo se muestra arriba. Asegúrese de que las antenas estén orientadas hacia la aeronave. Cuando el ángulo entre las antenas y la parte posterior del Control Remoto Inteligente sea de 80° o 180°, la conexión entre el Control Remoto Inteligente y la aeronave podrá alcanzar su rendimiento óptimo.

Las ilustraciones de arriba muestran situaciones en las que el operador y la aeronave están lejos.



- Compruebe que las palancas de control estén bien montadas.
- Durante el funcionamiento real, la aplicación DJI Pilot le mostrará una advertencia cuando la señal de transmisión sea débil. En ese caso, ajuste las antenas para asegurarse de que la aeronave vuelva al intervalo de transmisión óptimo.

5. Preparación para el despegue



Encienda el controlador remoto.



Encienda la aeronave.



Inicie DJI Pilot.



Utiliza una cuenta DJI para activar la aeronave y el Smart Controller. Se requiere una conexión a Internet para la activación. Antes de activar la aeronave en DJI Pilot, encienda el Smart Controller y siga las indicaciones para activarlo.



Establezca una contraseña para la aeronave con la aplicación DJI Pilot para garantizar la seguridad de los datos de a bordo.

6. Vuelo

Antes de despegar, asegúrese de que la barra de estado de la aeronave en la aplicación DJI Pilot muestre "Ready to Go".

Ready to Go (GPS)

* Despegue/aterrizaje manuales

Comando de combinación de palancas para arrancar/detener los motores



O bien



Palanca izquierda arriba (despacio) para despegar



Palanca izquierda abajo (despacio) hasta tocar suelo
Mantenga unos segundos para detener los motores



Para reducir el riesgo de daños o lesiones, detenga los motores en pleno vuelo solo en situaciones de emergencia. El método para detener los motores puede configurarse en DJI Pilot.

* Funcionamiento del control remoto

El control de vuelo predeterminado se conoce como Modo 2. La palanca izquierda controla la altitud y la dirección de la aeronave, mientras que la derecha controla los movimientos hacia delante, atrás, izquierda y derecha. El selector del estabilizador controla la inclinación de la cámara.

Palanca izquierda



Palanca derecha



- Establezca siempre una altitud de RTH (Regreso al punto de origen) adecuada antes del despegue. Cuando la aeronave esté volviendo al punto de origen, debe guiarla con las palancas de control.
- Pulse el botón de pausa de vuelo para una frenada de emergencia durante el vuelo.

* Módulos accesorios



Baliza M2E



Foco M2E



Altavoz M2E

7. Vuelo seguro



Vuele en espacios abiertos

+



Señal fuerte de GPS

+



Mantenga una línea de visión directa

+



Vuele por debajo de 120 m (400 pies)



Evite volar por encima o cerca de obstáculos, multitudes, líneas de alta tensión, árboles o masas de agua.

NO vuele cerca de fuentes electromagnéticas, como tendidos eléctricos y estaciones base, ya que puede afectar a la brújula de a bordo.



NO utilice la aeronave en condiciones climáticas adversas como lluvia, nieve, niebla ni con una velocidad del viento superior a 10 m/s o 22 mph.



Manténgase alejado de las hélices y los motores en rotación.



Zona GEO

Obtenga más información en:
<http://fllysafe.dji.com/no-fly>



Es importante conocer las directrices básicas de vuelo para su propia seguridad y la de quienes le rodean. NO olvide leer la **Renuncia de responsabilidad** y las **directrices de seguridad**.

Especificaciones

• Aeronave

Peso	899 g
Velocidad máxima	72 km/h (44,7 mph) en modo Sport sin viento
Altitud de servicio máxima por encima del nivel del mar	6000 m (19685 ft)
Temperatura de funcionamiento	-10 a 40 °C (14 a 104 °F)
GNSS	GPS + GLONASS
Frecuencia de funcionamiento	2,4-2,4835 GHz; 5,725-5,850 GHz
Potencia del transmisor (PIRE)	2,4 GHz FCC: ≤ 26 dBm; CE/MIC: ≤ 20 dBm; SRRC: ≤ 20 dBm 5,8 GHz FCC: ≤ 26 dBm; CE: ≤ 14 dBm; SRRC: ≤ 26 dBm
Almacenamiento interno	24 GB

• Estabilizador

Intervalo controlable	Cabeceo: -90° a +30°
-----------------------	----------------------

• Cámara térmica

Sensor	Microbolómetro VOx no refrigerado
Objetivo	HFOV: 57° Apertura: f/1.1
Rejilla de píxel	12 µm
Banda espectral	8-14 µm
Tamaño de imagen	640×480 (4:3); 640×360 (16:9)
Modos de fotografía	Disparo único Disparo en ráfaga: 3/5/7 fotografías Intervalo (2/3/5/7/10/15/20/30/60 s) 640×360 a 8.7 fps
Modos de vídeo	Alta ganancia: Máx. ± 5 % (de media)
Precisión	Baja ganancia: Máx. ± 10 % (de media)
Rango de escena	Alta ganancia: -10 °C a + 140 °C Baja ganancia: -10 °C a + 400 °C
Fotografía	JPEG
Vídeo	MP4, MOV (MPEG-4 AVC/H.264)

• Cámara visual

Sensor	CMOS de 1/2,3"; píxeles efectivos: 12 MP
Objetivo	FOV: aprox. 85° Formato equivalente a 35 mm: 24 mm Apertura: f/2.8 Enfoque: 0,5 m a ∞
Rango ISO	Vídeo: 100-12800 (automática) Fotografía: 100-1600 (automática)
Tamaño máx. de imagen	4056 × 3040(4:3)4056×2280(16:9)
Modos de fotografía	Disparo único Disparo en ráfaga: 3/5/7 fotografías Intervalo (2/3/5/7/10/15/20/30/60 s)
Modos de vídeo	4K Ultra HD:3840×2160 30p 2.7K:2688×1512 30p Full HD:1920×1080 30p
Tasa de bits máx. de almacenamiento de vídeo	100 Mbps
Fotografía	JPEG
Vídeo	MP4, MOV (MPEG-4 AVC/H.264)

• Smart Controller

Batería	5000 mAh a 7.2 V
Rango de temperatura de funcionamiento	De -20 a 40 °C (de -4 a 104 °F)
Capacidad de almacenamiento	ROM 16 GB + Escalable (tarjeta microSD)
OcuSync 2.0	
Frecuencia de funcionamiento	2.4-2.4835 GHz; 5.725-5.850 GHz
Distancia de Transmisión Máx	10 km (FCC); 6 km (CE/MIC); 6 km (SRRC) (Sin obstáculos, libre de interferencias)
Potencia del transmisor (PIRE)	2.4 GHz FCC: ≤25.5 dBm; CE/MIC: ≤18.5 dBm; SRRC: ≤19 dBm 5.8 GHz FCC: ≤26 dBm; CE: ≤12.5 dBm; SRRC: ≤18.5 dBm
Wi-Fi	
Protocolo	Wi-Fi Direct, Wireless Display, 2x2 MIMO y 802.11a/g/n/ac
Frecuencia de funcionamiento	2.4-2.4835 GHz; 5.150-5.250 GHz; 5.725-5.850 GHz
Potencia del transmisor (PIRE)	2.4 GHz FCC: ≤21.5 dBm; CE/SRRC: ≤18.5 dBm; MIC: ≤20.5 dBm 5.2 GHz FCC/CE/SRRC/MIC: ≤19 dBm 5.8 GHz FCC/SRRC: ≤21 dBm; CE: ≤13 dBm

Bluetooth

Protocolo	Bluetooth 4.2
Frecuencia de funcionamiento	2.4-2.4835 GHz
Potencia del transmisor (PIRE)	≤4 dBm

* Cargador de batería

Voltaje	17,6±0,1 V
Potencia nominal	60 W

* Batería de Vuelo Inteligente

Capacidad	3850 mAh
Voltaje	17,6 V (máx.) 15,4 V (típico)
Tipo de batería	LiPo 4S
Energía	59,29 Wh
Peso neto	Aprox. 297 g
Intervalo de temperatura de carga	De 5 °C a 40 °C (de 41 °F a 104 °F)
Potencia de carga máx.	80 W
Intervalo de temperatura de autocalentamiento	de -20° a 6° C (de -4° a 43° F)
Tiempo de autocalentamiento	600 s (máx)
Potencia de autocalentamiento	35 W (máx)

* Cargador USB de 24 W

Entrada	100 - 240 V ~ 50/60 Hz, Máx. 0.8 A
Salida	3.6-8 V = 3.0 A / 12 V = 2.0 A

※ Las normas locales de algunos países prohíben el uso de frecuencias de 5,8 GHz y 5,2 GHz, y en algunas regiones la banda de frecuencia de 5,2 GHz solo está permitida para uso en interiores.

Para obtener más información, lea el manual del usuario:

www.dji.com/mavic-2-enterprise

※ Este contenido puede modificarse sin notificación previa.

MAVIC es una marca comercial de DJI.

Copyright © 2020 DJI Todos los derechos reservados.

Impreso en China.

Appareil

Le DJI™ MAVIC™ 2 Enterprise Dual propose des systèmes optiques multidirectionnels et des systèmes de détection infrarouge*. Il est livré avec une caméra à nacelle 3 axes entièrement stabilisée avec une caméra thermique infrarouge à ondes longues FLIR et une caméra optique, fournissant simultanément des images thermiques et visuelles. Les technologies emblématiques de DJI telles que la détection d'obstacles vous aident à piloter et à réaliser des prises de vue complexes sans effort. Des fonctionnalités supplémentaires comme le DJI AirSense intégré vous permettent de connaître l'espace aérien environnant, tandis que la protection par mot de passe vous aide à sécuriser l'accès à votre drone et à protéger vos données. Le Mavic 2 Enterprise dispose également d'accessoires modulaires amovibles tels que le projecteur, le phare et le haut-parleur qui sont spécialement conçus pour diverses applications. Le Mavic 2 Enterprise peut se targuer d'une vitesse de vol maximale de 72 km/h (44,7 mph) et d'un temps de vol maximum de 31 minutes**.

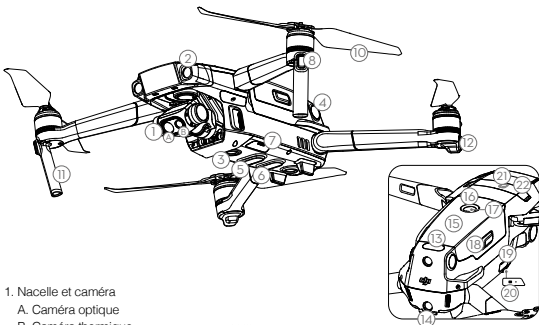

1. Nacelle et caméra

- A. Caméra optique
- B. Caméra thermique

2. Système optique avant

3. Système optique inférieur

4. Système optique latéral

5. Système de détection infrarouge vers le bas

6. Lampe inférieure

7. Logement de la carte microSD

8. LED avant

9. Moteurs

10. Hélices

11. Antennes

12. Voyant d'état de l'appareil

13. Système de détection infrarouge vers le haut

14. Système optique arrière

15. Batterie de Vol Intelligente

16. Indicateurs de niveau de batterie

17. Bouton d'alimentation

18. Bouton presseur de la batterie

19. Port USB-C

20. Bouton d'appairage/voyant d'état d'appairage

21. Port d'extension (pour connecter les accessoires)

22. Couverture port d'extension

* Les systèmes infrarouge et de vision sont influencés par les conditions environnementales. Lisez la clause d'exclusion de responsabilité et les consignes de sécurité ainsi que le guide de l'utilisateur, et regardez les tutoriels vidéo sur le site web officiel de DJI pour en savoir plus. <http://www.dji.com/mavic-2-enterprise>

** Le temps de vol maximum a été testé en l'absence de vent, à une vitesse constante de 25 km/h (15,5 mph). Cette valeur est fournie à titre indicatif uniquement.

Radiocommande Smart Controller de DJI

La DJI Smart Controller est une radiocommande conçue avec la technologie de transmission longue portée OCUSYNC™ 2.0 de DJI, offrant une portée de transmission maximale de 10 km et des images HD en direct depuis la caméra de l'appareil. La Smart Controller intègre un certain nombre de commandes de drone et de nacelle ainsi que des boutons personnalisables. La radiocommande intelligente possède également un écran intégré de 5,5 pouces à haute luminosité avec de multiples fonctions telles que Bluetooth et GNSS. Elle peut être connectée à Internet via Wi-Fi. La radiocommande dispose d'une autonomie de fonctionnement maximale de 2,5 heures*.

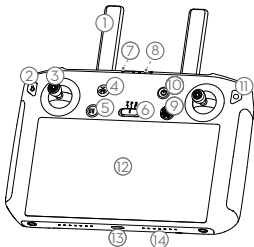

1. Antennes
2. Bouton Retour/Bouton Fonction
3. Joysticks
4. Bouton RTH
5. Bouton de mise en pause du vol
6. Bouton de mode de vol
7. Voyant LED
8. Indicateurs de niveau de batterie
9. Bouton 5D
10. Bouton d'alimentation
11. Bouton de confirmation/
Bouton personnalisable C3
12. Écran tactile
13. Port USB-C
14. Microphone
15. Molette pour nacelle



16. Bouton d'enregistrement
17. Port HDMI
18. Logement de la carte microSD
19. Port USB-A
20. Bouton de mise au point/de l'obturateur
21. Bouton de réglage de l'ouverture ou l'obturateur

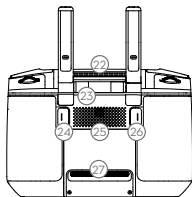

22. Ventilation
23. Emplacement de rangement des joysticks
24. Bouton personnalisable C2
25. Haut-parleur
26. Bouton personnalisable C1
27. Entrée d'air

* La Smart Controller est capable d'atteindre sa distance de transmission maximale (FCC) dans un espace dégagé sans interférence électromagnétique, à une altitude d'environ 120 m.

Le temps d'exécution maximum a été testé dans un environnement de laboratoire. Cette valeur est fournie à titre indicatif uniquement.

1. Regarder des tutoriels vidéo

Regardez les tutoriels vidéo sur www.dji.com/mavic-2-enterprise/info#video.



Didacticiels vidéo

2. Préparation de l'appareil

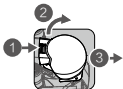

Retirez le cache de la nacelle de la caméra.



Dépliez les bras avant.



Dépliez les bras arrière.

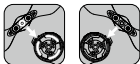

Marqué Non marqué

Associez les hélices aux moteurs correspondants.



Montez solidement l'hélice, puis tournez dans la direction de verrouillage.



Déplié



Dépliez les bras avant et les hélices avant ceux situés à l'arrière. Tous les bras et les hélices doivent être dépliés avant le décollage.

3. Chargement des batteries

Chargez entièrement la Batterie de Vol Intelligente à l'aide du chargeur fourni avant la première utilisation.

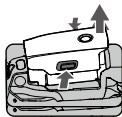

Retirez la Batterie de Vol Intelligente

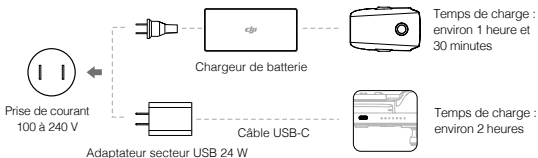

Veuillez utiliser l'adaptateur secteur USB officiel de 24 W pour charger la Smart Controller. Si un adaptateur secteur USB standard de 24 W n'est pas disponible, il est recommandé d'utiliser un adaptateur secteur certifié FCC/CE de 12V/2A.

* Vérification des niveaux de batterie et mise sous/hors tension

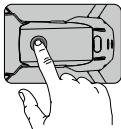

Appuyez une fois pour vérifier le niveau de la batterie.
Appuyez, puis maintenez enfoncé pour allumer/éteindre.

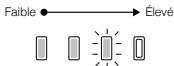
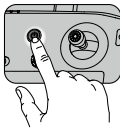

Appuyez une fois pour vérifier le niveau de batterie sur l'écran LCD.
Appuyez, puis maintenez enfoncé pour allumer/éteindre la radiocommande.



Installez la batterie dans l'appareil et mettez-le sous tension. Une fois que la température de la batterie est inférieure à 6°C, elle se réchauffe automatiquement pour maintenir une température entre 8 et 10°C. Reportez-vous au guide d'utilisateur pour plus de détails.

4. Préparation de la radiocommande

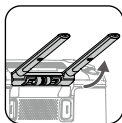

Levez les antennes



Retirez les joysticks



Tournez pour installer
les joysticks

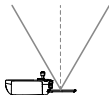
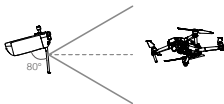
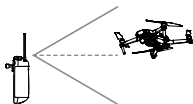

La portée de transmission optimale est indiquée ci-dessus. Vérifiez que les antennes sont tournées vers l'appareil. Un angle de 80° ou 180° entre les antennes et l'arrière de la Smart Controller assure une connexion optimale entre l'appareil et la Smart Controller.

Les illustrations ci-dessus montrent des situations où l'opérateur et l'appareil sont éloignés.



- Assurez-vous que les manches de contrôle sont bien en place.
- En fonctionnement réel, l'application DJI Pilot vous avertira si le signal de transmission devient faible. Dans ce cas, ajustez les antennes pour retrouver la portée de transmission optimale.

5. Préparation au décollage



Mettez la radiocommande sous tension



Mettez l'appareil sous tension



Lancez DJI Pilot



Internet

Utilisez un compte DJI pour activer l'appareil et la Smart Controller. L'activation nécessite une connexion à Internet. Avant d'activer l'appareil sur DJI Pilot, allumez la Smart Controller et suivez les instructions d'activation.



Définissez un mot de passe pour le drone dans l'application DJI Pilot afin de sécuriser l'accès et de protéger vos données embarquées.

6. Vol

Avant de procéder au décollage, vérifiez dans DJI Pilot que la mention « Ready to Go » s'affiche dans la barre d'état de l'appareil.

Ready to Go (GPS)

• Décollage/atterrissage manuel

Commande de manche combinée pour démarrer/couper les moteurs



OU



Relevez lentement le manche gauche pour décoller.



Abaissez lentement le manche gauche jusqu'à ce que l'appareil touche le sol. Maintenez la position pendant quelques secondes pour couper les moteurs.



Coupez les moteurs en plein vol uniquement s'il s'agit d'un cas d'urgence dans lequel cette action peut réduire le risque de dommage ou de blessure. La méthode pour arrêter les moteurs peut être définies dans DJI Pilot.

* Fonctionnement de la radiocommande

Le contrôle de vol par défaut est connu sous le nom de Mode 2. Le manche gauche agit sur l'altitude et l'orientation de l'appareil, tandis que le manche droit contrôle ses mouvements vers l'avant, l'arrière, la gauche et la droite. La molette de la nacelle contrôle l'inclinaison de la caméra.

Manche gauche

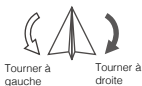

Manche droit



- Définissez toujours une altitude RTH appropriée avant le décollage. Lorsque l'appareil retourne au point de départ, guidez-le avec les manches de contrôle.
- Appuyez sur le bouton Pause de la fonction Vol pour effectuer un freinage d'urgence en plein vol.

* Accessoires modulaires



Phare M2E



Projecteur M2E



Haut-parleur M2E

7. Voler en toute sécurité



Faire voler l'appareil dans des espaces ouverts

+



Signal GPS fort

+



Garder l'appareil en vue

+



Voler à moins de 120 m d'altitude (400 pieds)



Évitez de faire voler l'appareil au-dessus ou à proximité d'obstacles, de rassemblements de personnes, de lignes électriques à haute tension, d'arbres ou d'étendues d'eau. Ne faites PAS voler l'appareil à proximité de sources électromagnétiques puissantes, telles que des lignes électriques ou des antennes relais. Celles-ci risquent en effet d'affecter le compas intégré.



N'utilisez PAS l'appareil dans de mauvaises conditions météorologiques (pluie, neige, brouillard, rafales dont la vitesse dépasse 10 m/s ou 35 km/h [22 mph], etc.).



Tenez-vous à distance des hélices et des moteurs en rotation.



Zone d'exclusion aérienne

Pour en savoir plus, rendez-vous sur le site : <http://flightsafe.dji.com/no-fly>



Il est important que vous compreniez les consignes de vol fondamentales afin d'assurer votre sécurité et celle de votre entourage. N'oubliez pas de lire la **Clause d'exclusion de responsabilité et les consignes de sécurité**.

Caractéristiques techniques

• Appareil

Poids	899 g
Vitesse max.	72 km/h (44,7 mph) en mode Sport sans vent
Plafond pratique max. au-dessus du niveau de la mer	6 000 m (19 685 pieds)
Température de fonctionnement	-10 à 40° C (14 à 104° F)
GNSS	GPS + GLONASS
Fréquence de fonctionnement	2,4 à 2,4835 GHz ; 5,725 à 5,850 GHz
Puissance de l'émetteur (EIRP)	2,4 GHz FCC : ≤ 26 dBm ; CE/MIC : 20 dBm ; SRRC : ≤ 20 dBm 5,8 GHz FCC : ≤ 26 dBm ; CE : 14 dBm ; SRRC : ≤ 26 dBm
Stockage interne	24 Go

• Nacelle

Plage réglable	Angle vertical : -90 à +30°
----------------	-----------------------------

• Caméra thermique

Capteur	Microbolomètre VOx non refroidi
Objectif	HFOV : 57° Ouverture : f/1.1
Pas de pixel	12 µm
Bande spectrale	8 - 14 µm
Taille d'image	640 × 480 (4:3) ; 640 × 360 (16:9)
Modes de photographie	Prise de vue unique Rafale : 3/5/7 images Intervalle (2/3/5/7/10/15/20/30/60 s)
Modes d'enregistrement vidéo	640 × 360 @ 8,7 i/s
Précision	Haut gain : max ± 5 % (standard) Bas gain : max ± 10 % (standard)
Plage de tournage	Haut gain : -10° à +140 °C Bas gain : -10° à +400 °C

Photo	JPEG
Vidéo	MP4, MOV (MPEG-4 AVC/H.264)

• Caméra optique

Capteur	CMOS 1/2.3" ; pixels effectifs : 12M
Objectif	FOV : environ 85° Format équivalent 35 mm : 24 mm Ouverture : f/2.8 Mise au point : 0,5 m à ∞
Gamme ISO	Vidéo : 100 à 12 800 (auto) Photo : 100 à 1 600 (auto)
Taille max. de l'image	4 056 × 3 040 (4:3) ; 4 056 × 2 280 (16:9)
Modes de photographie	Prise de vue unique Rafale : 3/5/7 images Intervalle (2/3/5/7/10/15/20/30/60 s)
Modes d'enregistrement vidéo	4K Ultra HD : 3 840 × 2 160 30p 2.7K : 2 688 × 1 512 30p FHD : 1 920 × 1 080 30p
Débit binaire max.	100 Mbps
Photo	JPEG
Vidéo	MP4, MOV (MPEG-4 AVC/H.264)

* Smart Controller

Batterie	5000 mAh @ 7,2 V
Plage de températures de fonctionnement	De -20 à 40 °C (de -4 à 104 °F)
Capacité de stockage	ROM 16 Go et extensible (carte microSD)
Ocusync 2.0	
Plage de fréquences de fonctionnement	2,4 - 2,4835 GHz ; 5,725-5,850 GHz
Distance de transmission max.	FCC : 10 km ; CE/MIC : 6 km ; SRRC : 6 km (sans obstacle ni interférence)
Puissance de l'émetteur (EIRP)	2,4 GHz FCC : ≤25,5 dBm ; CE/MIC : ≤18,5 dBm ; SRRC : ≤19 dBm 5,8 GHz FCC : ≤25,5 dBm ; CE : ≤12,5 dBm ; SRRC : ≤18,5 dBm

Wi-Fi

Protocole	Wi-Fi direct, affichage WiFi, 2 x 2 MIMO, et 802.11a/g/n/ac
Plage de fréquences de fonctionnement	2,4-2,4835 GHz ; 5,150-5,250 GHz ; 5,725-5,850 GHz
Puissance de l'émetteur (EIRP)	2,4 GHz FCC : ≤21,5 dBm ; CE/SRRC : ≤18,5 dBm ; MIC : ≤20,5 dBm 5,2 GHz FCC/CE/SRRC/MIC : ≤19 dBm 5,8 GHz FCC/SRRC : ≤21 dBm ; CE : ≤13 dBm

Bluetooth

Protocole	Bluetooth 4.2
Plage de fréquences de fonctionnement	2,4-2,4835 GHz
Puissance de l'émetteur (EIRP)	≤4 dBm

* Chargeur de batterie

Tension	17,6±0,1 V
Puissance nominale	60 W

* Batterie de Vol Intelligente

Capacité	3 850 mAh
Tension	17,6 V (max.), 15,4 V (standard)
Type de batterie	LiPo 4S
Énergie	59,29 Wh
Poids net	Env. 297 g
Plage de température de chargement	5° à 40 °C (41° à 104 °F)
Puissance de charge max.	80 W
Plage de température d'autochauffage	de -20° à 6° C (de -4° à 43° F)
Durée d'autochauffage	600 s (max.)
Puissance d'autochauffage	35 W (max.)

* Adaptateur secteur USB 24 W

Entrée	100-240 V~50/60 Hz, Max. 0,8 A
Sortie	3,6-8 V = 3,0 A / 12 V = 2,0 A

※ Les réglementations locales de certains pays interdisent l'utilisation des fréquences de 5,8 GHz et de 5,2 GHz et, dans certaines régions, la bande de fréquences de 5,2 GHz n'est autorisée que pour une utilisation en intérieur.

Pour en savoir plus, consultez le guide de l'utilisateur :

www.dji.com/mavic-2-enterprise

※ Ce contenu peut être modifié sans préavis.

MAVIC est une marque commerciale de DJI.

Copyright © 2020 DJI Tous droits réservés.

Imprimé en Chine.

Velivolo

DJI™ MAVIC™ 2 Enterprise Dual dispone di sistemi di visione omnidirezionale e sistemi di rilevamento a infrarossi*. È inoltre dotato di fotocamera gimbal stabilizzata a 3 assi, termocamera FLIR e fotocamera ottica, per acquisire, contemporaneamente, sia immagini a infrarossi che visive. Tecnologie proprietarie DJI, come il sistema di rilevamento degli ostacoli, offrono la possibilità di continuare a volare in totale sicurezza anche durante la realizzazione di riprese complesse. Caratteristiche aggiuntive come l'AirSense integrato vi rendono consapevoli dello spazio aereo circostante, mentre la protezione con password consente di mantenere un accesso sicuro al velivolo e proteggere i vostri dati. Mavic 2 Enterprise è anche dotato di accessori modulari aggiuntivi M2E quali il riflettore, il lampeggiante e l'altoparlante, che sono stati progettati per diversi utilizzi. Mavic 2 Enterprise vanta una velocità di volo massima di 72 km/h (44,7 mph) e un tempo di volo massimo** di 31 minuti.

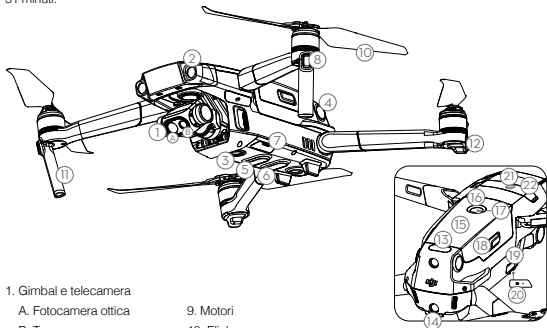

1. Gimbal e telecamera

- A. Fotocamera ottica
- B. Termocamera

2. Sistema visivo in avanti

3. Sistema visivo verso il basso

4. Sistema visivo laterale

5. Sistema di rilevamento a infrarossi verso il basso

6. Luce ausiliaria sulla parte inferiore

7. Slot per scheda micro-SD

8. LED anteriori

9. Motori

10. Eliche

11. Antenne

12. Indicatore di stato del velivolo

13. Sistema di rilevamento a infrarossi verso l'alto

14. Sistema visivo all'indietro

15. Batteria di volo intelligente

16. LED di livello di carica della batteria

17. Pulsante di accensione

18. Fermi della batteria

19. Porta USB-C

20. Pulsante di collegamento/
Indicatore di stato del
collegamento

21. Porta per gli accessori (per
collegare gli accessori)

22. Coperchio della porta per
gli accessori

* I sistemi visivi e i sistemi di rilevamento a infrarossi vengono influenzati dalle condizioni circostanti. Per maggiori informazioni, si prega di leggere le limitazioni di responsabilità e direttive sulla sicurezza, il manuale d'uso, e di guardare i video tutorial sul sito web ufficiale di DJI. <http://www.dji.com/mavic-2-enterprise>

** Il tempo massimo di volo è stato testato in assenza di vento e a una velocità costante di 25 km/h (15,5 mph). Questo valore viene fornito soltanto come riferimento.

Radiocomando DJI Smart

Il radiocomando DJI Smart è stato integrato con OCUSYNC™ 2.0, la tecnologia di trasmissione a distanza che opera fino a un raggio di 10 km e trasmette immagini dal vivo in HD dalla fotocamera del velivolo. Il radiocomando DJI Smart offre l'utilizzo di diversi comandi per il velivolo e il gimbal, oltre a una serie di pulsanti personalizzabili, e presenta uno schermo 5,5" ad alta luminosità dotato di diverse funzionalità, come Bluetooth e GNSS. Supporta, inoltre, la connessione a internet tramite Wi-Fi. Il radiocomando DJI Smart ha un'autonomia operativa di 2.5 ore*.

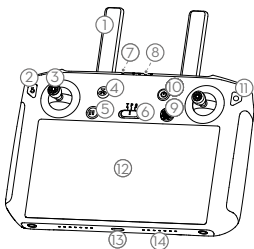

1. Antenne
2. Tasto Indietro/Tasto Funzione
3. Stick di controllo
4. Tasto RTH
5. Tasto di pausa del volo
6. Tasto selezione della modalità di volo
7. LED di stato
8. LED di carica della batteria
9. Tasto 5D
10. Tasto di accensione
11. Tasto Conferma / Tasto personalizzabile C3
12. Schermo touch
13. Porta USB-C
14. Microfono
15. Tasto di controllo del gimbal

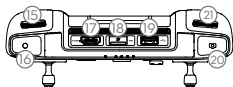

16. Tasto di registrazione
17. Porta HDMI
18. Slot per scheda microSD
19. Porta USB-A
20. Tasto di messa a fuoco / otturatore
21. Rotella di regolazione dell'apertura/otturatore

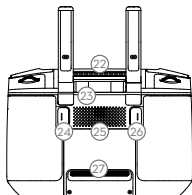

22. Bocchetta dell'aria
23. Comparto riponi-stick
24. Tasto personalizzabile C2
25. Altoparlante
26. Tasto personalizzabile C1
27. Presa d'aria

* Il radiocomando DJI Smart può raggiungere la sua massima distanza di trasmissione (a norma FCC) in aree aperte senza interferenze elettromagnetiche e a un'altitudine di circa 120 metri.

Il runtime massimo è testato in ambiente di laboratorio. Questo valore viene fornito soltanto come riferimento.

1. Visualizzazione dei tutorial

I video tutorial sono disponibili su www.dji.com/mavic-2-enterprise/info#video.



Video tutorial

2. Preparazione del velivolo

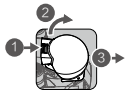

Rimuovere la protezione del gimbal dalla telecamera.



Dispiegare i bracci anteriori.



Dispiegare i bracci posteriori.

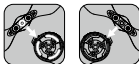

Contrassegnato Non contrassegnato

Far corrispondere le eliche ai motori



Premere con decisione le eliche verso il basso e ruotarle nella direzione di blocco.



Dispiegato



Dispiegare i bracci e le eliche anteriori prima di quelli posteriori. Tutti i bracci e le eliche devono essere dispiegati prima del decollo.

3. Ricarica delle batterie

Utilizzare il caricabatterie in dotazione per caricare completamente la batteria di volo intelligente prima di utilizzarla per la prima volta.

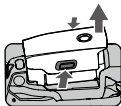

Rimuovere la batteria di volo intelligente

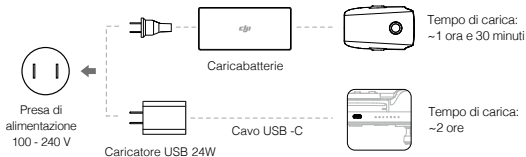

Si raccomanda di usare il caricatore USB 24W ufficiale per ricaricare il radiocomando DJI Smart. Qualora un caricatore USB 24W non fosse disponibile, si consiglia di usare un caricabatterie USB da 12V/2A certificato FCC/CE.

* Controllo dei livelli della batteria e accensione/spengimento

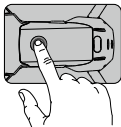

Premere una volta per verificare il livello di carica della batteria.
Premere e tenere premuto per accendere/spengere.

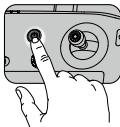

Basso —————> Alto



Premere una volta per verificare il livello di carica della batteria sullo schermo LCD.
Premere una volta, quindi premere e tenere premuto per accendere/spengere il dispositivo di controllo remoto.



Installa la batteria sul velivolo e accendila. Se la temperatura della batteria si abbassa sotto i 6°C, questa inizierà a riscaldarsi automaticamente per mantenere una temperatura tra 8 e 10°C. Consultare il manuale d'uso per maggiori informazioni.

4. Preparazione del dispositivo di controllo remoto



Sollevare le antenne



Rimuovere gli stick



Ruotare gli stick per fissarli

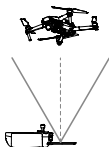
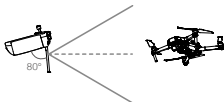
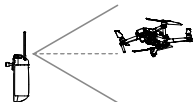

The optimal transmission range is shown above. Ensure the antennas are facing towards the aircraft. When the angle between the antennas and the back of the Smart Controller is 80° or 180°, the connection between the Smart Controller and the aircraft can reach its optimal performance.

The illustrations above show situations where the operator and aircraft are far away.



- Accertarsi che le levette di comando siano montate saldamente.
- Durante il reale funzionamento, l'app DJI Pilot si attiverà per avvertire che il segnale di trasmissione è debole, e sarà necessario regolare le antenne per garantire che il velivolo torni all'interno del campo di trasmissione ottimale.

5. Preparazione al decollo



Accendere il dispositivo di controllo remoto



Accendere il velivolo



Lanciare l'app DJI Pilot



Internet

Usare un account DJI per attivare il velivolo e il radiocomando DJI Smart. L'attivazione richiede una connessione a internet. Prima di attivare il velivolo in DJI Pilot, accendere il radiocomando DJI Smart e seguire le istruzioni per l'attivazione.



Impostare una password per il velivolo nell'app DJI Pilot, per assicurare un accesso sicuro e proteggere i vostri dati durante il volo.

6. Volo

Prima del decollo, assicurarsi che la barra di stato del velivolo nell'app DJI Pilot indichi "Ready to Go".

Ready to Go (GPS)

• Decollo e atterraggio manuali

Combinazione di comandi da levette per avviare/arrestare i motori.



Portare la levetta sinistra (lentamente) verso l'alto per il decollo



Portare la levetta sinistra (lentamente) verso il basso finché non si tocca il suolo
Tenere premuto alcuni secondi per arrestare i motori



Arrestare i motori durante il volo solo in situazioni di emergenza e allo scopo di ridurre il rischio di danni o lesioni. L'opzione di blocco dei motori è disponibile tra le impostazioni di DJI Pilot.

* Funzionamento del dispositivo di controllo remoto

La modalità predefinita di controllo di volo è "Mode 2". La levetta sinistra controlla l'altitudine e la direzione del velivolo, mentre la levetta destra ne controlla i movimenti in avanti, all'indietro, a sinistra e a destra. Il quadrante del gimbal controlla l'inclinazione della telecamera.

Levetta sinistra



Levetta destra

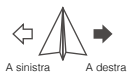

- Impostare sempre un'altitudine RTH adeguata prima del decollo. Quando il velivolo sta tornando al punto iniziale, è consigliabile guidarlo con le levette di comando.
- Premere il volo il pulsante Flight Pause per la frenata di emergenza durante il volo.

* Accessori modulari



Lampeggiante M2E



Riflettore M2E



Altoparlante M2E

7. Fly Safe



Volare in zone aperte

+



Segnale GPS forte

+



Mantenere la linea di visione

+



Volare a un'altitudine inferiore a 120 m (400 piedi)



Evitare di volare al di sopra o in prossimità di ostacoli, folle, linee elettriche ad alta tensione, alberi e specchi d'acqua.

NON utilizzare il velivolo in prossimità di intense sorgenti elettromagnetiche quali linee elettriche e stazioni di base, in quanto tali sorgenti possono influenzare la bussola di bordo.



NON utilizzare il velivolo in condizioni meteorologiche avverse come pioggia, neve, nebbia e venti con velocità superiore a 10 m/s (22 mph).



Mantenere la distanza dalle eliche rotanti e dai motori.



Zona interdetta al volo

Per saperne di più:
<http://fllysafe.dji.com/no-fly>



Per la sicurezza propria e delle altre persone presenti nelle vicinanze, è importante comprendere le linee guida di base del volo. Ricordare di leggere le **Limitazioni di responsabilità e le direttive sulla sicurezza**.

Caratteristiche tecniche

• Velivolo

Peso	899 g
Velocità massima	72 km/h (44,7 mph) in modalità Sport in assenza di vento

Quota massima di funzionamento sopra il livello del mare 6.000 m (19.685 piedi)

Temperatura di funzionamento Da -10 °C a 40 °C (da 14 °F a 104 °F)

GNSS GPS + GLONASS

Frequenza di funzionamento 2,4-2,4835 GHz; 5,725-5,850 GHz

Potenza del trasmettitore 2,4 GHz

(EIRP) FCC: ≤26 dBm; CE/MIC: ≤20 dBm; SRRC: ≤20 dBm

5,8 GHz

FCC: ≤26 dBm; CE: ≤14 dBm; SRRC: ≤26 dBm

24 GB

Memoria interna

• Gimbal

Intervallo controllabile Beccheggio: da -90° a +30°

• Termocamera

Sensore Microbolometro VOx non raffreddato

Obiettivo HFOV: 57°

Apertura: f/1.1

Interasse 12 μm

Banda spettrale 8-14 μm

Dimensione immagini 640×480 (4:3); 640×360 (16:9)

Modalità fotografica Scatto singolo

Scatto a raffica: 3/5/7 fotogrammi

Intervallo (2/3/5/7/10/15/20/30/60 s)

Modalità video 640×360 a 8.7 fps

Accuratezza Guadagno alto: max ± 5% (tipico)

Guadagno basso: max ± 10% (tipico)

Intervallo scena Guadagno alto: da -10 °C a +140 °C

Guadagno basso: da -10 °C a +400 °C

Foto JPEG

Video MP4, MOV (MPEG-4 AVC/H.264)

• Fotocamera ottica

Sensore CMOS da 1/2.3"; pixel effettivi: 12M

Obiettivo FOV: ca. 85°

Formato 35 mm equivalente: 24 mm

Apertura: f/2.8

Messa a fuoco: da 0,5 m a ∞

Intervallo ISO Video: 100-12800 (automatico)

Foto: 100-1600 (automatico)

Dimensioni dell'immagine (max.) 4056×3040 (4:3); 4056×2280 (16:9)

Modalità fotografica Scatto singolo

Scatto a raffica: 3/5/7 fotogrammi

Intervallo (2/3/5/7/10/15/20/30/60 s)

Modalità video 4K Ultra HD: 3840×2160 30p

2,7K: 2688×1512 30p

Full HD: 1920×1080 30p

Bit-rate massimo del video 100 Mbps

Foto JPEG

Video MP4, MOV (MPEG-4 AVC/H.264)

* Radiocomando DJI Smart

Batteria	5000mAh a 7,2V
Temperatura operativa	Tra -20° e 40° C
Capacità di memoria	ROM 16GB+scalabile (scheda microSD)
Ocusync 2.0	
Frequenza operativa	2.4-2.4835 GHz; 5.725-5.850 GHz
Distanza massima di trasmissione	FCC: 10 km; CE/MIC: 6 km; SRRC: 6 km (senza ostacoli e interferenze)
Potenza del trasmettitore (EIRP)	2.4 GHz FCC: ≤25.5 dBm; CE/MIC: ≤18.5 dBm; SRRC: ≤19 dBm 5.8 GHz FCC: ≤25.5 dBm; CE: ≤12.5 dBm; SRRC: ≤18.5 dBm

Wi-Fi

Protocollo	Wi-Fi Direct, Wi-Fi Display, 2x2 MIMO e 802.11a/g/n/ac
Frequenza operativa	2.4-2.4835 GHz; 5.150-5.250 GHz; 5.725-5.850 GHz
Potenza del trasmettitore (EIRP)	2.4 GHz FCC: ≤21.5 dBm; CE/SRRC: ≤18.5 dBm; MIC: ≤20.5 dBm 5.2 GHz FCC/CE/SRRC/MIC: ≤19 dBm 5.8 GHz FCC/SRRC: ≤21 dBm; CE:≤13 dBm

Bluetooth

Protocollo	Bluetooth 4.2
Frequenza operativa	2.4 – 2.48 GHz
Potenza del trasmettitore (EIRP)	≤4 dBm

* Caricabatterie

Tensione	17,6±0,1 V
Potenza nominale	60 W

* Batteria di volo intelligente

Capacità	3850 mAh
Tensione	17,6 V (max) 15,4 V (tipico)
Tipo di batteria	LiPo 4S
Energia	59,29 Wh
Peso netto	Circa 297 g
Intervallo temperatura di carica	Da 5 °C a 40 °C (da 41 °F a 104 °F)
Massima potenza di carica	80 W
Intervallo di temperatura per il riscaldamento automatico	da -20° a 6° C
Durata riscaldamento automatico	600 s (max)
Potenza riscaldamento automatico	35 W (max)

* Caricatore USB 24W

Ingresso	100-240 V~50/60 Hz (Max.) 0,8 A
Uscita	3,6-8 V = 3,0 A / 12 V = 2,0 A

※ Le normative locali in alcuni paesi proibiscono l'uso delle frequenze a 5.8 GHz e 5.2 GHz, e in alcune regioni la banda di frequenza a 5.2 GHz è consentita solo per uso interno.

Per ulteriori informazioni, consultare il Manuale utente:

www.dji.com/mavic-2-enterprise

※ Questi contenuti sono soggetti a modifiche senza preavviso.

MAVIC è un marchio registrato di DJI.

Copyright © 2020 DJI Tutti i diritti riservati.

Stampato in Cina.

Drone

De DJI™ MAVIC™ 2 Enterprise Dual heeft omnidirectionele Vision Systems en infraroodsensorsystemen*, en wordt geleverd met een volledig gestabiliseerde 3-assige gimbalcamera met een FLIR longwave infrarood thermische camera en een visuele camera, die zowel infrarood- als visuele beelden tegelijkertijd leveren. Kenmerkende DJI-technologieën zoals obstakeldetectie helpen u bij het moeiteloos nemen en vastleggen van complexe foto's. Extra functies zoals de geïntegreerde AirSense maken je bewust van het luchtruim om je heen, en de wachtwoordbeveiliging geeft je veilig toegang tot je drone en beschermt je gegevens. De Mavic 2 Enterprise heeft ook opzetbare modulaire accessoires zoals de M2-spotlight, het M2E-baken en de M2E-luidspreker, die speciaal zijn ontwikkeld voor verschillende toepassingen. De Mavic 2 Enterprise kan bogen op een maximale vliegsnelheid van 72 km/u (44,7 mph) en een maximale vliegtijd** van 31 minuten.

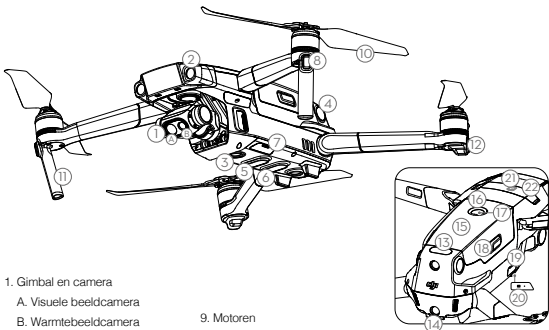

1. Gimbal en camera

- A. Visuele beeldcamera
- B. Warmtebeeldcamera

2. Vision System - naar voren

3. Vision System - naar beneden

4. Vision System - dwarsrichting

5. Naar beneden gericht infraroodsensorsysteem

6. Extra lampje onderaan

7. microSD-kaartsleuf

8. LED's voorzijde

9. Motoren

10. Propellers

11. Antennes

12. Statusindicator drone

13. Infraroodsensorsysteem

14. Vision System naar achteren

15. Intelligent Flight Battery

16. Accuniveau-LED's

17. Aan-/uitknop

18. Accuaansluitingen

19. USB-C-poort

20. Koppelhoeks/ koppingsstatusindicator

21. Uitbreidingspoort (voor het aansluiten van accessoires)

22. Afdekking uitbreidingspoort

* Het Vision System en infraroodsensorsysteem worden beïnvloed door omgevingsomstandigheden. Lees de disclaimer en veiligheidsrichtlijnen en de gebruikershandleiding en bekijk de instructiefilmpjes op de officiële DJI-website voor meer informatie. <http://www.dji.com/mavic-2-enterprise>

** De maximale vliegtijd is getest bij omstandigheden zonder wind en met een constante snelheid van 25 km/u (25,5 mph). Deze waarde geldt alleen ter referentie.

DJI Smart Controller

De DJI Smart Controller is een afstandsbediening gebouwd met de langeafstands-transmissietechnologie OCUSYNC™ 2.0 van DJI, die een maximaal zendbereik van 10 km biedt en een live HD-weergave geeft van de camera van het vliegtuig. De Smart Controller wordt geleverd met een aantal bedieningselementen voor vliegtuigen en gimbals en een aantal aanpasbare knoppen, en heeft een ingebouwd 5,5-inch scherm met hoge helderheid en meerdere functies zoals Bluetooth en GNSS. Verbinding met internet via wifi wordt ook ondersteund. De maximale gebruiksduur van de Smart Controller bedraagt 2.5 uur*.

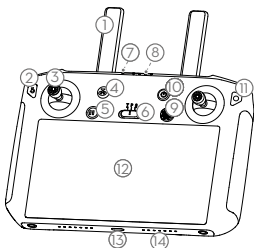

1. Antennes
2. Terugknop / Functieknop
3. Bedieningssticks
4. RTH-knop
5. Vluchtpauzeknop
6. Vluchtmodus-schakelaar
7. Status-LED
8. Accuniveau-LED's
9. 5D-knop
10. Aan-/uitknop
11. Bevestigingsknop / Aanpasbare knop C3
12. Aanraakscherm
13. USB-C-poort
14. Microfoon
15. Gimbal



16. Opnameknop
17. HDMI-poort
18. MicroSD-kaartsleuf
19. USB-A-poort
20. Scherpstellers- / Ontspanknop
21. Draaiknop instellingen sluiters / diafragma

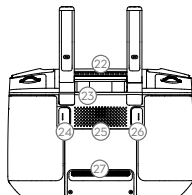

22. Ventilatieopening
23. Opslagplaats voor Bedieningssticks
24. Aanpasbare Knop C2
25. Luidspreker
26. Aanpasbare Knop C1
27. Luchtinlaat

* De Smart Controller kan de maximale overdrachtsafstand (FCC) bereiken in een grote open ruimte zonder elektromagnetische interferentie, en op een hoogte van circa 120 meter.

De maximale looptijd is getest in een laboratorium. Deze waarde geldt alleen ter referentie.

1. Bekijk de filmpjes met uitleg

Bekijk de instructiefilmpjes op www.dji.com/mavic-2-enterprise/info#video.



Filmpjes met uitleg

2. Drone voorbereiden

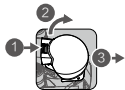

Verwijder de gimbal-afdekking van de camera.



Klap de voorarmen uit.



Klap de achterarmen uit.



Gemarkeerd Ongemarkeerd
Combineer de juiste propellers met de motoren.



Druk de propellers stevig naar beneden en draai ze in de vergrendelde stand.



Uitgeklapt



Klap de voorarmen en de propellers uit vóór de achterste. Alle armen en propellers moeten uitgeklapt zijn voordat mag worden opgestegen.

3. De accu's opladen

Gebruik de meegeleverde oplader om de Intelligent Battery volledig op te laden vóór het eerste gebruik.

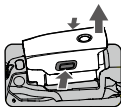

De Intelligent Flight Battery verwijderen

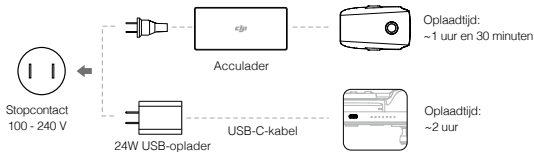

Gebruik alstublieft de officiële 24W USB-oplader om de Smart Controller op te laden. Wanneer een standaard 24W USB-oplader niet beschikbaar is, raden wij aan om een FCC/CE-gecertificeerde USB-oplader te gebruiken die geclassificeerd is als 12V/2A.

TN

* Controleer het laadniveau van de accu en de aan/uit-schakelaar

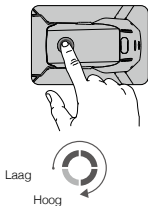

Druk eenmaal op de knop om het accuniveau te controleren.
Druk eenmaal en druk vervolgens opnieuw en houd vast om aan/uit te zetten.

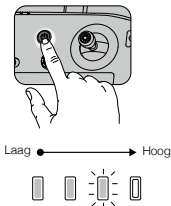

Druk eenmaal om het accuniveau op het LCD-scherm te controleren.
Druk eenmaal en druk vervolgens opnieuw en houd vast om de afstandsbediening aan/uit te zetten.



Plaats de accu in de drone en schakel de drone in. Wanneer de accutemperatuur lager wordt dan 6 °C, zal deze automatisch worden opgewarmd tot een temperatuur tussen 8-10 °C. Raadpleeg de gebruikershandleiding voor meer informatie.

4. Voorbereiding van de afstandsbediening

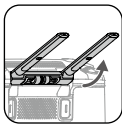

Til de antennes op



Verwijder de bedieningssticks



Roteer om de bedieningssticks te bevestigen

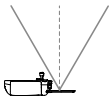
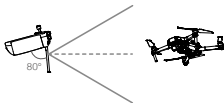
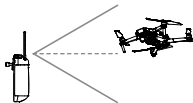

The optimal transmission range is shown above. Ensure the antennas are facing towards the aircraft. When the angle between the antennas and the back of the Smart Controller is 80° or 180°, the connection between the Smart Controller and the aircraft can reach its optimal performance.

The illustrations above show situations where the operator and aircraft are far away.



- Zorg dat de joysticks stevig zijn aangebracht.
- In de praktijk zal de DJI Pilot-app waarschuwen dat het transmissiesignaal zwak is, en dat de antennes aangepast dienen te worden om ervoor te zorgen dat het vliegtuig terugkeert naar het optimale transmissiebereik.

5. Voorbereiding voor opstijgen



Schakel de afstandsbediening in



Schakel het luchtvaartuig in



Start DJI Pilot



Internet

Gebruik een DJI-account om het vliegtuig en de Smart Controller te activeren. Activering vereist een internetverbinding. Zet de Smart Controller aan en volg de aanwijzingen voor het activeren voordat u het vliegtuig daadwerkelijk activeert in DJI Pilot.



Stel een wachtwoord in voor de drone in de DJI Pilot-app om veilige toegang te waarborgen en je boordgegevens te beschermen.

TN

6. Vlucht

Zorg er vóór het opstijgen voor dat de statusbalk van de drone in de DJI Pilot-app 'Ready to Go' aangeeft.

Ready to Go (GPS)

• Handmatig opstijgen/landen

Combination Stick Command (CSC) voor het starten/stoppen van de motoren



Linkerstick omhoog (langzaam) om op te stijgen



Linkerjoystick omlaag (langzaam) totdat u de grond raakt
Wacht enkele seconden om de motoren uit te schakelen



Schakel tijdens de vlucht de motoren alleen uit in noodsituaties, wanneer dit de kans op schade of letsel verkleint. De manier om de motor te stoppen kan worden ingesteld in DJI Pilot.

* Besturing met de afstandsbediening

De standaard vluchtregeling staat bekend als modus 2. Met de linkerjoystick regel je de hoogte en koers, terwijl je met de rechterjoystick vooruit, achteruit, naar links en rechts kunt bewegen. Met de gimbal regel je de kanteling van de camera.

Linkerjoystick



Omhoog



Omlaag



Linksaf



Rechtersaf

Rechterjoystick



Vooruit



Achteruit



Links



Rechts



- Stel altijd een passende RTH-hoogte in vóór het opstijgen. Als het luchtvaartuig terugkeert naar de basis, dien je het te begeleiden met de joysticks.
- Druk op de Flight Pause-knop om tijdens de vlucht een noodstop uit te voeren.

* Modulaire accessoires



M2E Baken



M2E Spotlicht



M2E Luidspreker

7. Vlieg veilig



Vlieg in open gebieden



Krachtig GPS-signaal



Houd je drone in het zicht



Vlieg lager dan 120 m (400 feet)



Vermijd vliegen boven of nabij obstakels, drukte, hoogspanningsleidingen, bomen of water.

Vlieg NIET in de buurt van sterke elektromagnetische bronnen zoals elektriciteitsleidingen en basisstations, daardoor kan het ingebouwde kompas ongunstig worden beïnvloed.



Gebruik de drone NIET bij ongunstige weersomstandigheden zoals regen, sneeuw, mist en bij windsnelheden van meer dan 10 m/s of 22 mph.



Blijf uit de buurt van de roterende propellers en motoren.



No-fly zone

Meer informatie vind je op: <http://fllysafe.dji.com/no-fly>



Het is belangrijk de basisvluchtrichtlijnen te begrijpen voor je veiligheid en die van je medemens. Vergeet niet de **disclaimer en veiligheidsrichtlijnen te lezen**.

Specificaties

• Drone

Gewicht	899 g
Max. snelheid	72 km/u (44,7 mph) in de sportmodus zonder wind
Max. servicehoogte boven zeeniveau	6000 m (19.685 ft)
Bedrijfstemperatuur	-10 °C tot 40 °C (14 °F tot 104 °F)
GNSS	GPS + GLONASS
Bedrijfsfrequentie	2,4-2,4835 GHz; 5,725-5,850 GHz
Zendervermogen (EIRP)	2,4 GHz FCC: ≤ 26 dBm; CE/MIC: ≤ 20 dBm; SRRC: ≤ 20 dBm 5,8 GHz FCC: ≤ 26 dBm; CE: ≤ 14 dBm; SRRC: ≤ 26 dBm
Interne opslag	24 GB

• Gimbal

Regelbaar bereik	Helling: -90° tot +30°
------------------	------------------------

• Warmtebeeldcamera

Sensor	Ongekoelde VOx-microbolometer
Lens	HFOV: 57° Diafragma: f/1,1
Pixelpitch	12 µm
Spectrale band	8-14 µm
Beeldgrootte	640 × 480 (4:3); 640 × 360 (16:9)
Fotografieermodi stilbeelden	Enkele opname Serie-opname: 3/5/7 beelden Interval (2/3/5/7/10/15/20/30/60 s) 640 × 360 @ 8,7 fps
Video-opnamemodi	Hoge gevoeligheid: Max ± 5% (standaard) Lage gevoeligheid: Max ± 10% (standaard)
Nauwkeurigheid	Hoge gevoeligheid: -10° tot +140°C Lage gevoeligheid: -10° tot +400°C
Scènebereik	JPEG
Foto	MP4, MOV (MPEG-4 AVC/H.264)
Video	

• Visuele beeldcamera

Sensor	1/2,3 inch CMOS, effectieve pixels: 12 M
Lens	Gezichtsveld: ca. 85° 35 mm-equivalent: 24 mm Diafragma: f/2,8 Focus: 0,5 m tot ∞
ISO-bereik	Video: 100 – 12800 (automatisch) Foto: 100 – 1600 (automatisch)
Maximale beeldgrootte	4056 × 3040 (4:3); 4056 × 2280 (16:9)
Fotografieermodi stilbeelden	Enkele opname Serie-opname: 3/5/7 beelden Interval (2/3/5/7/10/15/20/30/60 s)
Video-opnamemodi	4K Ultra HD: 3840 × 2160 30p 2,7K: 2688 × 1512 30p FHD: 1920 × 1080 30p
Max. videobitsnelheid	100 Mbps
Foto	JPEG
Video	MP4, MOV (MPEG-4 AVC/H.264)

* Smart Controller

Batterij	5000 mAh bij 7,2 V
Bedrijfstemperatuurbereik	-20 °C tot 40 °C
Opslagcapaciteit	ROM 16 GB + schaalbaar (microSD-kaart)
Ocusync 2.0	
Bedrijfsfrequentiebereik	2,4-2,4835 GHz; 5,725-5,850 GHz
Max. zendafstand	FCC: 10 km; CE/MIC: 6 km; SRRC: 6 km (Vrij van obstakels en interferentie)
Zendervermogen (EIRP)	2,4 GHz FCC: ≤25,5 dBm; CE/MIC: ≤18,5 dBm; SRRC: ≤19 dBm 5,8 GHz FCC: ≤25,5 dBm; CE: ≤12,5 dBm; SRRC: ≤18,5 dBm

Wifi

Protocol	Wifi Direct, Wifi-display, 2x2 MIMO en 802,11a/g/n/ac
Bedrijfsfrequentiebereik	2,4-2,4835 GHz; 5,150-5,250 GHz; 5,725-5,850 GHz
Zendervermogen (EIRP)	2,4 GHz FCC: ≤21,5 dBm; CE/SRRC: ≤18,5 dBm; MIC: ≤20,5 dBm 5,2 GHz FCC/CE/SRRC/MIC: ≤19 dBm 5,8 GHz FCC/SRRC: ≤21 dBm; CE:≤13 dBm

Bluetooth

Protocol	Bluetooth 4.2
Bedrijfsfrequentiebereik	2,4-2,4835 GHz
Zendervermogen (EIRP)	≤4 dBm

* Acculader

Spanning	17,6±0,1 V
Nominaal vermogen	60 W

* Intelligent Flight Battery

Capaciteit	3850 mAh
Spanning	17,6 V (max) 15,4 V (typisch)
Accutype	LiPo 4S
Vermogen	59,29 Wh
Netto gewicht	Ongeveer 297 g
Bereik oplaadtemperatuur	5 °C tot 40 °C (41 °F tot 104 °F)
Max. oplaadvermogen	80 W
Temperatuurbereik automatische verwarming	-20 °C tot 6 °C (-4 °F tot 43 °F)
Tijdsduur automatische verwarming	600 s. (max.)
Vermogen automatische verwarming	35 W (max.)

* 24W USB-oplader

Ingang	100-240 V ~ 50/60 Hz, max. 0,8 A
Uitgang	3,6-8 V = 3,0 A / 12 V = 2,0 A

※ Lokale voorschriften in sommige landen verbieden het gebruik van de 5,8 GHz- en 5,2 GHz-frequenties en in sommige regio's is de 5,2 GHz-frequentieband alleen toegestaan voor gebruik binnenshuis.

Lees de gebruikershandleiding voor meer informatie:

www.dji.com/mavic-2-enterprise

※ Deze inhoud is onderhevig aan wijzigingen zonder voorafgaande kennisgeving.

MAVIC is een handelsmerk van DJI.

Copyright © 2020 DJI Alle rechten voorbehouden.

Gedrukt in China.

Aeronave

O DJI™ MAVIC™ 2 Enterprise Dual apresenta Sistemas de Visão omnidirecional e Sistemas de Detecção de Infra-vermelhos* e vem equipado com uma câmara gimbal de 3 eixos totalmente estabilizada com uma câmara termográfica infravermelha de onda larga FLIR e uma câmara visual, fornecendo simultaneamente imagens de infravermelhos e visuais. As tecnologias de assinatura DJI, como a Detecção de Obstáculos, ajudam-no a voar e a captar imagens complexas sem esforço. Entre as funcionalidades adicionais, o AirSense incorporado permite que tenha uma maior perceção do espaço aéreo circundante, enquanto a proteção de palavra-passe o ajuda a manter o acesso seguro à aeronave e a proteger os seus dados. O Mavic 2 Enterprise também dispõe de acessórios modulares que podem ser facilmente fixados, como o Foco M2E, o Farol M2E e o Altifalante M2E, todos eles concebidos para várias aplicações. O Mavic 2 Enterprise conta com uma velocidade de voo máxima de 72 km/h (44,7 mi/h) e um tempo de voo máximo** de 31 minutos.

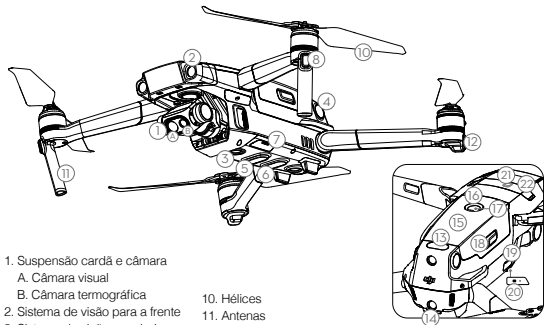

1. Suspensão cardã e câmara
 - A. Câmara visual
 - B. Câmara termográfica
2. Sistema de visão para a frente
3. Sistema de visão para baixo
4. Sistema de visão lateral
5. Sistema de deteção de infravermelhos para baixo
6. Luz auxiliar inferior
7. Ranhura para cartão microSD
8. LED frontais
9. Motores

10. Hélices
11. Antenas
12. Indicador de estado da aeronave
13. Sistema de deteção de infravermelhos para cima
14. Sistema de visão para trás
15. Bateria de voo inteligente
16. LED de nível da bateria
17. Botão de alimentação

18. Fivelas da bateria
19. Porta USB-C
20. Botão de ligação/Indicador de estado da ligação
21. Porta alargada (para ligar acessórios)
22. Tampa da porta alargada

* Os Sistemas de visão e os Sistemas de deteção de infravermelhos são afetados pelas condições ambiente. Consulte a Declaração de exoneração de responsabilidade, as Diretrizes de segurança e o Manual do utilizador e assista aos tutoriais de vídeo no Website oficial da DJI para saber mais.
<http://www.dji.com/mavic-2-enterprise>

** O tempo máximo de voo foi testado num ambiente sem vento e a uma velocidade de voo constante de 25 km/h (15,5 mi/h). Este valor serve meramente como referência.

DJI Smart Controller

O DJI Smart Controller é um controlador remoto construído com a tecnologia OCUSSYNC™ 2.0 de transmissão de longo alcance da DJI, oferecendo um alcance máximo de transmissão de 6.2 milhas (10 km) e oferece uma visualização HD ao vivo da câmara da aeronave. O Smart Controller vem com vários controlos de aeronaves e cardã, assim como botões personalizáveis e possui um ecrã de alto brilho de 5,5 polegadas incorporado com múltiplas funções, como Bluetooth e GNSS. A ligação à Internet via Wi-Fi também é suportada. O Smart Controller tem uma autonomia máxima de 2.5 horas*.

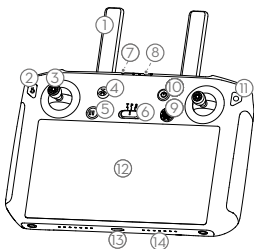

1. Antenas
2. Botão Voltar / Botão de Função
3. Manipulos
4. Botão RTH
5. Botão de pausa do voo
6. Interruptor de modo de voo
7. LED de estado
8. LED de nível da bateria
9. Botão 5D
10. Botão de alimentação
11. Botão de Confirmação / Botão Personalizável C3
12. Ecrã tátil
13. Porta USB-C
14. Microfone
15. Botão da suspensão cardã



16. Botão de gravação
17. Porta HDMI
18. Ranhura para cartão microSD
19. Porta USB-A
20. Botão de focagem / obturador
21. Seletor de ajuste de obturador/abertura

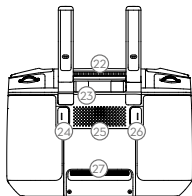

22. Saída de ar
23. Compartimento de armazenamento de manipululos
24. Botão C2 personalizável
25. Speaker
26. Botão C1 personalizável
27. Entrada de ar

* O Smart Controller consegue alcançar a sua distância máxima de transmissão (FCC) numa área ampla e aberta, sem interferência eletromagnética, a uma altitude de cerca de 120 metros (400 pés).

O tempo máximo de funcionamento é testado em ambiente de laboratório. Este valor serve meramente como referência.

1. Ver tutoriais em vídeo

Assista aos tutoriais de vídeo em www.dji.com/mavic-2-enterprise/info#video.



Vídeos tutoriais

2. Preparar a aeronave

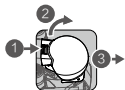

Retire a cobertura da suspensão cardã da câmara.



Desdobre os braços dianteiros.



Desdobre os braços traseiros.

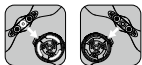

Com marcas Sem marcas

Faça corresponder as hélices aos motores.



Pressione as hélices firmemente para baixo e rode na direção de bloqueio.



Desdobrados



Desdobre os braços dianteiros e as hélices antes dos traseiros. Todos os braços e hélices têm de ser desdobrados antes de descolar.

3. Carregamento das baterias

Utilize o carregador fornecido para carregar completamente a bateria de voo inteligente antes da primeira utilização.

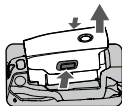

Remova a bateria de voo inteligente

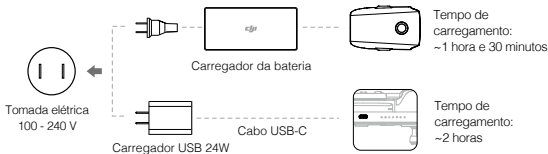

Use o carregador USB 24W oficial para carregar o Smart Controller. Quando um carregador USB 24W padrão não estiver disponível, recomenda-se usar um carregador USB com certificação FCC/CE classificado como 12V/2A.

*Verificar os níveis da bateria e ligar/desligar

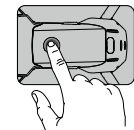

Prima uma vez para verificar o nível da bateria. Prima e, em seguida, prima e mantenha premido para ligar/desligar.

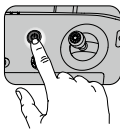

Prima uma vez para verificar o nível da bateria no ecrã LCD.

Prima uma vez e, em seguida, prima e mantenha premido para ligar/desligar o telecomando.



Instale a bateria na aeronave e ligue-a. Quando a temperatura da bateria for inferior a 6 °C, a mesma vai aquecer automaticamente para manter uma temperatura entre 8 e 10 °C. Consulte o Manual do utilizador para obter mais informações.

4. Preparar o telecomando

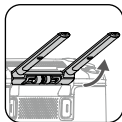

Levante as antenas



Remova os manipululos



Rode para prender os manipululos

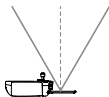
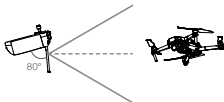
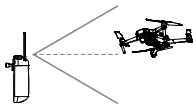

A faixa ótima de transmissão é mostrada acima. Certifique-se de que as antenas estão voltadas para a aeronave. Quando o ângulo entre as antenas e a parte posterior do Comando inteligente é de 80° ou 180° , a conexão entre o Comando inteligente e a aeronave pode atingir o seu desempenho ideal.

As ilustrações acima mostram situações em que o operador e a aeronave estão distantes.



- Certifique-se de que os manipululos de controle estão firmemente montados.
- Em operação real, a aplicação DJI Pilot avisa que o sinal de transmissão está fraco e ajuste as antenas para garantir que a aeronave esteja de volta à faixa ideal de transmissão.

5. Preparar a descolagem



Ligue o telecomando



Ligue a aeronave



Inicie a DJI Pilot



Internet

Use uma conta DJI para ativar a aeronave e o Smart Controller. A ativação requer uma ligação à Internet. Antes de ativar a aeronave no DJI Pilot, ligue o Smart Controller e siga as instruções para ativar.



Defina uma palavra-passe para a aeronave na aplicação DJI Pilot para garantir o acesso seguro à mesma e para proteger os seus dados a bordo.

6. Voo

Antes de descolar, assegure-se de que a barra de estado da aeronave na aplicação DJI Pilot indica "Ready to Go".

Ready to Go (GPS)

• Descolagem/Aterragem manual

Comando de manipuladores combinados para ligar/desligar os motores



OU



Desloque lentamente o manipulador esquerdo para cima para descolar



Desloque lentamente o manipulador esquerdo para baixo até que a aeronave toque no solo. Mantenha premido durante alguns segundos para parar os motores.



Pare os motores durante o voo apenas em situações de emergência, sempre que seja necessário fazê-lo para minimizar os riscos de danos ou ferimentos. O método para parar o motor pode ser definido no DJI Pilot.

* Operação do telecomando

O controlo de voo predefinido é conhecido como Modo 2. O manípulo esquerdo controla a altitude e o rumo da aeronave e o manípulo direito controla os movimentos para a frente, para trás, para a esquerda e para a direita. O botão da suspensão cardã controla a inclinação da câmara.

Manípulo esquerdo

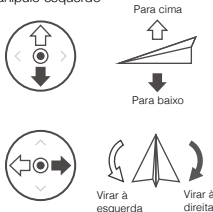

Manípulo direito

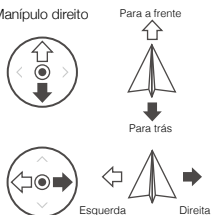

- Defina sempre uma altitude RTH adequada antes da decolagem. Quando a aeronave está a voltar ao ponto inicial, deverá dirigi-la com os manípulos de controlo.
- Prima o botão de pausa do voo para travagens de emergência durante o voo.

* Acessórios modulares



Farol M2E



Foco M2E



Altifalante M2E

7. Voar com segurança



Voar em áreas abertas

+



Sinal de GPS forte

+



Manter a linha de visão

+



Voar abaixo dos 120 m (400 pés)



Evite voar por cima ou perto de obstáculos, multidões, linhas elétricas de alta tensão, árvores e massas de água.

NÃO voe próximo de fontes eletromagnéticas fortes, tais como linhas de alta tensão e estações de rede móvel, pois estas podem afetar a bússola integrada.



NÃO utilize a aeronave em condições atmosféricas adversas, tais como chuva, neve, nevoeiro e ventos com velocidades superiores a 10 m/s ou 35,4 km/h.



Mantenha-se afastado das hélices e dos motores em rotação.



Zona de exclusão aérea

Saiba mais em:
<http://fllysafe.dji.com/no-fly>



É importante compreender as diretrizes básicas de voo para a segurança do utilizador e dos que o rodeiam. Não se esqueça de ler a **Declaração de exoneração de responsabilidade e as diretrizes de segurança**.

Características técnicas

• Aeronave

Peso	899 g
Velocidade máxima	72 km/h (44,7 mi/h) no modo desportivo sem vento
Limite de funcionamento máximo acima do nível do mar	6000 m (19 685 pés)
Temperatura de funcionamento	14 °F a 104 °F (-10 °C a 40 °C)
GNSS	GPS + GLONASS
Frequência de funcionamento	2,4 - 2,4835 GHz; 5,725 - 5,850 GHz
Potência do transmissor (EIRP)	2,4 GHz FCC: ≤26 dBm; CE/MIC: ≤20 dBm; SRRC: ≤20 dBm
	5,8 GHz FCC: ≤26 dBm; CE: ≤14 dBm; SRRC: ≤26 dBm
Armazenamento interno	24 GB

• Suspensão cardíaca

Amplitude controlável	Inclinação: -90° a +30°
-----------------------	-------------------------

• Câmara termográfica

Sensor	Microbolómetro VOx não refrigerado
Lente	HFOV: 57° Abertura: f/1.1

Distância entre píxeis	12 µm
Banda espectral	8-14 µm
Tamanho da imagem	640×480 (4:3); 640×360 (16:9)
Modos de fotografia estática	Disparo único Disparo contínuo: 3/5/7 fotogramas
	Intervalo (2/3/5/7/10/15/20/30/60 s)

Modos de gravação de vídeo	640×360 @8,7 fps
Precisão	Ganho elevado: Máx. ±5% (típico) Ganho baixo: Máx. ±10% (típico)
Intervalo da cena	Ganho elevado: -10 °C a +140 °C Ganho baixo: -10 °C a +400 °C

Fotografia	JPEG
Vídeo	MP4, MOV (MPEG-4 AVC/H.264)

• Câmara visual

Sensor	CMOS de 1/2,3", píxeis reais: 12M
Lente	FOV: aprox. 85° Equivalente ao formato de 35 mm: 24 mm Abertura: f/2.8

Gama ISO	Foco: 0,5 m para ∞ Vídeo: 100-12800 (automática) Fotografia: 100-1600 (automática)
Tamanho máximo da imagem	4056×3040 (4:3); 4056×2280 (16:9)
Modos de fotografia estática	disparo único

	Disparo contínuo: 3/5/7 fotogramas
	Intervalo (2/3/5/7/10/15/20/30/60 s)
Modos de gravação de vídeo	4K Ultra HD: 3840×2160 30p 2,7K: 2688×1512 30p FHD: 1920×1080 30p

Taxa máxima de bits de vídeo	100 Mbps
Fotografia	JPEG
Vídeo	MP4, MOV (MPEG-4 AVC/H.264)

*** Smart Controller**

Bateria	5000mAh a 7,2V
Intervalo de temperaturas de funcionamento	-4° a 104° F (-20° a 40° C)
Capacidade de armazenamento	ROM 16 GB + Escalonável (cartão microSD)
Ocusync 2.0	
Intervalo de frequências de funcionamento	2,4-2,4835 GHz; 5,725-5,850 GHz
Distância máxima de transmissão	FCC: 10 km; CE / MIC: 6 km; SRRC: 6 km (desobstruída, sem interferências)
Alimentação do transmissor (EIRP)	2,4 GHz FCC: ≤25,5 dBm; CE/MIC: ≤18,5 dBm; SRRC: ≤19 dBm 5,8 GHz FCC: ≤25,5 dBm; CE: ≤12,5 dBm; SRRC: ≤18,5 dBm

Wi-Fi

Protocolo	Wi-Fi Direct, WiFi Display, 2x2 MIMO, e 802.11a/g/n/ac
Intervalo de frequências de funcionamento	2,4-2,4835 GHz; 5,150-5,250 GHz; 5,725-5,850 GHz
Alimentação do transmissor (EIRP)	2,4 GHz FCC: ≤21,5 dBm; CE/SRRC: ≤18,5 dBm; MIC: ≤20,5 dBm 5,2 GHz FCC/CE/SRRC/MIC: ≤19 dBm 5,8 GHz FCC/SRRC: ≤21 dBm; CE: ≤13 dBm

Bluetooth

Protocolo	Bluetooth 4.2
Intervalo de frequências de funcionamento	2,4-2,4835 GHz
Alimentação do transmissor (EIRP)	≤4 dBm

*** Carregador da bateria**

Tensão	17,6 ± 0,1 V
Potência nominal	60 W

*** Bateria de voo inteligente**

Capacidade	3850 mAh
Tensão	17,6 V (máx.) 15,4 V (típico)
Tipo de bateria	LiPo 4S
Energia	59,29 Wh
Peso líquido	Aprox. 297 g
Intervalo de temperatura de carregamento	5 °C a 40 °C (41 °F a 104 °F)
Potência máx. de carregamento	80 W
Intervalo de temperatura de aquecimento automático	-20 a 6 °C (-4 a 43 °F)
Tempo de aquecimento automático	600 segundos (máx.)
Potência de aquecimento automático	35 W (máx.)

※ Os regulamentos locais em alguns países proíbem o uso das frequências de 5,8 GHz e 5,2 GHz e, em algumas regiões, a banda de frequência de 5,2 GHz só é permitida para uso interno.

Para mais informações, consulte o manual do utilizador:

www.dji.com/mavic-2-enterprise

※ Este conteúdo está sujeito a alterações sem aviso prévio.

MAVIC é uma marca comercial da DJI.

Copyright © 2020 DJI Todos os direitos reservados.

Impresso na China.

Aeronave

O DJI™ MAVIC™ 2 Enterprise Dual apresenta sistemas visuais omnidirecionais e de detecção por infravermelho*, contando com uma câmera com estabilizador triaxial totalmente estabilizado, uma câmera FLIR termográfica de infravermelho de ondas longas e uma câmera visual, fornecendo imagens por infravermelho e visuais simultaneamente. As tecnologias características da DJI, como o sensor de obstáculos, ajudam você a voar e capturar imagens complexas sem esforço. Recursos adicionais como o AirSense integrado fazem com que tome conhecimento do ambiente adjacente, e a proteção de senha permite que mantenha um acesso seguro à aeronave e proteja seus dados. O Mavic 2 Enterprise possui ainda acessórios modulares removíveis, como o Holofote M2E, o Farol M2E e o Alto-falante M2E, criados com o propósito de servir a múltiplos usos. O Mavic 2 Enterprise alcança uma velocidade máxima de voo de 72 km/h (44,7 mph) e um tempo de voo máximo** de 31 minutos.

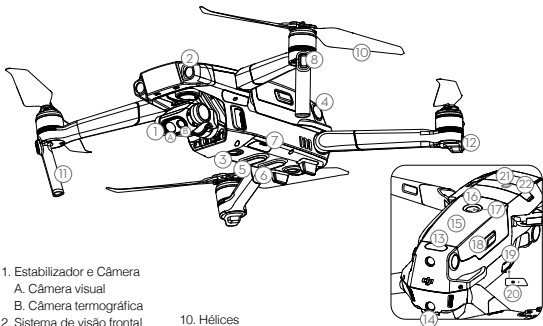

1. Estabilizador e Câmera
 - A. Câmera visual
 - B. Câmera termográfica
2. Sistema de visão frontal
3. Sistema de visão inferior
4. Sistema de visão lateral
5. Sistema de Detecção Infravermelho voltado para baixo
6. Luz inferior auxiliar
7. Slot de cartão microSD
8. LEDs dianteiros
9. Motores
10. Hélices
11. Antenas
12. Indicador de status da aeronave
13. Sistema de Detecção Infravermelho voltado para cima
14. Sistema de visão traseiro
15. Bateria de Voo Inteligente
16. LEDs de nível de bateria
17. Botão liga/desliga
18. Fivelas da bateria
19. Porta USB-C
20. Botão Link/Indicador de status da câmera
21. Porta de extensão (para acoplar acessórios)
22. Tampa da porta de extensão

* Os Vision Systems e os Sistemas de Detecção Infravermelho são afetados pelas condições circundantes. Leia a Isenção de Responsabilidade, as Diretrizes de Segurança, o Manual do Usuário e assista aos vídeos tutoriais no site oficial da DJI para saber mais. <http://www.dji.com/mavic-2-enterprise>

** O tempo de voo máximo foi testado em condição de vento zero à velocidade constante de 15,5 mph (25 km/h). Esse valor é meramente para referência.

Controle Inteligente DJI

O Controle Inteligente DJI é um controle remoto fabricado com a tecnologia de transmissão de longo alcance da DJI, OCUSYNC™ 2.0, oferecendo um alcance máximo de transmissão de até 10 km e concedendo visualização ao vivo em HD diretamente da câmera da aeronave. O Controle Inteligente vem equipado com múltiplos controles de aeronaves e estabilizadores, assim como botões personalizáveis, possuindo uma tela integrada de 5,5 polegadas com alta luminosidade e várias funções, como Bluetooth e GNSS. Conexão à internet através de Wi-Fi também é suportada. O Controle Inteligente possui um tempo máximo de funcionamento de 2.5 horas*.

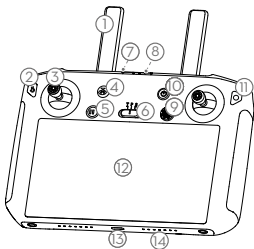

1. Antenas
2. Botão Voltar/Botão Função
3. Pinos
4. Botão RTH
5. Botão Pausa do voo
6. Interruptor Modo de voo
7. LED de status
8. LEDs de nível da bateria
9. Botão 5D
10. Botão Liga/Desliga
11. Botão Confirmar/botão Personalizável C3
12. Tela sensível ao toque
13. Porta USB-C
14. Microfone
15. Botão de rolagem do estabilizador

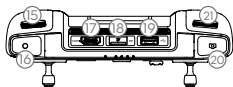

16. Botão de gravação
17. Porta HDMI
18. Entrada de cartão microSD
19. Porta USB-A
20. Botão Foco/Obturador
21. Abertura/botão de ajuste do obturador

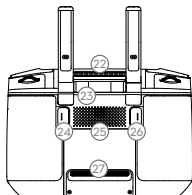

22. Saída de ar
23. Compartimento de armazenamento dos pinos
24. Botão Personalizável C2
25. Alto-falante
26. Botão Personalizável C1
27. Entrada de ar

* O Controle Inteligente é capaz de alcançar sua distância máxima de transmissão (FCC) em áreas ao ar livre sem interferência eletromagnética, a uma altitude de até cerca de 120 m.

O tempo de uso máximo é testado em um ambiente de laboratório. Esse valor é meramente para referência.

1. Assistindo aos vídeos tutoriais

Assista aos vídeos tutoriais em www.dji.com/mavic-2-enterprise/info#video.



Vídeos tutoriais

2. Preparo da aeronave

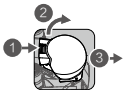

Remova o grampo do estabilizador da câmera.



Desdobre os braços frontais.



Desdobre os braços traseiros.

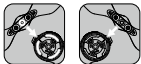

Corresponda as hélices aos motores.



Pressione as hélices firmemente para baixo e gire-a na direção de travamento.



Desdobrados



Desdobre os braços e as hélices frontais antes dos traseiros. Todos os braços e hélices devem ser desdobrados antes da decolagem.

3. Carga das baterias

Use o carregador fornecido para carregar totalmente a Bateria de Voo Inteligente antes de usar pela primeira vez.

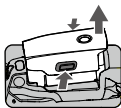

Remova a Bateria de Voo Inteligente

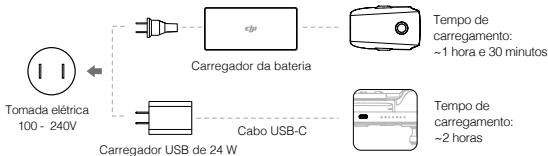

Favor utilizar o carregador USB de 24 W oficial para carregar o Controle Inteligente. Caso um carregador USB de 24 W padrão não esteja disponível, recomenda-se utilizar um carregador USB FCC/CE certificado com voltagem de 12 V/2 A.

* Verificação dos níveis da bateria e ligar/desligar

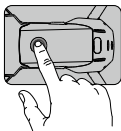

Pressione uma vez para verificar o nível da bateria.

Pressione uma vez; em seguida, novamente e segure para ligar/desligar.

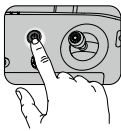

Baixo —————> Alto

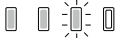

Pressione uma vez para verificar o nível da bateria na tela LCD.

Pressione uma vez e, em seguida, pressione e segure novamente para ligar/desligar o controle remoto.



Instale a bateria na aeronave e ligue-a. Uma vez que a temperatura da bateria for inferior a 6° C, entrará em aquecimento automático para manter uma temperatura entre 8° e 10° C. Confira o Manual do Usuário para obter mais detalhes.

4. Preparo do controle remoto



Levante as antenas



Remova os pinos



Gire para
encaixar os pinos

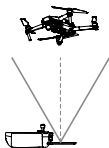
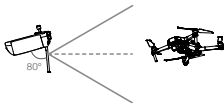
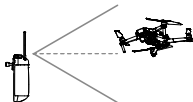

O alcance de transmissão ideal é exibido acima. Certifique-se de que as antenas estejam voltadas para a aeronave. Quando o ângulo entre as antenas e a parte posterior do Controle Inteligente for de 80° ou 180°, a conexão entre o Controle Inteligente e a aeronave poderá atingir seu desempenho ideal.

As ilustrações acima mostram situações nas quais o operador e a aeronave estão distantes.



- Confira se os joysticks estão colocados firmemente.
- Em ação, o aplicativo DJI Pilot avisará que o sinal de transmissão está fraco e pedirá para ajustar as antenas para garantir que a aeronave volte ao alcance de transmissão ideal.

5. Preparação para a decolagem



Ligue o controle remoto.



Ligue a aeronave.



Inicie o DJI Pilot



Internet

Use uma conta da DJI para ativar a aeronave e o Controle Inteligente. Ativar requer conexão com a internet. Antes de ativar a aeronave no DJI Pilot, ligue o Controle Inteligente e siga as instruções de ativação.



Defina uma senha para a aeronave no aplicativo DJI Pilot para garantir um acesso seguro e proteger seus dados a bordo.

6. Voo

Antes da decolagem, verifique se a barra de status da aeronave no aplicativo DJI Pilot exibe "Ready to Go".

Ready to Go (GPS)

* Decolagem e pouso manuais

Combination Stick Command para ligar/desligar os motores



Joystick esquerdo para cima (lentamente) para decolar



Mova (lentamente) o joystick para baixo até tocar o chão
Segure por alguns segundos para parar os motores



Para diminuir o risco de danos ou ferimentos, só interrompa os motores em pleno voo em caso de emergência. O método para interromper o motor pode ser configurado no aplicativo DJI Pilot.

* Operação do controle remoto

O padrão de controle de voo é conhecido como Modo 2. O joystick esquerdo controla a altitude e a direção da aeronave, enquanto o joystick direito controla os movimentos para frente, para trás, para a esquerda e para a direita. O botão giratório do gimbal controla a inclinação da câmera.

Joystick esquerdo



Para cima



Baixo



Virar à esquerda

Virar à direita

Joystick direito



Para frente



Para trás



Esquerda

Direita



- Configure sempre uma altitude RTH adequada antes de decolar. Quando a aeronave estiver retornando ao Home Point, você deverá orientá-la com os joysticks.
- Pressione o botão Flight Pause para pausas de emergência durante o voo.

* Acessórios modulares



Farol M2E



Holofote M2E



Alto-falante M2E

7. Voe com segurança



Voe em espaços abertos

+



Sinal de GPS forte

+



Mantenha o campo de visão

+



Voe abaixo de 120 m (400 pés)



Evite voar acima de ou próximo de obstáculos, multidões, linhas de alta tensão, árvores e corpos d'água.

NÃO voe próximo a fontes eletromagnéticas fortes, como linhas de energia e estações rádio base, pois isso pode afetar a bússola embarcada.



Não use a aeronave em condições climáticas adversas como chuva, neve, neblina e velocidades do vento acima de 10 m/s ou 22 mph.



Fique longe das hélices giratórias e dos motores.



Zona de exclusão aérea

Saiba mais em:
<http://fllysafe.dji.com/no-fly>



É importante que você compreenda as diretrizes básicas de voo, tanto para a sua proteção como para a segurança das pessoas à sua volta. Não se esqueça de ler a *isenção e as Diretrizes de segurança*.

Especificações

• Aeronave

Peso	899 g
Velocidade máx.	44,7 mph (72 km/h) no modo Sport, sem vento
Teto máximo de serviço acima do nível do mar	6.000 metros (19.685 pés)
Temperatura operacional	-10° a 40° C (14° a 104° F)
GNSS	GPS + GLONASS
Frequência de funcionamento	2,4 – 2,4835 GHz; 5,725 – 5,850 GHz
Potência do transmissor	2,4 GHz
(EIRP)	FCC: ≤ 26 dBm; CE/MIC: ≤ 20 dBm; SRRC: ≤ 20 dBm
	5,8 GHz
	FCC: ≤ 26 dBm; CE: ≤ 14 dBm; SRRC: ≤ 26 dBm
Armazenamento interno	24 GB

• Estabilizador

Amplitude controlável Inclinação: -90° a +30°

• Câmera termográfica

Sensor	Microbolômetro VOx não refrigerado
Lente	Ventilação oscilatória de alta frequência (HFOV): 57°
	Abertura: f/1.1
Densidade dos pixels	12 µm
Alcance espectral	8-14 µm
Dimensões da imagem	640×480 (4:3); 640×360 (16:9)
Modos de fotografia	Disparo único
	Disparo contínuo: 3/5/7 quadros
	Intervalo (2/3/5/7/10/15/20/30/60 s)

Modos de gravação de vídeo

Precisão	640×360 a 8,7 fps
	Alto ganho: Máx. ± 5% (típico)
	Baixo ganho: Máx. ± 10% (típico)
	Alto ganho: -10° a +140 °C
	Baixo ganho: -10 ° a +400 °C
	JPEG
	MP4, MOV (MPEG-4 AVC/H.264)

Alcance da cena

Foto	
Vídeo	

• Câmera visual

Sensor	CMOS de 1/2.3"; pixels efetivos: 12 M
Lente	Campo de visão: aprox. 85°
	Formato equivalente (35 mm): 24 mm
	Abertura: f/2.8
	Foco: 0,5 m até o ∞
Alcance ISO	Vídeo: 100-12800 (automático)
	Foto: 100-1600 (automático)
Dimensões máximas da imagem	4056×3040 (4:3); 4056×2280 (16:9)
Modos de fotografia	Disparo único
	Disparo contínuo: 3/5/7 quadros
	Intervalo (2/3/5/7/10/15/20/30/60 s)

Modos de gravação de vídeo

	4K Ultra HD: 3840×2160 30p
	2,7K: 2688×1512 30p
	FHD: 1920×1080 30p
Taxa de bits máx. do vídeo	100 Mbps
Foto	JPEG
Vídeo	MP4, MOV (MPEG-4 AVC/H.264)

*** Controle Inteligente**

Bateria	5000 mAh @ 7,2 V
Alcance da temperatura de funcionamento	-20° a 40 °C
Capacidade de armazenamento	ROM 16 GB + possibilidade de expansão (cartão microSD)
OcuSync 2.0	
Alcance da frequência de funcionamento	2,4-2,4835 GHz; 5,725-5,850 GHz
Distância máx. de transmissão	FCC: 10 km; CE/MIC: 6 km; SRRC: 6 km (Sem obstruções, livre de interferências)
Potência do transmissor (EIRP)	2,4 GHz FCC: ≤25,5 dBm; CE/MIC: ≤18,5 dBm; SRRC: ≤19 dBm 5,8 GHz FCC: ≤25,5 dBm; CE: ≤12,5 dBm; SRRC: ≤18,5 dBm

Wi-Fi

Protocolo	Wi-Fi Direct, Wi-Fi Display, 2x2 MIMO e 802.11a/g/n/ac
Alcance da frequência de funcionamento	2,4-2,4835 GHz; 5,150-5,250 GHz; 5,725-5,850 GHz
Potência do transmissor (EIRP)	2,4 GHz FCC: ≤21,5 dBm; CE/SRRC: ≤18,5 dBm; MIC: ≤20,5 dBm 5,2 GHz FCC/CE/SRRC/MIC: ≤19 dBm 5,8 GHz FCC/SRRC: ≤21 dBm; CE: ≤13 dBm

Bluetooth

Protocolo	Bluetooth 4.2
Alcance da frequência de funcionamento	2,4-2,4835 GHz
Potência do transmissor (EIRP)	≤4 dBm

*** Carregador da bateria**

Tensão	17,6±0,1 V
Potência nominal	60 W

*** Bateria de Voo Inteligente**

Capacidade	3850 mAh
Tensão	17,6 V (máx.), 15,4 V (típica)
Tipo de bateria	LiPo 4S
Energia	59,29 Wh
Peso líquido	Aprox. 297 g
Faixa de temperatura de carregamento	5° a 40° C (41° a 104° F)
Potência máx. de carga	80 W
Alcance da temperatura de aquecimento automático	-20° a 6 °C
Duração do aquecimento automático	600 s (máx.)
Carga do aquecimento automático	35 W (máx.)

*** Carregador USB de 24 W**

Entrada	100-240 V~50/60 Hz, Máx. 0,8 A
Saída	3,6-8 V = 3,0 A / 12 V = 2,0 A

※ Os regulamentos locais em alguns países proíbem o uso das frequências 5,8 GHz e 5,2 GHz e, em algumas regiões, a faixa de frequência 5,2 GHz só é permitida para uso interno.

Para mais informações, consulte o manual do usuário:

www.dji.com/mavic-2-enterprise

※ Este conteúdo está sujeito a alterações sem prévio aviso.

MAVIC é uma marca comercial da DJI.

Copyright © 2020 Todos os direitos reservados.

Impresso na China.

Дрон

DJI™ MAVIC™ 2 Enterprise Dual оснащен всенаправленными системами обзора и инфракрасными датчиками* а также полностью стабилизированной 3-осевой камерой с длинноволновой инфракрасной тепловизионной камерой FLIR и оптической камерой, благодаря которым можно получать инфракрасные и визуальные изображения одновременно. Такие фирменные технологии DJI, как система обнаружения препятствий упрощают съемку сложных сцен во время полета. Дополнительные функции, например, встроенная система AirSense, позволяют анализировать зону полета. Защита паролем обеспечивает безопасность доступа к летательному аппарату и данным. С Mavic 2 Enterprise также можно использовать дополнительные аксессуары: M2E Прожектор, M2E Сигнальный огонь и M2E Динамик. Максимальная скорость полета Mavic 2 Enterprise составляет 72 км/ч (44,7 мили/ч), а максимальное время полета** — 31 минута.

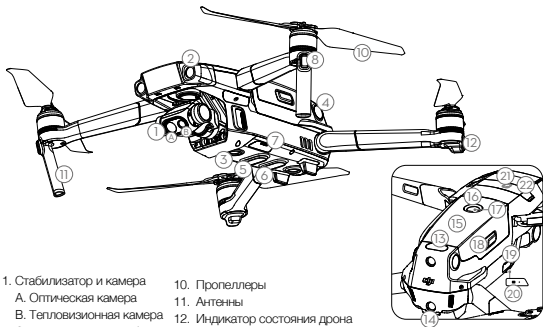

1. Стабилизатор и камера
 - A. Оптическая камера
 - B. Тепловизионная камера
2. Система переднего обзора
3. Система нижнего обзора
4. Система бокового обзора
5. Система нижних инфракрасных датчиков
6. Luz inferior auxiliar.
7. Слот для карты памяти microSD
8. Передние огни
9. Электродвигатели
10. Пропеллеры
11. Антенны
12. Индикатор состояния дрона
13. Система верхних инфракрасных датчиков
14. Система заднего обзора
15. Аккумулятор Intelligent Flight Battery
16. Светодиодные индикаторы уровня заряда аккумулятора
17. Кнопка питания
18. Зажимы крепления аккумулятора
19. Порт USB-C
20. Кнопка подключения/индикатор состояния подключения
21. Удлиненный порт (для подсоединения аксессуаров)
22. Удлиненная крышка для порта

* Работа систем обзора и систем инфракрасных датчиков зависит от условий окружающей среды. Для получения более подробной информации ознакомьтесь с заявлением об отказе от ответственности и руководством по технике безопасности, руководством пользователя и посмотрите обучающие видео на официальном сайте DJI. <http://www.dji.com/mavic-2-enterprise>

** Результат, полученный во время испытаний при полете в безветренных условиях с постоянной скоростью 25 км/ч (15,5 мили/ч). Данное значение приведено исключительно в справочных целях.

Пульт DJI Smart Controller

DJI Smart Controller – пульт дистанционного управления с встроенной технологией передачи сигнала на дальние расстояния DJI OCUSSYNC™ 2.0. Максимальное значение передачи сигнала HD с камеры летательного аппарата составляет 10 км. Интеллектуальный пульт позволяет управлять летательным аппаратом и стабилизатором. Он оснащен настраиваемыми кнопками, встроенным 5,5-дюймовым высокоярким дисплеем а также такими функциями как Bluetooth и спутниковые системы позиционирования. Также поддерживается подключение к интернету через Wi-Fi. Максимальное время работы интеллектуального пульта составляет 2,5 часа*.

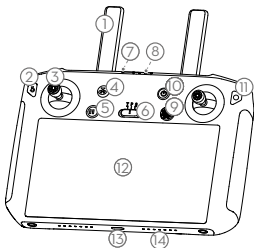

1. Антенны
2. Кнопка «Назад» / «Функция»
3. Джойстики
4. Кнопка возврата домой (RTH)
5. Кнопка остановки полета
6. Переключатель режимов полета
7. Светодиодный индикатор состояния
8. Светодиодные индикаторы уровня заряда аккумулятора
9. Кнопка 5D
10. Кнопка питания
11. Кнопка подтверждения / настраиваемая кнопка C3
12. Сенсорный экран
13. Порт USB-C
14. Микрофон
15. Колесико наклона камеры

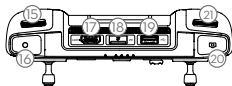

16. Кнопка записи
17. Порт HDMI
18. Слот для карты памяти microSD
19. Порт USB-A
20. Кнопка фокусировки / Кнопка спуска затвора
21. Регулятор диафрагмы/затвора

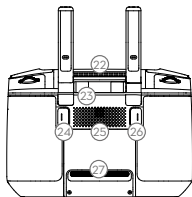

22. Вентиляционное отверстие
23. Слот для хранения джойстиков
24. Настраиваемая кнопка C2
25. Динамик
26. Настраиваемая кнопка C1
27. Воздухозаборник

* Пульт управления способен передавать сигнал на максимальное расстояние по стандарту FCC при соблюдении следующих условий: открытая местность без электро-магнитных помех, дрон летит на высоте 120 метров.

Максимальное время работы измерено в лабораторных условиях. Данное значение приведено исключительно в справочных целях.

1. Посмотрите видео-уроки

Обучающие видео на сайте: www.dji.com/mavic-2-enterprise/info#video.



Обучающие видеоролики

2. Подготовка дрона

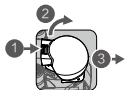

Снимите чехол стабилизатора с камеры.



Разложите передние лучи.



Разложите задние лучи.

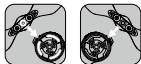

Соблюдайте цветовую кодировку пропеллеров и электродвигателей.



Надавите на пропеллер и поворачивайте в направлении блокировки.



Разложенное состояние



Всегда раскладываете сначала передние лучи, затем — задние. Все лучи и пропеллеры должны находиться в разложенном состоянии перед взлетом.

3. Зарядка аккумуляторов

Используйте предоставленное в комплекте зарядное устройство, чтобы полностью зарядить аккумулятор Intelligent Flight Battery перед первым использованием.

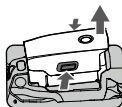

Снимите аккумулятор Intelligent Flight Battery



Используйте фирменное зарядное устройство USB на 24 Вт для зарядки интеллектуального пульта. Если фирменное зарядное устройство недоступно, рекомендуется использовать зарядное устройство USB, соответствующее стандарту FCC/CE, 12В/2А.

* Проверьте уровень заряда аккумуляторов и включите/выключите питание

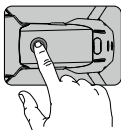

Нажмите один раз для проверки уровня заряда аккумулятора.
Нажмите один раз, затем нажмите и удерживайте для включения/выключения.

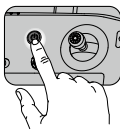

Низкий —————> Высокий



Нажмите один раз для проверки уровня заряда аккумулятора на ЖК-экране.
Нажмите один раз, затем нажмите и удерживайте для включения/выключения пульта дистанционного управления.



Установите аккумулятор в летательный аппарат и включите его. Если температура аккумулятора опустится ниже +6°C, он начнет нагреваться до достижения температуры +8...+10°C. Подробности см. в руководстве пользователя.

4. Подготовка пульта дистанционного управления к работе

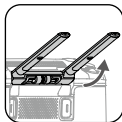

Поднимите антенны



Снимите джойстики



Поверните, чтобы установить джойстики

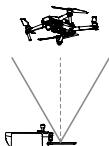
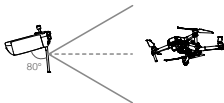
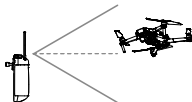

Оптимальная дальность передачи сигнала указана выше. Убедитесь, что антенны направлены на летательный аппарат. Соединение между интеллектуальным пультом и дроном будет считаться оптимальным, когда угол между антеннами и задней панелью пульта составляет 80° ... 180° .

На приведенных выше иллюстрациях показаны ситуации, когда пилот и летательный аппарат находятся на расстоянии.



- Убедитесь, что джойстики надежно закреплены.
- Если приложение DJI Pilot выдает предупреждение о том, что сигнал слабый, необходимо поменять положение антенн для достижения оптимального значения дальности передачи сигнала.

5. Подготовка к взлету



Включите пульт дистанционного управления



Включите дрон



Запустите DJI Pilot



Интернет

Для активации летательного аппарата и интеллектуального пульта используйте учетную запись DJI. Необходимо подключение к интернету. Перед активацией летательного аппарата в приложении DJI Pilot включите интеллектуальный пульт и следуйте пошаговой инструкции.



Установите пароль для дрона в приложении DJI Pilot, чтобы обеспечить защиту доступа данных.

6. Полет

Перед взлетом убедитесь, что в строке состояния дрона в приложении DJI Pilot показано Ready to Go (Полет разрешен).

Ready to Go (GPS)

RU

* Ручной взлет / посадка

Положение джойстиков для включения/выключения электродвигателей



ИЛИ



Плавное сдвигание левого джойстика вверх для взлета



Смещайте левый джойстик вниз (плавно), пока дрон не коснется поверхности. Для выключения двигателей удерживайте джойстик в нижнем положении в течение нескольких секунд.



Выключайте моторы во время полета только в экстренных ситуациях, в которых это может быть необходимо для предотвращения травм и опасных ситуаций. Способ выключения мотора может быть задан в приложении DJI Pilot.

* Эксплуатация пульта дистанционного управления

Режим 2 является режимом управления по умолчанию. Левый джойстик используется для управления высотой и поворотом дрона, правый — для управления движением вперед, назад, влево и вправо. Колесико стабилизатора управляет наклоном камеры.

Левый джойстик



Вверх



Вниз



Поворот
налево

Поворот
направо

Правый джойстик



Вперед



Назад



Влево

Вправо



- Перед взлетом всегда устанавливайте подходящую высоту для возврата домой. При возврате в исходную точку дрон необходимо направлять с помощью джойстиков.
- Нажмите на кнопку остановки режима полета для аварийного торможения во время полета.

RU

* Аксессуары



M2E Сигнальный огонь



M2E Проектор



M2E Динамик

7. Соблюдайте правила безопасности полетов



Выполняйте полеты на открытых участках

+



При сильном сигнале спутников

+



Выполняйте полет только в пределах прямой видимости

+



Выполняйте полет на высоте ниже 120 м (400 футов)



Следует избегать полетов над или в непосредственной близости от препятствий, скопления людей, высоковольтных линий электропередачи, деревьев и водоемов. ЗАПРЕЩАЕТСЯ выполнять полеты близко от таких источников сильного электромагнитного поля, как линии электропередачи и базовые станции, т. к. они могут влиять на работу встроенного компаса.



ЗАПРЕЩАЕТСЯ использовать дрон в неблагоприятных погодных условиях, таких как дождь, снег, туман и при скорости ветра более 10 м/с или 22 миль/ч.



Не приближайтесь к вращающимся пропеллерам и электродвигателям.



Зоны, запрещенные для полетов

Более подробная информация приведена на веб-сайте: <http://flysafe.dji.com/no-fly>



Для обеспечения своей безопасности и безопасности окружающих важно понимать основные принципы полета. Для получения дополнительной информации **обратитесь к отказу от ответственности и руководству по технике безопасности.**

Технические характеристики

* Дрон

Масса	899 г
Максимальная скорость	72 км/ч (44,7 мили/ч) в спортивном режиме в безветренную погоду
Максимальная высота полета над уровнем моря	6000 м (19 685 футов)
Диапазон рабочих температур	от -10 до 40 °C (от 14 до 104 °F)
GNSS	GPS + ГЛОНАСС
Рабочая частота	2,4-2,4835 ГГц
Мощность передатчика (ЭИИМ)	2,4 ГГц FCC: ≤26 дБм; CE/MIC: ≤20 дБм; SRRC: ≤20 дБм
Объем внутренней памяти	24 Гбайт

* Стабилизатор

Рабочий диапазон углов вращения	Наклон: от -90° до +30°
---------------------------------	-------------------------

* Тепловизионная камера

Матрица	Микроболометр на оксиде ванадия (VOx)
Объектив	Горизонтальный угол обзора: 57° Диафрагма: f/1.1
Шаг пикселя:	12 мкм
Спектральный диапазон	8–14 мкм
Размер изображения	640×480 (4:3); 640×360 (16:9)
Режимы фотосъемки	Покадровая съемка Серийная съемка: 3/5/7 кадров Интервальная (2/3/5/7/10/15/20/30/60 с)
Режимы видеосъемки	640×360 при 8,7 кадров/с
Точность	Высокая чувствительность: Макс. ± 5% (стандартное значение) Низкая чувствительность: Макс. ± 10% (стандартное значение)
Диапазон сцены	Высокая чувствительность: от -10° до +140°C Низкая чувствительность: от -10° до +400°C
Фото	JPEG
Видео	MP4, MOV (MPEG-4 AVC/H.264)

* Оптическая камера

Матрица	CMOS 1/2,3"; число эффективных пикселей: 12 млн
Объектив	Угол обзора: приближ. 85° 24 мм (эквивалент формата 35 мм) Диафрагма: f/2.8 Фокус: от 0,5 м до ∞
Диапазон ISO	Видео: 100–12800 (авто) Фото: 100–1600 (авто)
Максимальный размер изображения	4056×3040 (4:3); 4056 × 2280 (16:9)
Режимы фотосъемки	Покадровая съемка Серийная съемка: 3/5/7 кадров Интервальная (2/3/5/7/10/15/20/30/60 с)
Режимы видеосъемки	4K Ultra HD: 3840×2160 30p 2.7K: 2688×1512 30p FHD: 1920×1080 30p
Макс. битрейт видео	100 Мбит/с
Фото	JPEG
Видео	MP4, MOV (MPEG-4 AVC/H.264)

*** Пульт DJI Smart Controller**

Аккумулятор	5000 мАч при 7,2 В
Диапазон рабочих температур	-20°...+40°C
Объем памяти	ROM 16 Гб + по индивидуальному заказу (карта памяти microSD)

Ocusync 2.0

Диапазон рабочих частот	2,4–2,4835 ГГц
Макс. дальность передачи сигнала	FCC: 10 км; CE/MIC: 6 км; SRRC: 6 км (при отсутствии препятствий и помех)
Мощность передатчика (ЭИИМ)	2,4 ГГц FCC: ≤25,5 дБм; CE/MIC: ≤18,5 дБм; SRRC: ≤19 дБм

Wi-Fi

Протокол	Wi-Fi Direct, WiFi Display, 2x2 MIMO и 802.11a/g/n/ac
Диапазон рабочих частот	2,4–2,4835 ГГц
Мощность передатчика (ЭИИМ)	2,4 ГГц FCC: ≤21,5 дБм; CE/SRRC: ≤18,5 дБм; MIC: ≤20,5 дБм

Bluetooth

Протокол	Bluetooth 4.2
Диапазон рабочих частот	2,4–2,4835 ГГц
Мощность передатчика (ЭИИМ)	≤4 дБм

*** Зарядное устройство**

Напряжение	17,6±0,1 В
Номинальная мощность	60 Вт

*** Аккумулятор Intelligent Flight Battery**

Емкость	3850 мАч
Напряжение	17,6 В (макс.) 15,4 В (стандартн.)
Тип аккумулятора	Литий-полимерный 4S
Емкость	59,29 Вт·ч
Масса	Около 297 г
Диапазон температуры зарядки	от +5 до +40 °C (от 41 до 104 °F)
Максимальная мощность зарядки	80 Вт
Диапазон температур автоматического нагревания	-20°...+6°C
Время автоматического нагревания	600 с (макс.)
Мощность автоматического нагревания	35 Вт (макс.)

*** Зарядное устройство USB на 24 Вт**

Вход	100–240 В–50/60 Гц, макс. 0,8 А
Выход	3,6–8 В ⇄ 3,0 А/12 В ⇄ 2,0 А

Дополнительную информацию можно найти в руководстве пользователя:

www.dji.com/mavic-2-enterprise

※ Эта метка означает, что содержание может быть изменено без предварительного уведомления.

MAVIC является товарным знаком компании DJI.

© 2020 DJI Все права защищены.

Напечатано в Китае.

MAVIC 2 ENTERPRISE

Dual with Smart Controller



For online support,
please scan this code with
Facebook Messenger



微信扫一扫
获取技术支持



276DEPOS02SG