

MATRICE 600 SERIES

INTELLIGENT FLIGHT BATTERY Safety Guidelines

V1.0 2016.10

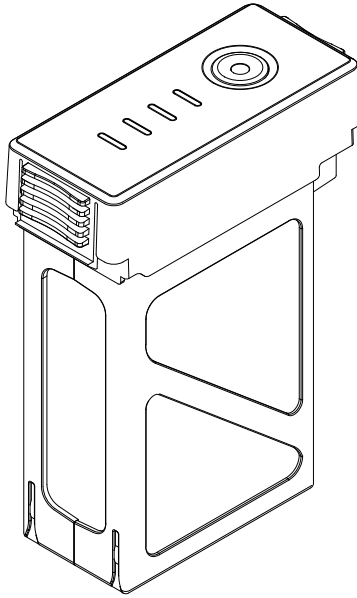

NOTICE

This document applies to the following models of Intelligent Flight Battery: TB47S and TB48S. All instructions and other collateral documents are subject to change at the sole discretion of SZ DJI TECHNOLOGY CO., LTD. For up-to-date product information, visit <http://www.dji.com> and click on the product page for this product.

Glossary

The following terms are used throughout the product literature to indicate various levels of potential harm when operating this product:

NOTICE NOTICE: Procedures, which if not properly followed, create a possibility of physical property damage AND possibility of injury.

CAUTION CAUTION: Procedures, which if not properly followed, create the probability of physical property damage AND possibility of serious injury.

WARNING WARNING: Procedures, which if not properly followed, create the probability of property damage, collateral damage, and serious injury OR create a high probability of superficial injury.



WARNING

Read the **ENTIRE** user manual to become familiar with the features of this product before operating. Failure to operate this product in a safe and responsible manner could result in injury or damage to the product or other property.

This is a sophisticated product. It must be operated with caution and common sense and requires some basic mechanical ability. This product is not intended for use by children without direct adult supervision. Do not use with incompatible components or alter this product in any way outside of the documents provided by SZ DJI TECHNOLOGY CO., LTD. These Safety Guidelines contain instructions for safety, operation and maintenance. It is essential to read and follow all of the instructions and warnings in the user manual, prior to assembly, setup or use, in order to operate the product correctly and avoid damage or serious injury.

Intelligent Flight Battery Safety Guidelines



WARNING

To avoid fire, serious injury, and property damage, observe the following safety guidelines when using, charging, or storing your batteries.

Battery Use

1. **DO NOT** allow the batteries to come into contact with any kind of liquid. **DO NOT** leave batteries out in the rain or near a source of moisture. **DO NOT** drop the battery into water. If the inside of the battery comes into contact with water, chemical decomposition may occur, potentially resulting in the battery catching on fire, and may even lead to an explosion.
2. Never use non-DJI batteries. Go to www.dji.com to purchase new batteries. DJI™ takes no responsibility for any damage caused by non-DJI batteries.
3. Never use or charge swollen, leaky, or damaged batteries. If your batteries are abnormal, contact DJI or a DJI authorized dealer for further assistance.
4. Battery must be fully charged before first-time use.
5. Never install or remove the battery from the aircraft when it is turned on. **DO NOT** insert or remove batteries if the plastic cover has been torn or compromised in any way.
6. The battery should be used in temperatures from -10° to 40° C. Use of the battery in environments above 50°C can lead to a fire or explosion. Use of battery below -10°C can lead to permanent damage.
7. **DO NOT** use the battery in strong electrostatic or electromagnetic environments. Otherwise, the battery control board may malfunction and cause a serious accident during flight.
8. Never disassemble or pierce the battery in any way or the battery may leak, catch fire, or explode.
9. Electrolytes in the battery are highly corrosive. If any electrolytes make contact with your skin or eyes, immediately wash the affected area with fresh running water for at least 15 minutes, and then see a doctor immediately.

10. DO NOT use the battery if it was involved in a crash or heavy impact.
11. If the battery falls into water with the aircraft during flight, take it out immediately and put it in a safe and open area. Maintain a safe distance from the battery until it is completely dry. Never use the battery again, and dispose of the battery properly as described in the Battery Disposal section below. DO NOT heat batteries. Put out any battery fire using sand or a dry powder fire extinguisher.
12. DO NOT connect the battery directly to a wall outlet or a car's cigarette lighter socket. Always connect the battery to the provided battery charger.
13. DO NOT throw the battery into a fire or expose to heat.
14. DO NOT use the battery if you notice abnormal odor, discoloration, deformation or anything unusual while using or storing it. If the battery is in use or being charged, remove it from the electrical appliance or battery charger immediately and dispose of it properly.
15. DO NOT put batteries in a microwave oven or in a pressurized container.
16. DO NOT place loose battery cells on any conductive surface, such as a metal table.
17. DO NOT put the loose cells in a pocket, bag or drawer where they may short-circuit against other items or where the battery terminals could be pressed against each other.
18. DO NOT drop or strike batteries. DO NOT place heavy objects on the batteries or charger. Avoid dropping batteries.
19. Clean battery terminals with a clean, dry cloth. When the terminals are dirty, unintended energy consumption or an inability to charge the battery may result.
20. DO NOT manually power on more than one Intelligent Flight Battery to avoid damaging the batteries. Powering on one of the six batteries will automatically trigger the others. If this fails, follow the instructions in the DJI GO™ app.

Battery Charging

1. Always use a DJI approved charger or charging hub. DJI takes no responsibility if the battery is charged using a non-DJI charger or charging hub.
2. Never leave the battery unattended during charging. DO NOT charge the battery near flammable materials or on flammable surfaces such as carpet or wood.
3. DO NOT charge the battery immediately after flight, because the battery temperature may be too high. DO NOT charge the battery until it cools down to near room temperature. Charging the battery outside of the temperature range of 5° to 40° C may lead to leakage, overheating, or battery damage.
4. Charge and discharge the battery completely once every 10 to 15 charge/discharge cycles. Discharge the battery until there is 0% power or until it can no longer be turned on, then recharge it to the maximum capacity. This power cycling procedure will optimize the battery life and help calibrate the battery gauge.
5. Disconnect the charger when not in use. Examine the charger regularly for damage to the plug, enclosure, or other parts. DO NOT clean the charger with denatured alcohol or other flammable solvents. Never use a damaged charger.

Battery Storage

1. Keep batteries out of the reach of children and pets.
2. DO NOT leave the battery near heat sources such as a furnace or heater. DO NOT leave the batteries inside of a vehicle on hot days. The ideal storage temperature is 22° to 28° C.
3. Keep the battery dry. Never drop the battery into water.
4. DO NOT drop, strike, impale, or manually short-circuit the battery.
5. Keep the battery away from metal objects such as glasses, watches, jewelry, and hairpins.
6. Never transport a damaged battery or a battery with power level higher than 50%.

Battery Disposal

1. Dispose of the battery in specific recycling boxes only after a complete discharge. DO NOT place the battery in regular trash containers. Strictly follow your local regulations regarding the disposal and recycling of batteries.

Battery Maintenance

1. Never charge a battery when environmental temperatures are too high or too low.
2. Never store a battery in environments with a temperature higher than 60°C.

Travel Notice

1. Before carrying the Intelligent Flight Battery onto an airplane, the battery must first be discharged to below 30%. This can be done by using your aircraft until the battery is depleted. Only discharge the battery in a fireproof location.

Factors that Reduce Battery Cell Life

1. **Over-discharging may damage the battery cells.**
2. **Battery cell temperature exceeds 70°C or falls below -10°C.**
3. **Battery is unused for extended periods.**
4. **Storage temperature exceeds 60°C.**

NOTICE

Battery Use

1. Make sure all the batteries are fully charged before each flight.
2. You must load all six battery compartments with batteries of the same model before each flight.
3. Land the aircraft immediately when the low battery level warning activates in the DJI GO app.

Battery Charging

1. The Intelligent Flight Battery is designed to stop charging when it is full. However it is a good practice to monitor the charging progress and disconnect the batteries when fully charged.

Battery Storage

1. Discharge the battery to 40-65% if it will NOT be used for 10 days or more. This can greatly extend the battery life.
2. The battery automatically discharges to below 65% when it is idle for more than 10 days to prevent it from swelling. You can change the idle time threshold in the DJI GO app. It takes approximately 3 days to discharge the battery to 65%. It is normal that you may feel moderate heat emitting from the battery during the discharge process. It is recommended to store the battery in a dedicated battery box.
3. The battery will enter hibernation mode if depleted and stored for a long period. Leave the battery unattended for 5 minutes, and then it will power off. Recharge the battery to bring it out of hibernation.
4. Remove batteries from the aircraft when stored for an extended period.
5. DO NOT store the battery for an extended period after fully discharging it. Doing so may over-discharge the battery and cause irreparable battery cell damage.

Battery Disposal

1. If the power on/off button on the Intelligent Flight Battery is disabled and the battery cannot be fully discharged, please contact a professional battery disposal/recycling agent for further assistance.
2. Battery should be properly disposed of when battery life drops to 0%.

Battery Maintenance

1. Never over-charge, as this may lead to battery cell damage.
2. Battery life may be reduced if not used for a long time.
3. Fully charge and discharge the battery at least once every 3 months to maintain battery health.

Travel Notice

1. Store Intelligent Flight Batteries in a ventilated location.

DJI Support
<http://www.dji.com/support>

This content is subject to change.

Download the latest version from
<http://www.dji.com/matrice600-pro>



If you have any questions about this document, please contact DJI by sending a message to DocSupport@dji.com.