

# X-PAD

ULTIMATE



# User's guide



X-PAD ULTIMATE



# X-PAD

U L T I M A T E

## User's guide

May 2019

© 2019 LSE S.r.l. – All rights reserved

---

## WARNING

In writing this manual every care has been taken to offer the most updated, correct and clear information possible; however unwanted errors are always possible and information can be subject to change. LSE S.r.l. cannot assume any liability resulting from the use of this manual and the same is true for every person or company involved in the creation, production or distribution of this manual. This manual is protected by copyright. Reproduction of this manual, even partial, in the absence of written authorization by LSE S.r.l. is prohibited by law.

---

## Trademarks

Google is a registered trademark of Google Inc.

Google Maps is a registered trademark of Google Inc.

Android is a registered trademark of Google Inc.

Bluetooth is a registered trademark of Bluetooth SIG, Inc.

AutoCAD is a registered trademark of AutoDesk Inc.

All other trademarks are trademarks of their respective owners.

---

# Index

<b>WARNING</b> .....	<b>4</b>
Trademarks .....	4
<b>Index</b> .....	<b>5</b>
<b>Introduction</b> .....	<b>23</b>
<b>Software installation, activation and first start.</b> .....	<b>25</b>
Installation procedure .....	25
Step 1 – Download X-PAD Ultimate Setup software .....	25
Step 2 – Install X-PAD Ultimate software .....	25
Step 3 – Run X-PAD Ultimate .....	25
Activation procedure .....	25
Adding other modules .....	27
On line activation modules .....	27
Off line activation modules .....	27
Information on license number and active modules .....	28
Installing localization packages .....	28
Automatic updates .....	31
Restoring a previous version .....	31
<b>Workspace</b> .....	<b>33</b>
Main window .....	33
Dialog boxes .....	33
Standard buttons .....	34
Weather forecast .....	35
Device information .....	35
Receiver/total station information .....	36
Virtual keyboard .....	36
Inserting latitude and longitude values .....	36
Inserting fractional feet .....	37
<b>Job managing</b> .....	<b>38</b>
Sites managing .....	38
Setting current site .....	38
Creating a new site .....	38
Deleting a site .....	38
Jobs managing .....	39

Visualization modes .....	39
Creating a new job .....	40
Opening an existing job .....	40
Opening a job saved on Cloud server .....	40
Properties of the job .....	41
Copying or sending a copy of the current job .....	41
Deleting a job .....	42
Rename a job .....	42
Compact and repair a job .....	42
Restoring a job.....	42
Job file .....	43
Conversion of X-PAD Survey 3 files.....	43
<b>Settings .....</b>	<b>44</b>
Units .....	44
Decimals .....	44
Coordinates.....	44
GNSS .....	44
Tab GNSS.....	44
Tab SURVEY .....	45
Tab STAKEOUT .....	47
Tab POINTS NAME.....	48
TPS .....	49
Tab TPS.....	49
Tab SURVEY .....	50
Tab STAKEOUT .....	51
Tab POINTS NAME.....	52
CAD .....	53
Tab Survey .....	53
Tab POINTS .....	53
Tab CAD.....	54
Laser scanner .....	54
X-Live .....	55
Miscellaneous .....	55
Miscellaneous .....	55
Localization settings.....	55
Automatic exporting .....	55
Voice commands .....	55

Android settings .....	56
Commands manager .....	56
X-Do!.....	56
Reports .....	56
Saving and loading settings .....	56
Save settings as default .....	56
Save setup as .....	57
Load settings.....	57
<b>Points, measures, survey codes and GIS features managing.....</b>	<b>58</b>
Topographic points.....	58
Creating a new point.....	58
Editing a point .....	59
Deleting a point.....	59
Visualizing point on CAD.....	59
Stakeout of a point.....	59
Sharing data of a point.....	59
Tools of the point page.....	59
Fieldbook of measures .....	63
Editing a measure.....	63
Change target/pole height .....	63
Deleting a measure .....	64
Restore deleted measure .....	64
Deleting a group of measures .....	64
Searching a measure.....	64
Visualizing notes.....	64
Adding a note .....	65
Moving GNSS base .....	65
Measures report.....	66
Create surface from bathymetry .....	66
Reference points .....	66
Survey codes .....	66
Creating a new code .....	67
Editing a code .....	68
Deleting a code.....	68
Deleting a group of codes.....	68
Creating a new library.....	68
Loading an existing library .....	69

Importing a list of codes from ASCII file .....	69
Importing a codes list from GeoMapper file .....	69
Importing a codes list from SCC file .....	70
Importing a codes list from LandXML file .....	70
Exporting current library .....	70
Exporting current library as default codes library .....	70
Managing GIS data .....	70
Symbols manager .....	70
Deleting a symbol .....	70
Importing new symbols .....	71
GIS features .....	71
Creating a new GIS feature .....	72
Adding a GIS attribute .....	72
Saving GIS features .....	73
Loading GIS features .....	73
<b>Coordinate system .....</b>	<b>74</b>
Cartographic system .....	74
Tools of cartographic system .....	74
Loading a predefined system .....	75
Saving a system as predefined .....	75
Deleting current cartographic system .....	75
GNSS localization .....	75
Local system – single point .....	76
Local system – Site calibration .....	76
Reference Axis .....	78
Cartographic system .....	78
Calculation of elevations .....	78
Tools of Coordinate System page .....	79
TPS coefficients .....	80
Base position adjustment .....	80
<b>CAD .....</b>	<b>82</b>
Closing CAD .....	82
Control of the visualization .....	82
How to set the working area .....	83
How to erase the working area .....	84
Display mode .....	84
3D View .....	84



Use of the maps .....	85
Select maps to visualize .....	85
WMS Maps (Web Map Server).....	85
Creating maps to use in off-line mode .....	85
Using off-line mode maps.....	86
Saving the current view as image .....	86
Augmented reality .....	86
GPS navigation mode.....	87
Project manager .....	87
Layers management.....	87
External reference.....	88
Surfaces.....	88
BIM items.....	89
CAD setup.....	89
Survey.....	89
Points .....	90
CAD.....	90
Importing DWG/DXF files.....	91
Exporting DXF files.....	91
Object snap .....	91
Working with object snap.....	92
Snap to topographic points .....	92
Drawing functions .....	92
Insert drawing coordinate .....	92
Drawing a layout .....	93
Drawing tools for BIM .....	96
Editing and creation of new points functions .....	97
Deleting objects.....	97
Distance intersection .....	97
Intersection.....	97
Distance e offset.....	97
Divide .....	98
Measure .....	98
Offset.....	98
Lengthen .....	98
Explode .....	99
Invert.....	99

Objects properties.....	99
Objects selection mode .....	99
Information commands .....	99
Coordinate of a point.....	99
Distance between two points .....	99
Distance point-object.....	100
Angle .....	100
Area .....	100
List .....	100
Report .....	101
Find topographic point .....	101
Longitudinal profile .....	101
Toolbar contextual – Points.....	101
Contextual toolbar – CAD objects .....	102
<b>Instruments settings .....</b>	<b>103</b>
Creation of a new GPS profile .....	104
Profile page.....	104
Device page .....	104
RTK page .....	104
RTK – Radio page.....	104
RTK – GPRS page .....	105
Parameters page .....	105
Antenna page .....	106
Managing of profiles of internet provider.....	106
Managing of profiles of servers of permanent stations (NTRIP) .....	106
Managing profiles of direct call.....	107
Management of Point-To-Point (PPP) profiles.....	107
Management of Dynamic DNS (DDNS) profiles .....	107
Creation of a profile using the GPS of the device .....	108
Creation of a new Total station profile .....	108
Profile page.....	108
Device page .....	109
Passive recordings.....	109
Editing a profile.....	109
Deleting a profile .....	109
Make current a profile .....	109
Reconfigure instruments .....	109

Creation of a new profile Laser Disto.....	110
Profile page.....	110
Device page .....	110
Parameters page .....	110
Creating a new Echosounder profile.....	110
Profile page.....	110
Device page .....	111
Creating a new profile Cable detector .....	111
Profile page.....	111
Device page .....	111
<b>GPS – GPS status .....</b>	<b>112</b>
Quality .....	112
Position.....	113
Skyplot.....	113
Satellites .....	113
Base .....	114
Map .....	114
Utility commands .....	114
Tools .....	114
Reset RTK correction.....	114
Activate/Deactivate use of constellations.....	114
Change cut-off angle.....	115
Connect/Disconnect GPRS.....	115
Change mountpoint .....	115
Reconfigure receiver .....	115
Editing GPS profile.....	115
File Manager .....	115
Stop raw data log .....	115
Change radio channel .....	116
Start output NMEA.....	116
GPS status panel .....	116
<b>GPS - Starting a base .....</b>	<b>118</b>
Starting a base on a known position.....	118
Starting a base on current position.....	119
Starting a base with previous settings .....	120
Start a base with Automatic (RTK position) settings .....	120
<b>Survey of points – GPS and TPS common functions.....</b>	<b>121</b>

TPS and GPS display mode.....	121
Using the maps.....	121
Augmented reality .....	123
Controller compass calibration .....	123
Electronic bubble.....	123
Activation of the electronic bubble .....	123
Calibration of the electronic bubble .....	124
Survey codes assignment.....	124
Manual insertion of code .....	124
Selection from table of the code .....	124
Edit a code during surveying .....	125
Quick codes.....	126
Selection of Quick codes.....	126
Customization of Quick codes.....	126
Add Quick-Codes page.....	127
Rename current page .....	127
Delete current page .....	127
GIS features.....	127
Smart Drawing – Drawing during survey .....	128
Single lines .....	128
Multiple lines.....	129
Average coordinates .....	132
Tools & utilities .....	132
Edit last point.....	133
Delete last point .....	133
Share last point.....	133
Adding a note .....	133
Points & measures .....	133
<b>X-Pole: one pole, two systems .....</b>	<b>134</b>
Using X-Pole in the station setup .....	134
Free station.....	134
Backsight point.....	135
Using X-Pole in site calibration .....	135
Using X-Pole during survey .....	136
Pole height .....	136
Research of the prism from GPS position.....	136
<b>GPS - Survey of points .....</b>	<b>137</b>

Survey of points .....	137
Rapid measuring of points .....	139
Measuring of points .....	139
Accuracy check .....	140
Measuring of points with GeoMax Zenith35 TAG .....	141
Hidden points .....	143
Measuring of hidden points by intersection of two distances .....	143
Measuring of hidden points by alignment and offset .....	145
Recording of raw data during survey .....	147
Automatic survey of points .....	147
Startup of the automatic measuring .....	149
Static survey .....	149
Starting occupation .....	149
Bathymetric survey .....	150
Start of the bathymetric survey .....	151
Setting the fixed route .....	151
Route setting from drawing element .....	152
Cancel route .....	152
Store points and measurements .....	152
Create surface .....	152
Add a note .....	152
Survey setup .....	152
Visualizing the survey sessions .....	153
Exporting the survey sessions .....	153
Survey with locators (cable detectors) .....	153
<b>GPS - Stakeout .....</b>	<b>154</b>
Stakeout information .....	154
Stakeout tolerance .....	156
Information referring to North or to Sun or to a reference point .....	156
Graphic and analytic view .....	157
Vocal information .....	157
How to interpret information provided .....	157
Common operations in Stakeout .....	157
Measuring the point .....	157
Stakeout parameters .....	158
Inserting a note .....	158
Points & Measurements .....	159

Reference surface .....	159
Automatic updating of the view .....	159
Stakeout of points .....	159
Stakeout of a list of points.....	160
Stakeout of coordinates ENZ.....	161
Stakeout of WGS84 coordinates .....	161
Stakeout of coordinates ECEF .....	161
Stakeout procedure .....	161
Stakeout of the next point.....	161
Stakeout of lines/arcs/objects.....	162
Stakeout of line by 2 points.....	162
Stakeout of arc by 3 points.....	162
Stakeout of arc by 2 points and radius .....	163
Stakeout of CAD element .....	163
Offset.....	163
Multiplier .....	163
Stakeout procedure .....	163
Stakeout of station & offset .....	164
Stakeout by offset referring to a line by 2 points .....	165
Stakeout by offset referring to an arc by 3 points.....	165
Stakeout by offset referring to an arc by 2 points and radius .....	165
Stakeout by offset referring to a CAD element.....	165
Offset parameters .....	165
Stakeout procedure .....	166
Stakeout of the next point by offset.....	166
Stakeout of sideslopes .....	166
Slopes.....	166
Stakeout procedure .....	167
Stakeout of surfaces.....	167
Stakeout report .....	168
<b>TPS - Controlling the total station .....</b>	<b>169</b>
Mechanic total station control panel.....	169
Control panel of robotic total station .....	169
Robotic page.....	170
Rotation page .....	171
Joystick page.....	172
Definition of the research area of fixed targets.....	173

Setting the environmental parameters (temperature, pressure, refraction / sphericity) .....	174
Search fixed targets .....	174
Settings of type of target .....	174
Favorite prisms .....	175
Constants of targets .....	175
Strategy of prism research.....	176
Use controller's GNSS .....	176
<b>TPS - Basic .....</b>	<b>177</b>
Main commands .....	177
<b>TPS – Station setup .....</b>	<b>179</b>
Using previous setup.....	179
Using the orientation of another job .....	179
Loading the orientation stored in the station .....	179
Select point for station setup .....	179
Instrument height calculation mode.....	180
Calculate instrument height from slant height .....	180
Calculate instrument height from keyboard height .....	180
Calculate instrument height from reference point.....	181
New orientation .....	181
New orientation to known position .....	182
Orientation to known point.....	182
Orientation by Azimuth .....	183
Orientation to multi points.....	184
New orientation with a position has to be calculated.....	184
Free station.....	185
Free station 3D .....	187
Auto Free station.....	187
Reference axis .....	187
2 reference axes .....	188
Batter boards.....	188
No orientation .....	189
Check orientation .....	190
Changing the height of the station .....	190
Reset the station elevation.....	190
Setting of elevation of the station from reference point .....	190
Set elevation from a single point .....	190
Set elevation from multi points .....	190

<b>TPS - Survey of points.....</b>	<b>192</b>
TPS display mode.....	194
Automatic updating of the view .....	194
Rapid measuring of points .....	194
Measuring of points .....	194
Measuring traverse points.....	195
Measuring of points by offset horizontal angle .....	196
Measuring of points by offset vertical angle .....	196
Measuring of points by offset in distance .....	196
Measuring of points on face 1 and face 2 .....	196
Measuring of points only with angle.....	197
Multi target pole.....	197
Setting the pole parameters.....	197
Measure of the targets .....	197
<b>TPS - STAKEOUT .....</b>	<b>198</b>
Stakeout information .....	198
Stakeout tolerance.....	200
Information referring to Target, to total station, to North or to a reference point.....	200
Graphic and analytic view.....	200
Vocal information.....	200
Common operations in stakeout.....	201
Measuring the point .....	201
Stakeout parameters .....	201
Turn toward point.....	202
Insertion of a Note .....	202
Point & measurement.....	202
Show up/down target buttons.....	202
Stakeout of points .....	203
Stakeout of a list of points.....	203
Stakeout of coordinates ENZ.....	204
Stakeout procedure .....	204
Stakeout of next point .....	204
Stakeout of lines/arcs/objects.....	205
Stakeout of line by 2 points.....	205
Stakeout of arc by 3 points.....	205
Stakeout of arc by 2 points and radius .....	206
Stakeout of CAD element .....	206



Offset.....	206
Multiplier .....	206
Stakeout procedure .....	206
Stakeout of station & offset .....	207
Stakeout by offset referring to a line by 2 points .....	208
Stakeout by offset referring to an arc by 3 points .....	208
Stakeout by offset referring to an arc by 2 points and radius .....	208
Stakeout by offset referring to a drawing element .....	208
Offset parameters .....	208
Stakeout procedure .....	209
Stakeout of the next point by offset.....	209
Sideslope stakeout .....	209
Slopes .....	210
Stakeout procedure .....	210
Stakeout of surfaces.....	210
Stakeout of BIM surface.....	211
Stakeout report .....	211
<b>TPS – Auto Measuring .....</b>	<b>212</b>
Auto Measuring flow.....	212
Control points .....	212
Inserting a new check point .....	212
Edit a check point.....	213
Points to measure .....	213
Insert a new point to measure.....	214
Edit a point to measure .....	214
Station orientation .....	214
Orientation mode.....	214
Station Data .....	214
Measuring reference points .....	215
Automatic Measurement.....	215
Single Measuring (manual) .....	216
Report.....	216
Report Points .....	216
Report sessions .....	217
Exporting and sharing Report.....	217
Activity log .....	217
Settings.....	218

<b>PicPoint – Measuring on photo .....</b>	<b>221</b>
Acquiring photo and position .....	221
Camera connection .....	221
Measuring procedure .....	221
Measuring on photos .....	222
New points creation .....	223
Distances measuring .....	223
Visualization options .....	223
Measure options .....	223
PicPoint from the measures fieldbook .....	224
<b>COGO .....</b>	<b>225</b>
Distances .....	225
Distance referring to a point .....	225
Distance referring to a line by 2 points .....	226
Distance referring to an arc by 3 points .....	226
Distance referring to an arc by 2 points and radius .....	227
Distance referring to a CAD element .....	227
Reference line .....	228
Line by 2 points .....	228
Arc by 3 points .....	228
Arc by 2 points and radius .....	229
CAD element .....	229
Offset .....	229
Reference line .....	229
Distance & Offset .....	230
Intersection .....	232
Intersection Double distance .....	232
Intersection Distance and azimuth .....	233
Intersection double azimuth .....	233
Intersection 4 points .....	234
Area subdivision .....	235
Area & Length .....	236
Check planes .....	236
Control of elevations on horizontal level .....	237
Control of elevations on vertical level .....	237
Control of elevation on level with one slope. ....	237
Control of elevation on level with two slopes .....	238

Control of elevation on level by three points .....	238
Display of elevation controls .....	238
Move, Rotate & Scale.....	239
Manual entry .....	239
Matching points .....	240
<b>Volumes and surfaces .....</b>	<b>242</b>
Surfaces.....	242
Creating a surface .....	242
Surfaces editing .....	243
Visualization of surface on Google Map.....	244
Visualization of surface in 3D .....	244
Surface visualization parameters.....	244
Deleting a surface.....	245
Performing the stakeout of a surface .....	245
Surfaces importing .....	245
Viewing the surfaces in the CAD .....	245
Volume calculation.....	245
Volume referring to a reference elevation .....	246
Volume referring to a reference point .....	246
Volume of a stockpile/pit .....	246
Volume referring to a reference plane .....	246
Calculation parameters.....	247
Viewing calculated data.....	247
Deleting a calculated volume .....	248
<b>Roading – roads stakeout.....</b>	<b>249</b>
Road manager.....	249
Importing road project from LandXML format .....	249
Importing road axis from DXF file .....	249
Transformation of a polyline into a road axis or side polyline .....	250
Importing road project from local format .....	250
Editing a road axis .....	250
Deleting a road axis.....	252
Stakeout .....	252
Sideslope stakeout .....	253
Slopes.....	253
Stakeout procedure .....	253
Where am I ?.....	253

X-Sections Templates .....	254
Adding a section model .....	254
Editing a section model .....	255
Deleting a section model .....	255
Stakeout report .....	255
<b>X-Live – Collaborative survey .....</b>	<b>256</b>
Creating an X-Live connection .....	256
Connecting to an X-Live connection.....	256
Disconnecting from an X-Live connection .....	256
Using the Chat .....	256
Sending messages .....	257
Sharing files .....	257
Sending points with X-Live.....	257
Coordinates systems sending with X-Live.....	257
Sharing points measured in real time .....	258
Settings.....	258
Options.....	258
Export options .....	259
Cloud-server options.....	259
<b>External references .....</b>	<b>260</b>
Adding an external reference .....	260
Importing an AutoCAD DXF file or an X-PAD job .....	260
Import an IFC file (Industries Foundation Classes) .....	261
Importing a raster image .....	261
Deleting an external reference.....	261
Loading external reference data .....	261
Downloading data of an external reference.....	261
Changing visibility status of an external reference .....	262
Reconnecting an external reference .....	262
<b>Data import.....</b>	<b>262</b>
Importing from file in AutoCAD DXF/DWG format .....	262
Importing from file in ASCII format .....	263
Importing from files in GSI format .....	264
Importing from files in LandXML format .....	264
Importing from files in ESRI Shape format .....	264
Importing from file in Trimble DC format.....	264
Importing a raster map .....	265

Importing from file in SurvCE RW5 format.....	265
Importing from file in Sokkia SDR format.....	265
<b>Export &amp; share data .....</b>	<b>266</b>
Exporting on file in X-PAD Office Fusion format .....	266
Exporting on file in AutoCAD DXF format .....	266
Exporting on file in ASCII format .....	267
Exporting on file in GSI format .....	268
Exporting on file in LandXML format .....	269
Exporting on file in Google Earth KML/KMZ format .....	269
Exporting on file in Garmin GPX format .....	269
Exporting on file in ESRI Shape file format .....	269
Exporting on file in Leica IDX/IDEX format .....	270
Exporting on file in Sokkia SDR format .....	270
Exporting on file in SurvCE RW5 format .....	270
Exporting on file in STAR*NET format .....	270
Exporting measures.....	270
Exporting in other formats .....	270





# Introduction

Thank you for purchasing **X-PAD Survey Ultimate!**

This guide will allow you to get all the information you need to use your **X•PAD** quickly and efficiently in all situations.

**X•PAD** functions are organized in modules that cover the different needs of users. Modularity is the following:

Modules	Description	Survey	Build
<b>GPS</b>	Main module inside which you find all basic functions for surveying and Stakeout with GPS.		
<b>TPS</b>	Main module inside which you find all basic functions for surveying and Stakeout with total station.		
<b>ROBOTIC</b>	Add-on module allowing to use robotic and motorized total stations. Requests presence of the TPS module.		
<b>X-POLE</b>	Add-on module that enables the simultaneous use of the GPS receiver and the total station.		
<b>GIS</b>	Add-on module for GIS data surveying; as well as the position of the point, the software allows to record other properties freely definable by the user.		
<b>VOLUME</b>	Add-on module for surfaces stakeout, volumes and surfaces calculation.		
<b>ROADING</b>	Allows the importing of road projecting data from different formats and stakeout of every element of the track according to different modes.		
<b>AUTO MEASURING GPS</b>	Add-on module for automatic measurement with GPS equipment.		
<b>AUTO MEASURING TPS</b>	Add-on module for automatic measurement with motorized total station.		
<b>BATHYMETRY</b>	Allows management of bathymetric surveys through acquisition of depth data from depth sounder and GPS position. Includes a route control.		
<b>LOCATORS</b>	Allows connection to utilities detectors and to record depth in correspondence to GPS positions.		
<b>PICPOINT</b>	Allows acquisition and processing of photo to allow measuring of points directly on it.		

<p><b>BIM</b></p>	<p>It allows the use of files in IFC format, includes various tools for using BIM data in the survey and stakeout phase.</p>		
<p><b>BUILD EXTENSION</b></p>	<p>Additional Module that includes the X-Pad Ultimate Build features.</p>		

In the command's description it's reported the logo of the corresponding module.



---

## Software installation, activation and first start.

To install the software in the device it's necessary to have the following files:







File	Description
it.geomax.xpad3.apk	Installation (setup) file
XPAD_*_Pack.lpk	Localization file corresponding to your country (optional)

---

### Installation procedure

#### Step 1 – Download X-PAD Ultimate Setup software

Download X-PAD Ultimate software from the links below:

Setup files		
	X-PAD Ultimate Survey	
	X-PAD Ultimate Build	
	X-PAD Ultimate - Release notes	

#### Step 2 – Install X-PAD Ultimate software

- If you need to activate **X-PAD Ultimate Survey** copy the file **it.geomax.xpadsurveyultimate.apk** file from PC to the controller and install it directly from the controller
- If you need to activate **X-PAD Ultimate Build** copy the file **it.geomax.xpadbuildultimate.apk** file from PC to the controller and install it directly from the controller
- If you need to activate **X-PAD Ultimate GO** copy the file **it.geomax.xpadbuildultimate.apk** file from PC to the controller and install it directly from the controller

#### Step 3 – Run X-PAD Ultimate

- From controller select **Applications** item

- Select  **X-PAD Survey Ultimate** icon or select  **X-PAD Build Ultimate** or select  **X-PAD Ultimate Survey GO**; X-PAD Ultimate will start.

---

### Activation procedure

At first run it's necessary to proceed with **X-PAD** activation. Two software activation modes are available.

### On-line activation (Internet connection required)

Step	Description
1	Select <b>On-line (internet)</b> option; device must be connected to Internet.
2	Insert <b>EquipmentID</b> and <b>Serial number</b> .
3	The activation will be executed automatically and you are ready to start.

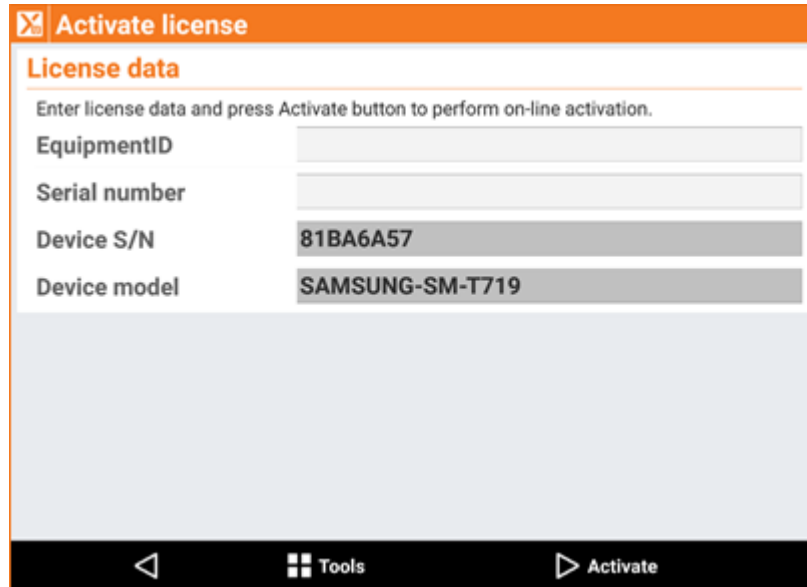

### Off-line activation

Step	Description
1	Select <b>Off-line</b> option
2	Link to the following URL: <a href="http://www.lse-license.com/xpadultimate">http://www.lse-license.com/xpadultimate</a>
3	Enter <b>EquipmentID</b> e <b>Serial number</b> .
4	Load <b>HOSTID</b> file.
5	Press <b>ACTIVATE</b> the <b>LICENSE</b> file can be immediately downloaded from the web page or will be available in the Download folder of the PC.
6	Copy the file <b>LICENSE</b> Controller in the controller's root folder and press <b>Activate</b> in <b>Xpad Ultimate</b> .





## X-PAD Ultimate - New license activation

EquipmentID:

Serial number:

HostID:

Device model:

Device serial:

Copyright © 2009-2018 LSE S.r.l. - Software Builders.  
All rights reserved. C.F. e P.IVA IT01650750936



Part of





## Adding other modules

It's possible to add other modules to current configuration.

### On line activation modules

Step	Description
1	Run X-PAD 
2	Click on X-PAD icon on top left 
3	Select <b>License &amp; Modules</b> page.
4	Hit <b>Update license</b> button. The correct license will be updated with new purchased modules.

### Off line activation modules

Step	Description
1	Run X-PAD 
2	Click on X-PAD icon on top left 
3	Select <b>License &amp; Modules</b> page.
4	Hit <b>Update license</b> button. Hit <b>OK</b> In the program message that warns you that you cannot request activation of the license.
5	From the browser open this URL <a href="http://www.lse-license.com/spadultimate">http://www.lse-license.com/spadultimate</a>
6	Select <b>UPDATE LICENSE</b> .
7	Enter your <b>EqiomentID</b> and press <b>Activate</b> .

8	Copy the <b>License</b> file from <b>Download</b> folder into the main folder of the device.
9	Press <b>Update</b> button from the device.

---

## Information on license number and active modules

Step	Description
1	Click on <b>X-PAD</b> icon on top left 
2	Select <b>About</b> page
3	In the page you find a series of information such as the number and type of license, the active modules.

---

## Installing localization packages

Localization packages allow to install in your device some system files necessary to use the product in a particular country or with a particular language. Localization packages can be requested to your GeoMax reference.

Localization packages can contain:

Localization packages content
Voice messages in the corresponding language
Coordinates correction models
Geoid models
Other settings

You can download the localization packages directly from the program.

Step	Description
2	Run <b>X-PAD</b> 
3	Hit <b>Settings</b> button
4	Select <b>Miscellaneous</b> option
5	Hit <b>Install</b> button corresponding to <b>Localization</b> text
	Hit the button <b>Download</b> In the lower right
6	The list of all available localization packages in the controller appears
7	Select packages to install to run installation
8	The corresponding file can be deleted automatically at the end of the installation procedure to gain space in the disk

Without internet connection localization package can be downloaded from the links below:

## Localization package files

	X-PAD Ultimate Albania package	
	X-PAD Ultimate Australia package	
	X-PAD Ultimate Bahrain package	
	X-PAD Ultimate Belgium package	
	X-PAD Ultimate Brasil package	
	X-PAD Ultimate CZech package	
	X-PAD Ultimate Estonia package	
	X-PAD Ultimate Finland package	
	X-PAD Ultimate France package	
	X-PAD Ultimate Germany package	
	X-PAD Ultimate Greece package	
	X-PAD Ultimate Hungary package	
	X-PAD Ultimate Ireland package	
	X-PAD Ultimate Israel package	
	X-PAD Ultimate Italy package	
	X-PAD Ultimate Korean package	
	X-PAD Ultimate Latvia package	

	X-PAD Ultimate Lithuania package	
	X-PAD Ultimate Mexico package	
	X-PAD Ultimate Netherlands package	
	X-PAD Ultimate New Zealand package	
	X-PAD Ultimate Norway package	
	X-PAD Ultimate Philippines package	
	X-PAD Ultimate Poland package	
	X-PAD Ultimate Qatar package	
	X-PAD Ultimate Romania package	
	X-PAD Ultimate Russia package	
	X-PAD Ultimate Slovakia package	
	X-PAD Ultimate South Africa package	
	X-PAD Ultimate Spain package	
	X-PAD Ultimate Sweden package	
	X-PAD Ultimate Turkey package	
	X-PAD Ultimate UK package	
	X-PAD Ultimate US package	



Perform the following steps to install the localization package:

Step	Description
1	Copy the localization package file in the folder <b>X-PAD</b> of the device
2	Run <b>X-PAD</b> 
3	Hit <b>Settings</b> button
4	Select <b>Miscellaneous</b> option
5	Hit <b>Install</b> button corresponding to <b>Localization</b> text
6	The list of all available localization packages in the controller appears
7	Select packages to install to run installation
8	The corresponding file can be deleted automatically at the end of the installation procedure to gain space in the disk

## Automatic updates

At start **X-PAD** check automatically for updates; if an update is available the corresponding icon appears in the main screen top bar.

Step	Description
1	Click on  button to see the list of new items in the update
2	Hit <b>Install</b> to download the update and install it

 News in update
 11:47

**News X-PAD Survey release 2.7.608**

October 2016

**General**



- **Geoid:** fixed an error that didn't allow the calculation of the elevations for some countries only.

**News X-PAD Survey release 2.7.605**

October 2016

**General**

- **Fixed bugs:** some small bugs has been fixed.
- **Geoid:** fixed an error that didn't allow the calculation of the elevations for some countries

 Install

## Restoring a previous version

All updates that are downloaded and installed on the device are saved to allow eventual restoring of a previous version.

Step	Description
1	Click on <b>X-PAD</b> icon on top left 
2	Select <b>Releases</b> page

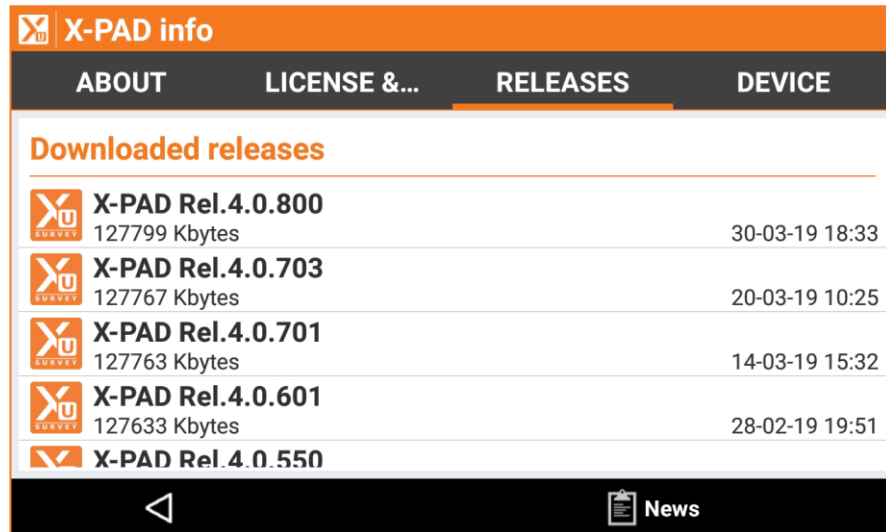

The screenshot shows the 'X-PAD info' application interface. At the top, there is a navigation bar with four tabs: 'ABOUT', 'LICENSE &...', 'RELEASES', and 'DEVICE'. The 'RELEASES' tab is currently selected. Below the navigation bar, the title 'Downloaded releases' is displayed. A list of five releases is shown, each with an 'X-PAD' logo, the version number, the file size in Kbytes, and the download date and time. The bottom of the screen features a black navigation bar with a back arrow on the left and a 'News' icon on the right.

Version	Size (Kbytes)	Date/Time
X-PAD Rel.4.0.800	127799	30-03-19 18:33
X-PAD Rel.4.0.703	127767	20-03-19 10:25
X-PAD Rel.4.0.701	127763	14-03-19 15:32
X-PAD Rel.4.0.601	127633	28-02-19 19:51
X-PAD Rel.4.0.550		



# Workspace

Understanding the rules about operating with the workspace is essential to use the software quickly and efficiently.



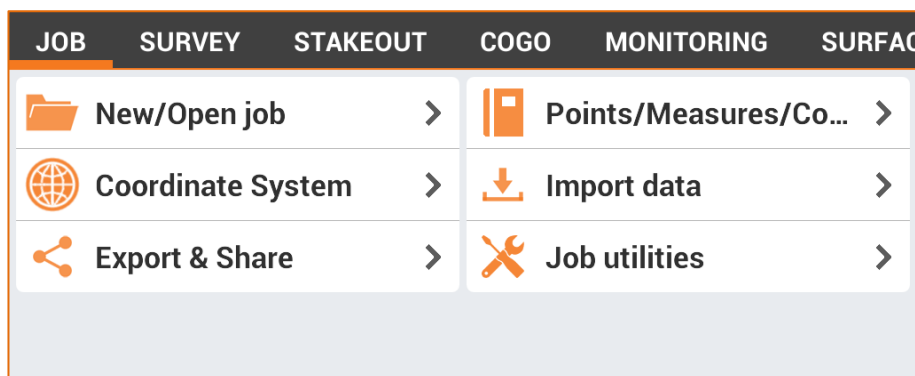

## Main window

The main window is characterized by the menu that organizes the different commands basing on their function.



In the lower part there are the general purpose commands.













Command	Description
 CAD	Enter the graphic CAD
 GPS	Enter the window that allows to control general status of the connected receiver and to change current profile. The icon represent the type of instrument actually connected: <b>Rover GPS</b> or <b>Base GPS</b> .
 TPS	Access to window allowing to perform simple measures with the total station and to check all measuring settings
 Settings	Enter the widow that allows to set parameters of the receiver and of the software
 Quit	Quit software

## Dialog boxes

Dialog boxes are characterized by an upper bar reporting several useful information:











Object		Description
X-PAD icon		Clicking on this icon you access to general information about software, license, active modules and previously installed versions.
Job name or screen title		In main screen you can see the name of the job, in the dialog box the title of the box.
Update available		The presence of this icon indicates that an <b>X-PAD</b> update is available; click on the icon to see the new items contained in the update and proceed with download and installation.
Weather		Icon shows the current weather; by clicking on it a window with weather forecast for the next hours and days is shown.
Device battery		Device battery charge. By clicking on it a window with several information about device is shown.
GPS Battery		GPS receiver battery level. Clicking on icon it's shown a window with several information about receiver or total station.
X-POLE		Measurement with X-POLE mode; allows you to switch to the other type of instrumentation. If you are using the GNSS receiver, you can switch to using the total station and vice versa.
TPS Battery		Total station battery level. Clicking on icon it's shown a window with several information about receiver or total station.
X-Live		Access to the X-Live chat.
X-Live notifications		Shows the presence of a new X-Live notification and access to chat.
Voice command		Enables/Disables the use of voice commands during operations.

In the lower part of most part of the dialog boxes there is a bar containing commands you can use in the box.



### Standard buttons

Button	Description
	Closes the window; in a Step by Step procedure goes back to previous Step.
	Saves content of the fields and closes the window.
	Saves results obtained and continues with procedure.
	Utilities to manage window data.
	Adds a new item to data present in the window.
	Eliminates selected objects present in the window.
	In a Step by Step procedure loads the next page.
	Allows to access to cloud servers; you can download files from a cloud server on the controller but also save in the cloud server files generated by the software.



Activates procedure for stakeout of the point

## Weather forecast

This window shows the weather forecast for next hours and next days.

Weather	
<b>Oderzo</b> broken clouds	14°C
<b>Saturday 13 April</b> few clouds	14°C >
<b>Sunday 14 April</b> light rain	11°C >
<b>Monday 15 April</b> clear sky	16°C >
<b>Tuesday 16 April</b> few clouds	15°C >

Clicking on a day the weather forecast for the hours of that day is shown.

Button	Description
	Update weather forecast

## Device information

This page shows general information about device.

Step	Description
1	Click on <b>X-PAD</b> icon on top left
2	Select <b>Device</b> page.

X-PAD info			
ABOUT	LICENSE &...	RELEASES	DEVICE
<b>Device info</b>			
Battery level			
Free Memory	1608937 Kbytes		
Manufacturer	SAMSUNG		

---

## Receiver/total station information





This window shows general information about GPS receiver or total station connected.

---

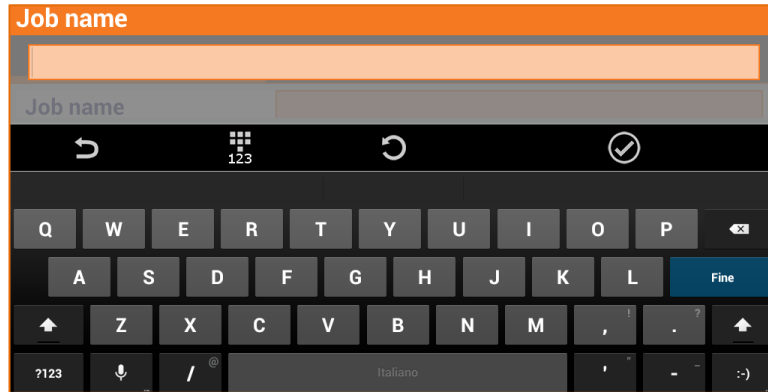
## Virtual keyboard

To access virtual keyboard from an input field click inside the field itself. Virtual keyboard allows to insert alphabetic, numeric and symbols.



Button	Description
	Closes the window
	Activates the alphabetic keyboard
	Activates numeric keyboard
	Restores the starting value
	Saves content of the fields and closes the window.

---

## Inserting latitude and longitude values

In the input fields representing latitude and longitude values, you have to insert values according to this rule:

**<sign>GG.MMSSsss**

Character	Description
<b>&lt;sign&gt;</b>	+ for latitude North and longitude East - for latitude South and longitude West
<b>GG</b>	Decimal degrees
<b>.</b>	Separator
<b>MM</b>	Two characters for minutes
<b>SS</b>	Two characters for seconds
<b>sss</b>	Tenths of a second

Value	Value to input
<b>12°34'56.7890 N</b>	12.34567890

<b>12°34'56.7890 S</b>	-12.34567890
<b>123°45'56.7890 E</b>	123.45567890
<b>123°45'56.7890 W</b>	-123.45567890

---

## Inserting fractional feet

Distance and coordinate values can be input as fractional feet. The accepted format is as follows:

**<feet>' <inches> <fraction of an inch>"**

For example:

Value	Entry value
<b>5 feet, 6 inches and one fourth</b>	<b>5' 6 1/4"</b>



## Job managing

Jobs are organized in Sites; you can create new sites and manage existing sites; every new job is created in the current site. Every site can contain several jobs.

### Sites managing



The list of the sites present in the device is shown. For every site, the number of jobs present is indicated.

Button	Description
LIST	Alphabetic list of the sites
MAP	Sites are shown on Google map
 NEW	To create a new site
	Allows to change the visualization order of the sites: alphabetic, ascending or descending

### Setting current site



Select line corresponding to the site to setup as current site; you go back to window with jobs list; only jobs of the selected site are shown.

### Creating a new site



Field	Description
Site name	Name of the site to create
POSITION	Address and position of the site; if your device has a valid GPS position it is automatically reported. Or you can select the location on the map by holding down on the map in the desired position. If your device is connected to internet it's shown also corresponding address.

### Deleting a site





Select site to delete. Jobs contained in the site will be deleted and these can no longer be recovered.

---

## Jobs managing

The list of the jobs present in the device is visualized according to different modes.

### Visualization modes

Mode	Description	
GALLERY	Jobs gallery	
LIST	List of jobs	
MAP	Visualization of the jobs on Google map.	
CALENDAR	Visualization of the jobs on the calendar	

### Gallery

Jobs are visualized on a circular, merry-go-round, view with the picture associated to the job or with a preview picture of the drawing; they are reported also information about the editing date of the file and its dimension. Click on picture to proceed opening the job.

### List









Jobs are listed on a list together with the editing date and file dimension. Click on the row corresponding to the job to proceed opening it.

### Map

The position of every job is represented on the Google map; click on icon to have information about a job and to proceed opening it. If in the same zone there are several jobs a corresponding list is shown.

### Calendar

Jobs are visualized on a calendar basing on their creation date. To pen a job click on corresponding day; if one day several jobs are created, the number of created jobs is shown on that day and then the list is visualized.

Button	Description
	Sites management
	Gallery view
	List view
	Map view
	Calendar view
	Access to jobs present on Cloud platform as Dropbox, Google Drive, SkyDrive.
	Allows to change the jobs visualization order: alphabetic ascending or descending, editing date ascending or descending.
	New job creation

## Creating a new job

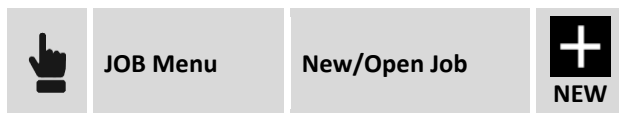

Field	Description
Site	Site in which the job will be created
Job name	Name of the job to create
Reference job	You can create a link between the new job and an existing job; when you open the job, the points present in the reference job will be loaded in the new job as reference points and they can be used for all the operation of orientation of the total station, calibration of the GPS site, etc.
Codes library	A survey codes library to link with the job. The library contains a list of codes, descriptions and symbols that can be used to describe the measured points.
GIS features	GIS features library to associate to the job. The library contains definitions of GIS features and of properties that can be associated to the survey codes; when a point is saved, in addition to position it's possible to save the properties defined by the associated GIS feature. 
Annotation	Descriptive notes of the job.
COORDINATES SYSTEM	They are visualized information about the coordinates system assigned to the new job. To the new job it's assigned the coordinates system set as default system.
POSITION	Address and position of the job; if your device has a valid GPS position it is automatically reported. Or you can select the location on the map by holding down on the map in the desired position. If your device is connected to internet it's visualized also the corresponding address.
PHOTO	Picture associated to job. It's possible to use an image still present on controller or to shoot a new photo. Photo will be used to represent the job in the Gallery view.

## Opening an existing job



Select the site containing the job to open; then select the job from the gallery, from the list, from the Google map or from the calendar.

## Opening a job saved on Cloud server



Step	Description
1	Select the cloud server in which jobs are saved
2	Sometimes it's asked the login at server.



## Properties of the job

	<b>JOB Menu</b>	<b>Job utilities</b>	<b>Job properties</b>
---	-----------------	----------------------	-----------------------

Field	Description
<b>Site</b>	Site of the job
<b>Job name</b>	Name of the job
<b>Reference job</b>	You can create a link between the new job and an existing job; when you open the job, the points present in the reference job will be loaded in the new job as reference points and they can be used for all the operation of orientation of the total station, calibration of the GPS site, etc.
<b>Codes library</b>	A survey codes library to link with the job. The library contains a list of codes, descriptions and symbols that can be used to describe the measured points.
<b>GIS features</b>	GIS features library to associate to the job. The library contains definitions of GIS features and of properties that can be associated to the survey codes; when a point is saved, in addition to position it's possible to save the properties defined by the associated GIS feature. 
<b>Notes</b>	Descriptive notes of the job.
<b>COORDINATES SYSTEM</b>	They are visualized information about the coordinates system assigned to the new job. To the new job it's assigned the coordinates system set as default system.
<b>POSITION</b>	Address and position of the job; if your device has a valid GPS position it is automatically reported. Or you can select the location on the map by holding down on the map in the desired position. If your device is connected to internet it's visualized also the corresponding address.

## Copying or sending a copy of the current job

You can perform the operation by selecting

	<b>JOB Menu</b>	<b>Job utilities</b>	<b>Save a copy of the job</b>
---	-----------------	----------------------	-------------------------------



It allows you to save the open work and all the linked files.

Field	Description
<b>File name</b>	Name to assign to the copy of the job
<b>Device/Cloud</b>	Allows to save the copy of the job on your device or on a cloud server.
<b>Share file</b>	Allows to use services available on your Android device as sending file by e-mail, by WI-Fi, Bluetooth, etc.

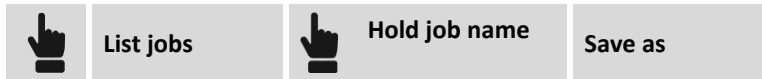
Or by selecting



It allows you to save the open job and all the linked files.

Field	Description
File name	Name to assign to the copy of the job
Cloud	Allows to save the copy of the job on your device or on a cloud server. This option is available by holding the job name selecting <b>Save as</b> .
	Allows you to store a copy of the job in a memory unit connected to the device. This option is available by holding the job name selecting <b>Save as</b> .
	Allows you to store a copy of the job in a device folder. This option is available by holding the job name selecting <b>Save as</b> .

### Deleting a job

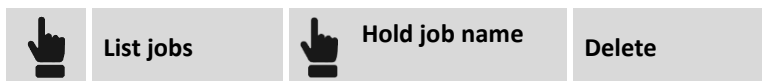
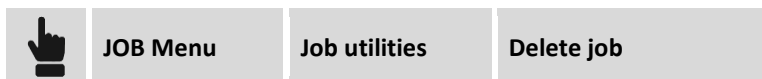

Select jobs to delete.

The first command allows you to select the jobs to be deleted. The command deletes the selected job files and all linked files.

The second command deletes only the selected work and all the linked files.

### Rename a job



The command renames the selected job and all the linked files.

### Compact and repair a job

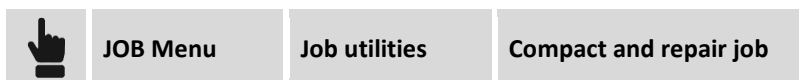

Procedure allows to perform a compaction and eventually a restore of an existing job where many data deleting are made or it's corrupted. Selection of the job to process is required; a copy of the original job is created.

### Restoring a job



The restoring procedure allows to import in a new job the RAW file of another job that is damaged and that you can't open no more. You are asked to select the RAW file to load and to assign a name to the new file to create.

Step	Description
1	Select RAW file of the job to restore
2	Assign a name to the new job to create containing the restore data

### Job file

Every job is saved in a file with **GFD4** extension. When you open the job a copy is created automatically with **GFD4\_BAK** extension.

Moreover, to every closure of the job the RAW file is created with **RAW** extension; the RAW file it's a text file reporting all essential data of the job: topographic points and measures. The RAW file can be used by third-party software to import data.

Sketches associated to points or to measures fieldbook are saved in a sub-folder of the folder of the job; the name of the sub-folder is **<name of the job>\_IMG**.

### Conversion of X-PAD Survey 3 files

if you want to open a job created with X-PAD Survey 3 you need to perform a conversion. Jobs created with the

previous version of the program are shown in the work list with the icon .

The procedure keeps the original job and creates a copy of the job in the new format.

Perform the following procedure to convert the job:



Step	Description
1	Select the job file to convert.
2	Press <b>YES</b> to execute the conversion.

---

# Settings

The software operations are subjected to a series of parameters and options that are fully customizable by the user.

---

## Units



The page allows to set the units of measure to use for every type of data.

---

## Decimals



The page allows to set the number of decimals to show for every type of data.

---

## Coordinates



The page allows to set the symbols to mark the abscissa, the ordinates and the elevations. Moreover it's possible to set the order of visualization and insertion of abscissa and ordinates. Moreover it's possible to set direction of the ordinates: the default direction of the ordinates is toward North but in some countries it's inverted.

---

## GNSS



The tab allows to set several parameters controlling the acquisition of the positions of the GPS receiver and that set the functioning modes.

### Tab GNSS



#### GNSS Accuracy check

Field	Description
Store only in fixed	The epochs recording is done only if the receiver is in fixed position.
Accuracy check	Activates accuracy check; GPS epoch is accepted if the current precision satisfies the preset precision conditions.
RTK age check	Enables control of receiving RTK corrections. If it is active, corrections must be received within the time set to store the point.

<b>Max age (secs)</b>	Sets the maximum time that the new RTK fix needs to be received.
<b>H</b>	Maximum horizontal precision to make acceptable the GPS epoch
<b>V</b>	Maximum vertical precision (elevation) to make acceptable the GPS epoch
<b>DOP check</b>	Activates the check on DOP value; the GPS epoch is accepted only if the DOP value is lower than the preset one.
<b>Max DOP</b>	Maximum DOP value to make acceptable the GPS epoch.
<b>Satellites check</b>	Activates the number of satellites check; the GPS epoch is accepted only if the number of tracked satellites is more than the minimum value preset.
<b>Min Satellites</b>	Minimum number of satellites to make acceptable the GPS epoch.
<b>Sensor mode</b>	<p>It's possible to set the use of different types of sensors in surveying and stakeout phases:</p> <ul style="list-style-type: none"> <li>• <b>None:</b> no sensor</li> <li>• <b>E-bubble (controller):</b> activates the use of electronic bubble of the controller; the GPS epoch is accepted only if the electronic bubble is inside the tolerance range.</li> <li>• <b>E-bubble (GPS receiver):</b> activates the use of electronic bubble of the GPS receiver (if present); the GPS epoch is accepted only if the electronic bubble is inside the tolerance range.</li> <li>• <b>Tilted pole (GPS receiver):</b> activates the use of tilt and compass sensors of the GPS receiver (if present). Sensors allow to calculate the position of the point even if the pole is not vertical.</li> </ul>
<b>Max error (2m pole)</b>	Maximum error acceptable outside the bubble considering a 2 meters pole.
<b>Localization zone check</b>	<p>Activates the GPS localization zone check; if a coordinates system defined by a localization on more than 2 points is set, the software verifies if the receiver position is inside the localization zone; if current position is external to localization zone an icon on coordinates panel is visualized in survey and stakeout windows. The localization zone is drawn in the graphic window.</p> 
<b>Measures average</b>	Activates calculation of the average of coordinates of a point when it's measured more times.
<b>Horizontal</b>	Tolerance on distances and elevations: if a measure differs, referring to average value, more than tolerance it's considered out of tolerance and highlighted in the list of measures.
<b>Vertical</b>	

### Miscellaneous

Field	Description
<b>GNSS position symbol</b>	Select the symbol that represents the position of the GNSS receiver during surveying.
<b>GNSS symbol 3D</b>	Enables the display of the instrument's 3D symbol, when the 3D view is active in the survey and stakeout graphics window.
<b>Configure always GNSS reciver</b>	Enables the complete reconfiguration of the receiver with the current profile at each connection with the controller.

### Tab SURVEY

	Settings	GNSS	Tab SURVEY
---	----------	------	------------

The tab allows to set the main functioning parameters for the different GPS survey modes.

### GPS survey

Field	Description
Measure mode	<b>Automatic:</b> measure ends automatically after the preset number of seconds
Time on point (sec)	Seconds of acquisition of the position of the point; for every second it's saved a number of epochs equal to frequency set in the GPS profile. In case of 1Hz frequency it's saved one position (epoch) per second; for a frequency of 5Hz they are saved 5 positions per second.
Time on Master Point (sec)	Sets the seconds of acquisition of the position for a point of type Master point.

### Automatic survey

Field	Description
Measure mode	Mode to use for the automatic points survey: <ul style="list-style-type: none"> <li>• <b>Time:</b> position is acquired in preset intervals of time</li> <li>• <b>Distance 2D:</b> position is acquired in preset intervals of horizontal distance</li> <li>• <b>Distance 3D:</b> position is acquired in preset intervals of three-dimensional distance</li> <li>• <b>Distance 2D Plus:</b> position is acquired at preset intervals of horizontal distance and height difference according to settings.</li> <li>• <b>Stop &amp; Go:</b> position is acquired according to Stop &amp; Go mode; when the antenna remains in still position the software begins to acquire the position.</li> </ul>
Measure every (sec)	In case of <b>Time</b> mode, defines the interval of time among the automatic acquisition of positions.
Distance 2D	In case of <b>2D Distance</b> mode, defines the interval of horizontal distance that must intervene between position to acquire and position previously acquired.
Distance 3D	In case of <b>3D Distance</b> mode, defines the interval of three-dimensional distance that must intervene between position to acquire and position previously acquired.
Distance 2D plus	In case of <b>2D Distance plus</b> mode, defines the interval of horizontal distance and the height difference that must intervene between position to acquire and position previously acquired. The point is acquired when one of the set values is exceeded.
Stop time (sec)	In case of <b>Stop &amp; Go</b> mode, defines the time to stay on the point to allow the acquisition of position.
Max. movement antenna	In case of <b>Stop &amp; Go</b> mode, represent the maximum movement allowed to consider "still" the antenna; when the software identifies that the antenna remains in position almost still, with a movement lower than the maximum value, the acquisition of the position begins for the defined stop time.

### Post-Processing survey

Field	Description
Measure mode	<b>Automatic:</b> measure ends automatically after the set number of seconds.

## Survey codes

Field	Description
<b>Numeric codes</b>	Activates a preferential use of numeric codes concerning survey codes. The virtual keyboard appearing is the numeric one.
<b>Measure after Quick Code</b>	Activating this option it's automatically started the measure immediately after the selection of the Quick Code.
<b>Add new codes to library</b>	When the option is active, if you use code that did not store in the library during the surveying, it will be added automatically.
<b>GIS line attributes for all points</b>	When the option is active, GIS attributes will be required for each point of the line, otherwise they will only be required for the first point of the line.

## Average coordinates

Field	Description
<b>Average coords</b>	Enables the calculation of the mean value of the coordinates of a point when it is measured several times.
<b>Max H</b>	Sets tolerance on distances and elevation: If a measure differs from the average value, a quantity greater than the tolerance is considered out of tolerance and highlighted in the list of measures.
<b>Max V</b>	

## Miscellaneous

Field	Description
<b>Survey display mode</b>	<p>Sets the default display mode of the survey graphics window performed with GNSS.</p> <p><b>2D (walk direction):</b> displays items of drawing and surveying in 2D oriented mode according to the direction of the antenna.</p> <p><b>2D (North):</b> displays items of drawing and surveying in 2D oriented mode according to the North.</p> <p><b>3D (walk direction):</b> displays items of drawing and surveying in 3D oriented mode according to the direction of the rover.</p> <p><b>Map (Google or others):</b> displays a reference map in surveying operation.</p> <p><b>Augmented Reality:</b> Display the items of drawing and surveying put on the current view of the device camera.</p>
<b>Store tagged sketch/photo</b>	<p>When you take a photo linked with the point, the following information is shown at the bottom:</p> <ul style="list-style-type: none"> <li>- Point name.</li> <li>- Coordinates (E, N, Z).</li> <li>- Date and time.</li> </ul>

## Tab STAKEOUT



The different tabs allow to set the functioning and control parameters for the GPS stakeout.

## Tolerance

Field	Description
Distance tolerance	Maximum horizontal distance between current position and position to reach to consider being on stakeout position; if the distance between current position and position to reach is lower or equal to tolerance, the software reports the reaching of stakeout position.
Elevation tolerance	Maximum acceptable difference between current elevation and stakeout elevation; if the elevation difference is lower or equal to tolerance the software reports the reaching of the position in elevation.

## Miscellaneous

Field	Description
Vocal info	Activates the vocal information during the stakeout operations.
Confirm before saving	Allows checking the stakeout position before proceeding to saving new point on position to stakeout. Disabling this option the stakeout point is saved without any further request.
Reference GNSS	Defines reference referring to which the information to reach the stakeout position with the GPS are provided. References can be: <ul style="list-style-type: none"><li>- <b>North</b>: information are provided referring to the North; turn the controller toward the North and follow indications.</li><li>- <b>Sun</b>: information are provided referring to the Sun; turn the controller toward the Sun and follow indications.</li><li>- <b>Point</b>: information are provided referring to a reference point previously defined; turn the controller toward the point and follow indications.</li></ul>
Compass limit	Distance determining the automatic change of visualization of the stakeout information; if the distance of the receiver from the point to stakeout is more than the preset value it appears the arrow indicating direction; if the distance of the receiver from the point to stakeout is lower than the preset value it appears the stakeout sketch with the reference to <b>North</b> , to <b>Sun</b> or to <b>Point</b> .
Stakeout display mode	Sets the default display mode of the stakeout graphics window performed with GNSS. <b>2D (walk direction)</b> : displays items of drawing and staking out in 2D oriented mode according to the direction of the antenna. <b>2D (North)</b> : displays items of drawing and staking out in 2D oriented mode according to the North. <b>3D (walk direction)</b> : displays items of drawing and staking out in 3D oriented mode according to the direction of the antenna. <b>Map (Google or others)</b> : displays a reference map in the staking out operation. <b>Augmented Reality</b> : Display the items of the drawing and staking out put on the current view of the device camera.

## Tab POINTS NAME



The window allows you to customize the point name according to the point kind. If the point name is composed of letters and numbers, the program will only increase the numerical part during operations.

For example:



Field	Description
Survey	P1

It means that the name of all points of the surveying will start with the P and the number will increase from the one (P1, P2, P3, P4...).

## TPS



The tab allows to set the total station survey functioning and control parameters.

### Tab TPS



### Accuracy check

Field	Description
Horizontal angle (sec)	Maximum acceptable error on horizontal angle in multiple measures and in measures on Face 1 and Face 2.
Vertical angle (sec)	Maximum acceptable error on vertical angle in multiple measures and in measures on Face 1 and Face 2.
Distance	Maximum acceptable error on distance in multiple measures and in measures on Face 1 and Face 2.
Elevation	Maximum acceptable error on elevation in multiple measures and in measures on Face 1 and Face 2.
E-bubble check	Activates the use of electronic bubble; The electronic bubble is visualized in the survey and stakeout windows.
Maximum error (2m pole)	Maximum error acceptable outside the bubble considering a 2 meters pole.

### Prism lost search strategy

Field	Description
Search after lost	<p>Activates the automatic searching of the prism after the total station lose it. The automatic searching mode after the prism is lost are:</p> <ul style="list-style-type: none"> <li>• <b>None:</b> no action</li> <li>• <b>360° Search:</b> a 360° search of the prism is started</li> <li>• <b>Window + 360° Search:</b> a window search in the zone where the prism is lost is started and then a 360° search</li> <li>• <b>Return to last position:</b> the station goes in the last position where the prism was locked</li> <li>• <b>Use controller's GNSS:</b> use the GPS location of the controller to search for the prism.</li> </ul>

## Miscellaneous

Field	Description
TPS symbol 3D	Displays the 3D symbol of the TPS, when the 3D view is active in the graphic window of survey or stakeout.

## Tab SURVEY

	Settings	TPS	Tab SURVEY
---	----------	-----	------------

## Number of measurements

Field	Description
Standard	Sets the number of measures that the TPS must perform before storing a point.
Master point	Sets the number of measures that the TPS must perform before storing a point of type Master point.

## Automatic survey

Field	Description
Measure mode	Mode to use for the automatic points survey: <ul style="list-style-type: none"><li>• <b>Time</b>: position is acquired in preset intervals of time</li><li>• <b>Distance 2D</b>: position is acquired in preset intervals of horizontal distance</li><li>• <b>Distance 3D</b>: position is acquired in preset intervals of three-dimensional distance</li><li>• <b>Distance 2D Plus</b>: position is acquired at preset intervals of horizontal distance and height difference according to settings.</li><li>• <b>Stop &amp; Go</b>: position is acquired according to Stop &amp; Go mode; when the antenna remains in still position the software begins to acquire the position.</li></ul>
Measure every (sec)	In case of <b>Time</b> mode, defines the interval of time among the automatic acquisition of positions.
Distance 2D	In case of <b>2D Distance</b> mode, defines the interval of horizontal distance that must intervene between position to acquire and position previously acquired.
Distance 3D	In case of <b>3D Distance</b> mode, defines the interval of three-dimensional distance that must intervene between position to acquire and position previously acquired.
Distance 2D plus	In case of <b>2D Distance plus</b> mode, defines the interval of horizontal distance and the height difference that must intervene between position to acquire and position previously acquired. The point is acquired when one of the set values is exceeded.
Stop time (sec)	In case of <b>Stop &amp; Go</b> mode, defines the time to stay on the point to allow the acquisition of position.

### Survey codes

Field	Description
<b>Numeric codes</b>	Activates a preferential use of numeric codes concerning survey codes. The virtual keyboard appearing is the numeric one.
<b>Measure after Quick Code</b>	Activating this option it's automatically started the measure immediately after the selection of the Quick Code.
<b>Add new codes to library</b>	When the option is active, if you use code that did not store in the library during the surveying, it will be added automatically.
<b>GIS line attributes for all points</b>	When the option is active, GIS attributes will be required for each point of the line, otherwise they will only be required for the first point of the line.

### Average coordinates

Field	Description
<b>Average coords</b>	Activates calculation of the average of coordinates of a point when it's measures more times.
<b>Max H</b>	Tolerance on distances and elevations: if a measure differs, referring to average value, more than tolerance it's considered out of tolerance and highlighted in the list of measures.
<b>Max V</b>	

### Miscellaneous

Field	Description
<b>Survey display mode</b>	Sets the default display mode of the survey graphics window performed with total station. <b>2D (TPS direction)</b> : displays items of drawing and surveying in 2D oriented mode according to the direction of the total station. <b>2D (north)</b> : displays items of drawing and surveying in 2D oriented mode according to the North. <b>3D (TPS direction)</b> : displays items of drawing and surveying in 3D oriented mode according to the direction of the TPS. The program shows the direction based on the position of the controller, which can be behind the TPS or behind the pole.
<b>Store tagged sketch/photo</b>	When you take a photo linked with the point, the following information is shown at the bottom: <ul style="list-style-type: none"> <li>- Point name.</li> <li>- Coordinates (E, N, Z).</li> <li>- Date and time.</li> </ul>

### Tab STAKEOUT

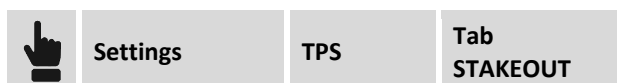

The tab allows to set the functioning and control parameters for the total station stakeout.

## Stakeout

Field	Description
<b>Distance tolerance</b>	Maximum horizontal distance between current position and position to reach to consider being on stakeout position; if the distance between current position and position to reach is lower or equal to tolerance, the software reports the reaching of stakeout position.
<b>Elevation tolerance</b>	Maximum acceptable difference between current elevation and stakeout elevation; if the elevation difference is lower or equal to tolerance the software reports the reaching of the position in elevation.

## Miscellaneous

Field	Description
<b>Vocal info</b>	Activates the vocal information during the stakeout operations.
<b>Confirm before saving</b>	Allows checking the stakeout position before proceeding to saving new point on position to stakeout. Disabling this option the stakeout point is saved without any further request.
<b>Tacking mode</b>	When this option is activated the tracking mode is always set with the continuous surveying mode.
<b>Reference TPS</b>	Defines reference referring to which the information to reach the stakeout position with the total station are provided. References can be: <ul style="list-style-type: none"> <li>- <b>Target:</b> information are provided considering the operator on the target looking toward the total station.</li> <li>- <b>Total station:</b> : information are provided considering the operator on the TPS.</li> <li>- <b>North:</b> : information are provided referring to North.</li> </ul>
<b>Turn toward point</b>	When this option is activated the motorized total station turns automatically toward the stakeout point when it's selected.
<b>Stakeout display mode</b>	Sets the default display mode of the survey graphics window performed with total station. <p><b>2D (TPS direction):</b> displays items of drawing and surveying in 2D oriented mode according to the direction of the total station.</p> <p><b>2D (north):</b> displays items of drawing and surveying in 2D oriented mode according to the North.</p> <p><b>3D (TPS direction):</b> displays items of drawing and surveying in 3D oriented mode according to the direction of the TPS. The program shows the direction based on the position of the controller, which can be behind the TPS or behind the pole.</p>

## Tab POINTS NAME

	Settings	TPS	Tab POINTS NAME
---	----------	-----	-----------------

The window allows you to customize the point name according to the point kind. If the point name is composed of letters and numbers, the program will only increase the numerical part during operations.

For example:

Field	Description
<b>Survey</b>	P1

It means that the name of all points of the surveying will start with the P and the number will increase from the one (P1, P2, P3, P4...).

## CAD

The tab allows you to set different display parameters of the CAD workspace.



## Tab Survey



Field	Description
Topographic points	Turns on/off the display of stored points.
Reference points	Turns on/off the display of Reference points.
Stakeout points	Turns on/off the display of stakeout points.
Collaborative points	Turns on/off the display of X-Live points.
Measure lines	Turns on/off the display of measure lines.
Drawing by codes	Turns on/off the display of drawing by codes.
Parcels	Turns on/off the display of parcels

## Tab POINTS

### Points display filters

Field	Description
Point name	Turns on/off the display of the point name.
Point elevation	Turns on/off the display of the point elevation.
Point code	Turns on/off the display of the point code.
Point description	Turns on/off the display of the point description.
Point symbol	Turns on/off the display of the point symbol.

### Points symbol and label size

Field	Description
Label with background	Turns on/off the display of the label background.
Point size	Allows to set the size used to display the text of labels.
Auto size label in 3D	Turns on/off automatic text size management when 3D display is active. If the option is active, the size of the text changes depending on the distance. The closest texts will be displayed with a larger size than the furthest ones.

## Tab CAD

### CAD display filter

Field	Description
Main drawing	Turns on/off the display of drawing elements.
External reference	Turns on/off the display of the elements stored in the external reference.
Use linetypes	Turns on/off the display of the linetype associated with the drawing elements .
Line double thickness	Turns on/off the display of drawing elements with a doubled thickness.
Mono color drawing	Turns on/off the display of drawing elements colors.
Autocenter in drawing	Turns on/off the autocenter of the drawing. During drawing operations, each time a CAD location is set, it is shown in the center of the graphical window.
Grid	Turns on/off the display of the grid in the CAD window.
Grid step	Sets the steps of the grid.

### AR settings

Field	Description
Height from ground	Sets the height of the point of view, when augmented reality display mode is active.
Radar	Turns on the display of the bottom right panel representing the plan view.

---

## Laser scanner

	Settings	Laser scanner
---	----------	---------------

The tab allows to activate the Laser scanner survey mode: this mode becomes useful when you operate with laser scanner, with a GPS receiver installed over it and with a receiver located on one or more targets. Directly from XPAD it's possible to acquire positions of the scan centers and of the targets identified by a specific prefix; in correspondence of the scan centers it's drawn a circle which radius represents the average covering reached by the scanner. The circle drawing of the still covered zones allows to state the correct positioning of the next scans to guarantee a good covering of all area.

Field	Description
Draw scan zone	Enables drawing of the scanning zone; the drawing consists in a circle having the center in the scan points.
Scan radius	Radius to use for the drawing of the scan area; corresponds to the average range of the scanner.
Prefix scan center	Prefix with which the scan centers has to be identified; in correspondence of the scan centers they will be drawn the scan zones.
Prefix target	Prefix with which they are indicated the target points.
Scanner control	Enables the scanner control mode directly from X-PAD; in survey menu it's added an item allowing to access to web page to control the scanner (in case of GeoMax Zoom300 scanner).

---

## X-Live



The tab allows to set the functioning mode of X-Live system that is explained in chapter **X-Live the collaborative survey**.

---

## Miscellaneous

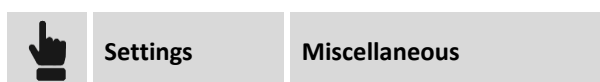

### Miscellaneous

Field	Description
Immediate keyboard	Activating this option the virtual keyboard appears when you click activating the input field; when the option is disabled, to see the keyboard it's necessary to make active the input field and then to click again on the same field.
Meteo Info	Activating this option the software will query periodically the server to have updated info about the weather.

### Localization settings

Field	Description
Language	Language used by the software; for a correct operation it's necessary to restart the software after modifying the language.
Localization package	Allows installing the localization packages available for the different countries.
Time format	Allows you to set the format 24H or AM/PM.
Date format	Allows you to set the date format.

### Automatic exporting

Field	Description
Format	Allows to set the format type of data to export automatic when closing the job. Enabling this option the software is able to generate automatic the requested format to every closure of the job avoiding this has to be done by the operator.

---

## Voice commands

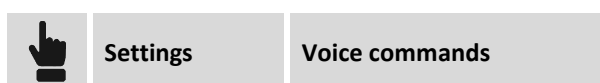

The tab allows to set the vocal commands to execute the operations to management the surveying, stakeout, and handling of TPS and GNSS. It is possible to customize the commands by entering the word you prefer to start the action. In addition, you can improve command recognition reliability by running a self-learning procedure that consists of repeating the command 10 times.

You can restore the default commands using the command:



## Android settings

To use voice commands, you must set the system language correctly in the device settings in the voice recognition menu. Recognition is faster when used in OFF LINE mode.

---

## Commands manager



The tab allows to make visible or invisible every single command of the different menu of the software; this way it's possible to avoid the accidental modification of settings and parameters by inexperienced operators. After setting which commands have to be available a password is requested; to edit then the settings it's necessary to insert again the same password.

---

## X-Do!

X-Do is a physical button that pairs to the controller via Bluetooth and that can be used to start performing some operations.

The available actions are:

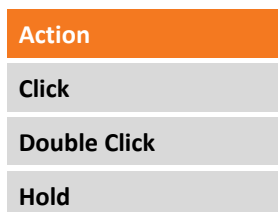

It is possible to connect to each action a specific command of management of the GNSS and TPS survey and stakeout with GNSS and TPS.

---

## Reports



The tab allows to set a text and an image (logo) that will be reported in the heading of every generated report.

---

## Saving and loading settings

All setup can be saved as default setup in order to be the reference setup for every new job. Otherwise it's possible to save setup with a name and then load it when necessary on every other job.

### Save settings as default



Current setup are saved as default setup; every new job will use automatically these setup.



## Save setup as



Insert a name to be used to save current setup.

## Load settings



Select file corresponding to setup to load in current file.

## Points, measures, survey codes and GIS features managing

This set of commands allows to access to numeric visualization of the data present in the job; it's possible to access to the table of the topographic points, of the reference points of the site measures and to survey codes managing.

### Topographic points



Topographic points are all that position characterized by a name and having specific additional features; they can come from direct measuring or from manual inserting or from importing from external files. Table reports the list of all topographic points present in the job; points are listed according to inserting order, so at first place you find the last point inserted. An icon representing the origin of the point, the name, the code and the coordinates is visualized.

Selecting a point it appears a menu allowing to execute specific operations on it.

### Creating a new point









The data of the point are organized in pages.

Coordinates page	
Point	Name of the point
NEZ	Plane coordinates of the point
Geodetic coords	Allows you to enter the geographic coordinates of the point by choosing between: <ul style="list-style-type: none"><li>• Latitude, longitude and height.</li><li>• Earth centered XYZ coordinates.</li></ul>
Lat. / Long. / Elevation	Geographic coordinates of the point

Properties page	
Code	Survey code of the point; the button allows to access to the codes library and to select a code from the list
Description	Extended description of the point
Date	Date and time of the point saving
GIS data	If the GIS module is activated and one or more codes with GIS information has been associated to the point it's possible to use the button <b>Edit</b> to insert and modify the corresponding GIS properties.

### Sketch page

	Deletes sketch and photo
	Restores original content
	Adds a label with main information of the point; the label can be moved in every position
	Adds a label with a free text; the label can be moved in every position
	Adds an arrow symbol; the arrow can be moved and turned
	Enables the free drawing mode
	Starts the application allowing to shoot a photo and save it.

If a point was measured more times and it's activated the option **Average coordinates** in the survey setup, it appears also the **AVERAGE** page. The page reports the different measures used for the coordinates calculation of the point; for every measure are visualized the differences referring to the average value calculated. It's possible to decide which measures to use for the calculation and also to edit directly a measure.

### Editing a point

Select point on table and select the **Edit** item from the appearing menu. The content of the window is the same still seen for creation of a new point.

### Deleting a point

Select point on table and select the **Delete** item to delete the selected point.

### Visualizing point on CAD

Select point on table and select the **Display on CAD** item from the appearing menu; the point is visualized in the center of the graphic window.

### Stakeout of a point

Select point on table and select the **Stakeout** item to start the procedure allowing to stakeout the selected point. For further information see chapter **Stakeout of points**.

### Sharing data of a point

Select point on table and select **Share** item. Chose sharing method and complete procedure; for the selected point will be sent the information related to coordinates (geographic and plane), code, description and eventually the photo/sketch associated.

### Tools of the point page

#### Searching a point

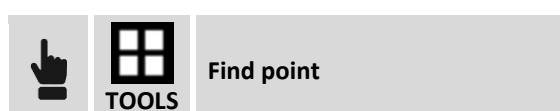

Indicate the name of the point to search; if the point is found it's putted in first view on the table.

### Visualizing Latitude, Longitude and Elevation

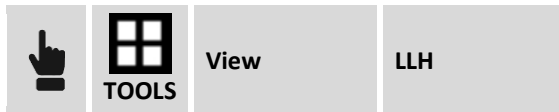

 117	L	N 45°57'09.2289"
	L	E 12°29'39.6190"
	H	52.727m

For every point are visualized the geodetic coordinates, if available.

### Visualizing East/X, North/Y and Elevation/Z

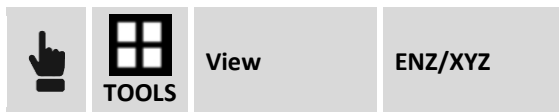

 117	E	234188.135m
	N	78465.442m
	H	-64.167m

For every point are visualized the plane coordinates.

### Visualizing Distance and direction

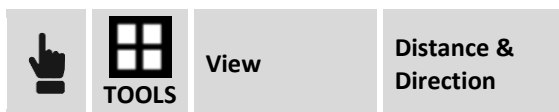

 117	 4m
---	--

For every point is visualized the distance referring to current position and the direction of the point referring to direction of the device. To visualize these information the software can use the GPS receiver connected or the GPS inside the device.

### Set elevation to points



Allows you to set a value to the elevation of the selected points.

### Add elevation to points



Allows you to add a value to the current elevation of selected points.

### Invert coordinates



Allows you to reverse the coordinate sign of all points.

Invert coordinate	
<b>Invert E</b>	Activate the inversion for the east coordinates.
<b>Invert N</b>	Activate the inversion for the north coordinates.

To execute the command, press the **INVERT** key.



### Reset Stakeout state

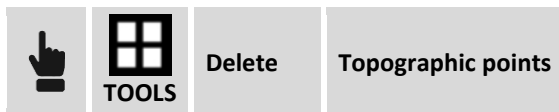

The software saves the staked points with the status of “already stakeout”, in this way it is no longer possible to stakeout them. The command is used to delete this status in order to run the staking again.

### Deleting a group of points



Step	Description
1	Select points to delete
2	Hit  to select or deselect all points of the list.
3	 to proceed with deleting of points.

### Deleting coincident points



Command allows to delete points finding on the same position of another point.

### Diagram Distances/Elevation



Points are displayed on a diagram that has the distances on the horizontal axis and the elevations on the ordinate axis.

### Transferring points on reference points table

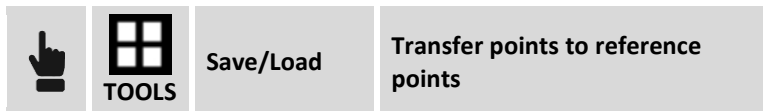



Command allows to copy or move selected points in the reference points table.

Step	Description
1	Select points to copy/move
2	Hit  to select or deselect all points of the list.
3	
4	Specify if copy or move selected points.

### Loading points from a job



Command allows to import points from another job.

Step	Description
1	Select job from which to load points
2	Select points to load; in the page <b>MAP</b> it's possible to visualize points on Google map.
3	Hit  to select or deselect all points of the list.
4	 to proceed with importing procedure

### Saving points on another job



Command allows to export selected points on another job.

Step	Description
1	Select points to save
2	Hit  to select or deselect all points of the list.
3	
4	Select job on which to export selected points

### Changing the visualization order



The command allows to view the list of points according an ascending or descending order, by name of the point or creation date.

---

### Fieldbook of measures

The fieldbook of measures reports the chronologic list of all measures performed on site. The measures are listed according to acquisition order, so at first place you find the last measure performed. For every measure an icon specifying the type of measure, the name of the measured point, the date and time of acquisition, the code, description and other information is visualized.



### Editing a measure

Select measure on the table and select item **Edit** from the appearing menu. In the different pages are reported all data of the measure but only some of them are editable:

Page Point	
Point	Name of the point
Rover Antenna elevation Target elevation	Antenna elevation (GPS) or target elevation (TPS)

Page Code	
Code	Code of the point
Description	Extended description of the point
GIS Data	Allows to edit the GIS attribute.

Page Sketch	
Sketch/Photo	Sketch associated to point

Changing of the antenna or target elevation determinates a new calculation of the elevation of the corresponding topographic point.

### Change target/pole height

Step	Description
1	Select the measure to edit.
2	Choose whether to apply the change to all session measures.
3	Set the value to assign for heigt target/pole.

4



The change of pole or target height results in a recalculation of the elevation of point corresponding to measure.

### Deleting a measure

Select measure on the table and select item **Delete** to delete the selected measure. The measure is not completely erased but the “DELETED” status is assigned. At any time you can restore the measure.



### Restore deleted measure

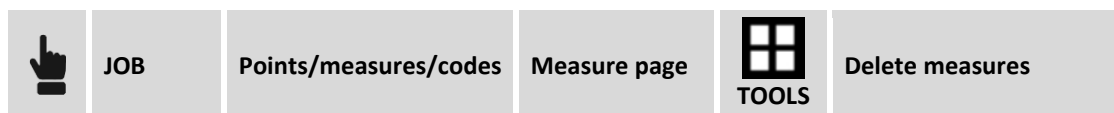

Select measure on the table that has the status “DELETED” marked by icon  and select **Restore**.

### Deleting a group of measures



Step	Description
1	Select measures to delete
2	Hit  to select or deselect all points of the list.
3	 to proceed to deleting measure.

### Searching a measure

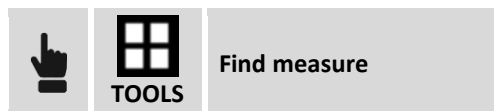

Indicate the name of the point to search; if the corresponding measure is found it's putted as first on the table and selected.

### Visualizing notes

Table reports the list of measure but, among measures, it's also possible to visualize notes; there are two types of notes:

#### Automatic notes

Notes inserted automatically by the software in response to certain events as:

- connection of the instrument



	<ul style="list-style-type: none"> <li>• interruption of the connection of the instrument</li> <li>• start of the base</li> <li>• start of recording of raw data</li> <li>• interruption of recording of raw data</li> </ul>
<b>User notes</b>	texts, sketches and photo saved by the user

It's possible to visualize or hide notes.

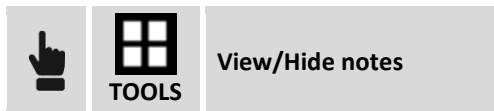

### Adding a note



First page allows to insert a descriptive text instead the second page allows to add a sketch or a photo.

### Moving GNSS base



After performing a post-processing of raw data acquired by the base and having obtained corrected coordinates of the same, it's possible to set the new coordinates of the base and obtain the updated coordinates of all points of the job.

Field	Description
<b>Base name</b>	List of base points present in the job. Select the base for which to insert the new coordinates
<b>Mode</b>	<p>Specify if they are inserted the new coordinates of the base or the moving values referring to previous values</p> <p>You can insert the new coordinates of the base in one of the following ways:</p> <ul style="list-style-type: none"> <li>- <b>New coordinates LLH:</b> activates the insertion of new values of longitude, latitude and height.</li> <li>- <b>Shifting values LLH:</b> activates the insertion of shifting values, than the previous position, of longitude, latitude and height.</li> <li>- <b>New coordinates ENZ:</b> activates the insertion of new values of coordinates East, North and elevation.</li> <li>- <b>Shifting values ENZ:</b> activates the insertion of shifting values, than the previous position, of East, North and elevation.</li> </ul>
<b>Latitude</b> <b>Longitude</b> <b>Elevation</b>	<b>E/N/Z</b> Insert the new coordinates of the base or the movement values.

At confirmation the coordinates of the base are changed with the new values and the coordinates of all points measured by the base are updated consequently.

## Measures report

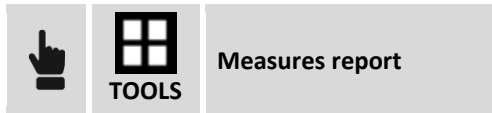

Generated a detailed report of all measures present in the job. The report can be obtained in ASCII, CSV for Excel, XML for Excel or PDF formats.

## Create surface from bathymetry

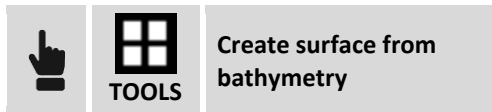

The command allows to create a triangles three-dimensional surface using the points of bathymetric sessions.

Field	Description
Name	Name of surface to create
Contour lines	Enables visualization of the contour lines on the surface.
Contour step	Equidistance to use to draw the curves.
Contour color	Color to use to draw the curves.

Select the bathymetric sessions and proceed with creation of the surface.

---

## Reference points

The **Reference points** table manages all topographic points with known coordinates and that can be therefore used in different situations as reference points and check points.



Functioning of the table is similar to the **Points** table.

---

## Survey codes

Survey codes allow to identify with precision every point and to automate many operations to complete the survey drawing. To the code it's possible to associate not only an extended description, but also a symbol and a layer; this way the points, basing on their associated code, are represented with a certain symbol and on a certain layer.

It's possible to define different libraries of codes and use them in different jobs; in every moment it's possible substituting the current library with a different one.

To every code it's possible to associate a GIS feature; the GIS feature is composed by a group of properties freely definable by the user; when a code or a GIS feature is associated to a point it's possible to integrate the point with the information corresponding to properties defined by the feature.



The table **Survey codes** reports the list of survey codes of the current library. For every code besides its value it's reported the symbol and the extended description.

**Note.** Codes libraries are saved in distinct files inside folder **X-PAD\\_Data\Codes** inside the software; files have XML extension.

### Creating a new code

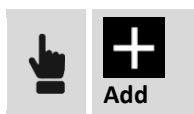

Data of the code are organized in pages.

Main data page	
<b>Code</b>	Short code
<b>Description</b>	Extended description
<b>Layer</b>	Layer associated to point
<b>Color by layer</b>	Specifies if to use the layer color for the drawing of the symbol of the point
<b>Color</b>	Color to use to draw the symbol if the point (if the layer color is not used)
<b>Symbol size</b>	Dimension of the symbol
<b>Drawing type</b>	<p>The code can identify the mode with which to represent graphically the object you are measuring. The types are:</p> <ul style="list-style-type: none"> <li>• <b>Single point:</b> the object measured is represented by a single position; for example a tree, an illumination pole.</li> <li>• <b>Line:</b> the object measured is represented by a polyline; for example a side of the road, a wall.</li> <li>• <b>Diagonal square:</b> the object measured is of squared shape and it's inserted measuring the points on the opposite end.</li> <li>• <b>Square center:</b> the object measured is of squared shape and it's inserted measuring the center and the middle point on a side</li> <li>• <b>Rectangle base:</b> the object measured is of rectangular shape and it's inserted measuring the points on the opposite end of the base and a point on the opposite side</li> <li>• <b>Rectangle center:</b> the object measured is of rectangular shape and it's inserted measuring the center, the middle point on a side and a third point on the other side</li> </ul>
<b>GIS feature</b>	<span style="background-color: #f4a460; padding: 2px 10px; border-radius: 5px;">GIS</span>

It's possible to associate to the code one of the GIS features present in the current job. It's possible to insert further information to points to which is associated a survey code to which, it self, is associated a GIS feature. These information are defined by the properties of the associated GIS feature.

#### Layer & Color page

<b>Layer</b>	Layer linked to point
<b>Color by layer</b>	Activates the use of layer color for drawing the point symbol.
<b>Color</b>	Sets the color to use to draw the point symbol (if the layer color is not used).
<b>Symbol size</b>	Sets the symbol size.

#### Symbol Page

Select symbol with which to draw the point to which the code has been associated.



Open Symbols manager

### Editing a code



Select code on table and select the **Edit** item from the appearing menu. The content of the window is the same still seen for creation of a new code.

### Deleting a code

Select code on table and select the **Delete** item to delete the selected code.

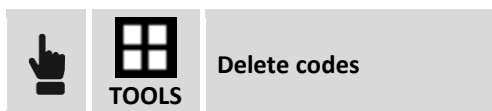
### Deleting a group of codes



Step	Description
1	Select codes to delete
2	Hit  to select or deselect all points of the list.
3	 to proceed deleting codes

### Creating a new library

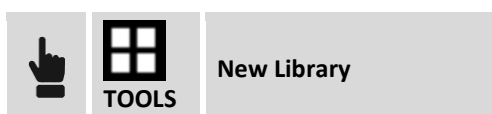

Assign a name to the library to create. The table present itself empty and ready to insert new codes.



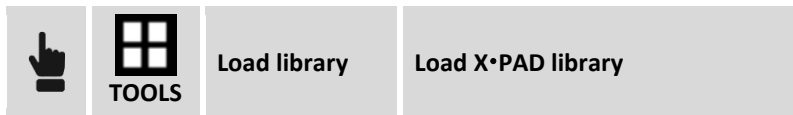

### Loading an existing library



Select file corresponding to library to load.

### Importing a list of codes from ASCII file



Step	Description
1	Select text file to load
2	Choose the desired importing scheme or choose * <b>Custom</b> * to proceed to creation of your own scheme.
3	Set the separation character (in case of Custom scheme)
4	Set the number of lines composing the header of the file and that have hence not to be imported.
5	
6	In case of <b>Custom</b> scheme it's possible to decide which fields are present in the file and in which order.
7	
8	A preview of importing result it's visualized
9	
10	Assign a name to importing scheme so that you can use it in next importations.
11	 to start importation

**Note.** Schemes of importation/exportation are saved on file with **PSC** extension in the **X-PAD\\_Data\Schemes** folder of the software.

### Importing a codes list from GeoMapper file

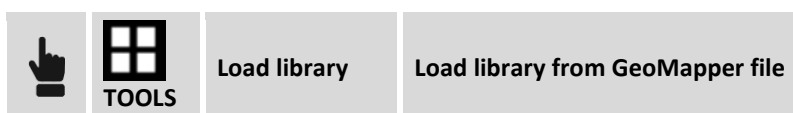

Select the GeoMapper file containing the codes to import.

### Importing a codes list from SCC file

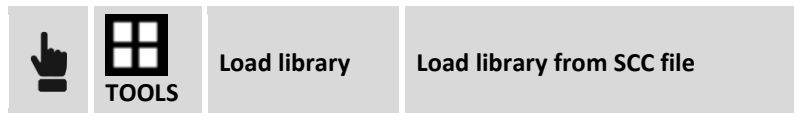

Select the SCC file containing the codes to import.

### Importing a codes list from LandXML file



Specify if to add codes to the current library or if to create a new library; select then the LandXML file containing the codes to import.

### Exporting current library

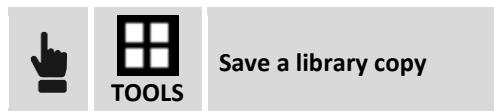

Assign a name with which to save current library.

### Exporting current library as default codes library



The current library is saved as default codes library. The new jobs will use the default codes library.

### Managing GIS data



Access to table of GIS features that can be associated to survey codes.

---

## Symbols manager

The symbols manager allows to insert and to delete symbols associated to points codes.



### Deleting a symbol

Select the symbol and select item **Delete**.

## Importing new symbols

It's possible to import new symbols from blocks of a DXF file.



Select the DXF file containing blocks to import. For every block present in the DXF file it's calculated the maximum dimension and a corresponding scale factor it's applied so it can be represented as a symbol.

**Warning.** Blocks to use to become symbols must contain the base entities as lines, polylines, arcs and circles and must be of little dimension.

## GIS features



### GIS

A GIS feature is composed by a group of properties the values of which allow to describe in complete manner an element of the territory measured. The GIS features are used hence to allow measuring, not only the positions of the elements of the territory, but also further descriptive data with the scope to create a GIS system.

Example of GIS features:



GIS feature	Attribute name	Attribute type	Constraints
<b>Well</b>	Type	List of values	
	Depth	Floating-point value	Obligatory
	Number of connections	Integer value	Minimum 1 maximum 4
	Maintenance	True/False	
<b>Tree</b>	Type	List of values	
	Elevation	Floating-point value	Obligatory
	Diameter	Floating-point value	Obligatory
	To cut	True/False	

The user can build his own library of GIS feature and to define, for every feature, the corresponding attributes; every GIS feature can be associated to a survey code; during survey, when you save the point, the software checks the survey code associated to the point: if a GIS feature is associated to the survey code, it will appear so a window allowing to fill the corresponding attributes.

All these information associated to points can be exported in different ways.

## Creating a new GIS feature



GIS feature	
Name	Name of the GIS feature
Attributes	List of attributes defined by the feature
	Allows to create a new attribute
	Moves the attribute in previous position
	Moves the attribute in next position

To edit a GIS attribute select it from the table and chose the **Edit** item from the appearing menu. The content of the window is the same still seen for creation of a new attribute.

To delete a GIS attribute select it from the table and chose **Delete** item from the appearing menu.

## Adding a GIS attribute



GIS attribute	
Name	Name of the attribute
Type	Type of value of the attribute: <b>Text</b> : alpha-numeric text <b>Integer number</b> <b>Real number</b> <b>Yes/No</b> <b>Title</b> : it's not an attribute but the title of the group of the following attributes
Prompt	Text of request of the attribute
Default value	Value to purpose as default
List	List of values
Fixed list	When the option is active the value of the attribute can be chosen only from the list of values and can't be inserted by the user
Mode	Mode of request of value: <b>Active</b> : normal request <b>Read only</b> : the attribute is not editable <b>Hidden</b> : the attribute is hidden and is not visualized
Obligatory	Activating this option it's necessary to assign a value to the attribute and it can't be left without a value



### Saving GIS features



Exports the GIS features of the current job on an external library in order to use it in other jobs.

### Loading GIS features

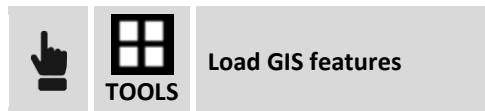

Allows to load in the current job a library of GIS features previously exported from another job.

---

## Coordinate system

The coordinate system allows to define different parameters and methods of calculation including the ones to use for the transformation of the geographic coordinates obtained from GPS instrument.

**Pay attention.** Modification of the coordinate systems parameters determinates an automatic re-calculation of the coordinates of the GPS points present in the job; this way it's possible in every moment to change the system obtaining the coordinates of the point in the new system.

---

## Cartographic system

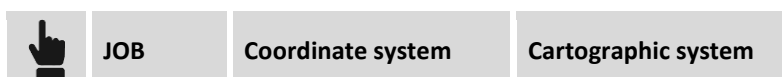

Setting the cartographic system it's necessary if coordinates of the points are referred to a system defined by a reference projection, datum and ellipsoid and by some transformation parameters. The cartographic system can be used both for calculation of the geographic coordinates of GPS instrument both for calculation of the scale factor to apply to distances measured with total station. In definition of the cartographic system it's possible to choose one among predefined systems or to define in complete way your own system with all the parameters.

Field	Description
Name	Name to assign to the system
Projection	Cartographic projection to use
Datum	Datum to use to pass from WGS84 ellipsoid and the cartographic system ellipsoid. Click on field to access to window reporting the list of preset datum and of datum created by the user.
Ellipsoid	Ellipsoid of the cartographic system. Click on field to access to window reporting the list of preset datum and of datum created by the user.

Field	Description
Origin Latitude Origin Longitude False East False North Scale	Parameters of the coordinate system

In order the cartographic system is used for the transformation of the GPS coordinates it's necessary to specify that you want to use it in the command **GPS localization**.

### Tools of cartographic system

The program has specific tools to load a predefined system, save a system as default and delete the current cartographic system.



## Loading a predefined system

The software has a wide list of coordinate systems used in different countries and immediately usable.



It's proposed the list of the systems available among which to choose the desired one. The systems are organized by country but it's also available a **\*\* USER \*\*** in which are saved systems created by the user.

## Saving a system as predefined

Current system can be saved in the **\*\* USER \*\*** group of the predefined systems to be used also in other jobs.

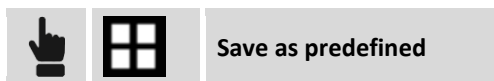

## Deleting current cartographic system

Command allows to cancel the setting of the current cartographic system.

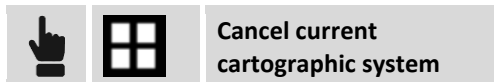

---

## GNSS localization



With this command you define the method to use for transformation of the GPS coordinates in plane coordinates and vice-versa; the method distinguishes the calculation to use for transformation of the coordinates from the method to use for calculation of the elevations.

In the absence of a GPS localization only the geographic coordinates of the points are recorded but it's not possible their visualization in the graphic window.

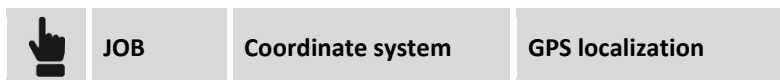



Systems	Description
No system	No coordinate system is applied
Local - Single point	It's created a system based on a local projection referred to an origin point.
Local – Site calibration	It's created a local system based on couples of points for which they are known both the geographic coordinate both the corresponding local plane coordinate.
Reference axis <b>BUILD EXTENSION</b>	It's created a local system based on measure of origin point and measure of a second point, which sets the direction of axis.





<b>Cartographic system</b>	The passing from geographic coordinates and plane coordinates comes through the use of the cartographic system explained in previous paragraph.
----------------------------	---

### Local system – single point

Step	Description
1	Choose the option <b>Local – single point</b>
2	Hit <b>Details</b> .
3	Specify the geographic coordinates of the reference point of the system; if a point is still present with desired coordinates it's possible to recall it typing its name, selecting it from the graphic or from the tables. It's possible to acquire the current position hitting the button <b>Measure</b> ; it's opened a window where it's possible to specify the elevation of the antenna and to acquire position.
4	 <b>Next</b>
5	Specify the local coordinates corresponding to the reference point; if it's still present a point with desired coordinates it's possible to recall it typing its name, selecting it from the graphic or from the tables.
6	 <b>Next</b>
7	Procedure follows with request of the mode of calculation to use for elevations.

### Local system – Site calibration

Step	Description																
1	Choose the option <b>Local – Site calibration</b>																
2	Hit <b>Details</b> .																
3	<p>The table reports the couples of points to use for calculation of the local system. For every couple it's possible to decide if to use data for calculation of the plane transformation and for the elevation transformation; basing on the available information the software will choose automatically the method to use for plane coordinate calculation. For every couple are also reported the deviations calculated regarding the coordinates and elevations.</p> <table border="1" data-bbox="443 1715 1217 1872"> <tr> <td><input checked="" type="checkbox"/></td> <td><b>H</b> 0.002m</td> <td><b>1 - 100a</b></td> <td></td> </tr> <tr> <td></td> <td></td> <td>Lat.</td> <td>N 45°17'11.3864"</td> </tr> <tr> <td><input checked="" type="checkbox"/></td> <td><b>V</b> 0.014m</td> <td>Lng.</td> <td>E 9°28'26.0826"</td> </tr> <tr> <td></td> <td></td> <td>H</td> <td>118.047m</td> </tr> </table>	<input checked="" type="checkbox"/>	<b>H</b> 0.002m	<b>1 - 100a</b>				Lat.	N 45°17'11.3864"	<input checked="" type="checkbox"/>	<b>V</b> 0.014m	Lng.	E 9°28'26.0826"			H	118.047m
<input checked="" type="checkbox"/>	<b>H</b> 0.002m	<b>1 - 100a</b>															
		Lat.	N 45°17'11.3864"														
<input checked="" type="checkbox"/>	<b>V</b> 0.014m	Lng.	E 9°28'26.0826"														
		H	118.047m														
4	 <b>New</b> to add a new couple of points																
5	Specify the geographic coordinates of the reference point of the system; if it's still present a point with desired coordinates it's possible to recall it typing its name, selecting																

	it from the graphic or from the tables. It's possible to acquire the current position hitting the button <b>Measure</b> ; it's opened a window where it's possible to specify the elevation of the antenna and to acquire position.
6	 <b>Next</b>
7	Specify the local coordinates corresponding to the reference point; if it's still present a point with desired coordinates it's possible to recall it typing its name, selecting it from the graphic or from the tables.
8	Continue adding further points
9	Verify deviations calculated for every point and the scale factor visualized in the lower part of the window. <div style="border: 1px solid orange; padding: 10px; text-align: center; margin: 10px auto; width: fit-content;">Calculation completed. Scale factor: 1.0000</div>
10	
11	Procedure follows with request of the mode of calculation to use for elevations.

In the lower part of the window is visualized the method of calculation chosen by the software basing on the number of localization points present. Clicking on the panel it's possible to set the scale application mode.

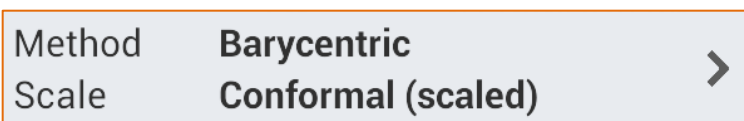

Calculation	Description
<b>Rigid body (unscaled)</b>	No scale factor is applied; the original distances between measured points are maintained.
<b>Conformal (scaled)</b>	A scale factor it's calculated and applied to allow an adaptation of the measured points to reference points.

#### Tools of Local system – Site calibration

Inside menu  **Tools** they are present commands for importation allowing to compile directly the list of calibration points:

Command	Description
<b>Import from reference points</b>	Imports all calibration points which have defined both the cartographic coordinates (north, east, elevation) both the geographic coordinates (latitude, longitude, height).
<b>Import FieldGenius RAW file</b>	Imports the calibration system defined in a job created with software FieldGenius; it's requested the RAW file of FieldGenius.
<b>Export for Topcon Machine Control</b>	Exports the the calibration system to Topcon Machine Control system.

<b>Export SurvCE (LOC)</b>	Exports the calibration system for the SurvCE program in LOC format.
<b>Delete all points</b>	Delete all points of the calibration system.

## Reference Axis



The software creates a local system based on measure of origin point and measure of a second point, which sets the direction of axis.

Step	Description
1	Choose the option <b>Reference axis</b>
2	Hit <b>Details</b> .
3	Enter the coordinates of origin point of the reference axis.
4	Hit <b>Measure</b> to perform the reference point measurement, or <b>Select</b> to choose the coordinates from the CAD window.
5	Hit <b>Measure</b> to perform the origin point measurement of reference axis.
6	Hit <b>Measure</b> to perform measurement of point that defines the direction of reference axis.
7	The procedure continues with the request for the calculation method to be used for elevation.
8	Hit <b>Accept</b> .

## Cartographic system

Before setting use of the cartographic system it's necessary to proceed with related setting. See previous paragraph **Cartographic system**.

Step	Description
1	Choose option <b>Cartographic system</b>
2	Hit <b>Details</b> .
3	They are re-proposed the parameters of current cartographic system. On X-PAD for Windows Mobile it's possible to choose the cartographic system among the preset systems.
4	 <b>Next</b>
5	Procedure follows with request of the mode of calculation to use for elevations.

## Calculation of elevations

After defining the mode of calculation of the coordinates the procedure allows to set the mode to use for elevations calculation.

Systems	Description
<b>WGS84 ellipsoid elevation</b>	The elevation on WGS84 ellipsoid is maintained
<b>Reference ellipsoid elevation</b>	It's assigned the elevation referred to the reference ellipsoid of the cartographic system (only if a cartographic system has been set)
<b>Local system elevation</b>	It's calculated the elevation basing on local system data (only if a local system has been set)
<b>Geoid</b>	In the list are visualized the geoid models available that have been installed with localization packages. The elevation is calculated through interpolation on the selected geoid model.
<b>Offset</b>	Allows you to set a value to be added to the elevation calculated using one of the above methods.

### Tools of Coordinate System page



#### Loading a coordinate system

A coordinate system previously saved from another JOB can be loaded and used in the current job.

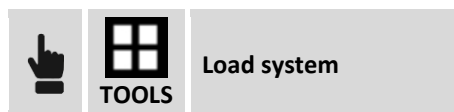

Select file of the coordinate system to load.

#### Exporting current coordinate system as default system

Parameters and settings of a coordinate system can be exported as default system; all new jobs that will be created they use directly the default coordinate system.

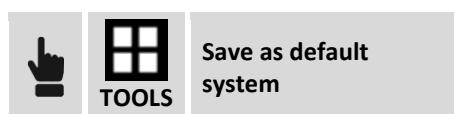

#### Exporting current coordinate system as site default system

Parameters and settings of a coordinate system can be exported as site default system; all new jobs of the site that will be created they will use directly the default coordinate system.

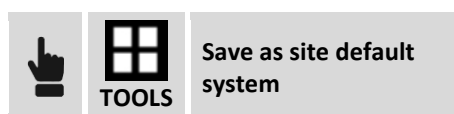

#### Exporting current coordinate system

Parameters and settings of a coordinate system can be saved in an external file to be used in other jobs relate to the same zone.



Indicate the name to assign to the file and to the folder where to save.

**Note.** Files containing the definition of a coordinate system have PCS extension.

### Report of current coordinate system

Settings of the current coordinates system can be exported in a report in ASCII, Excel (CSV or HTML) and PDF format.

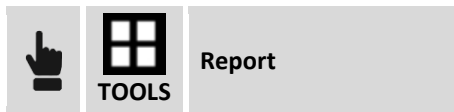

## TPS coefficients

TPS

TPS coefficients allow to define parameters for the reduction of the distances measured with the total station to the sea level and at the cartographic plane.

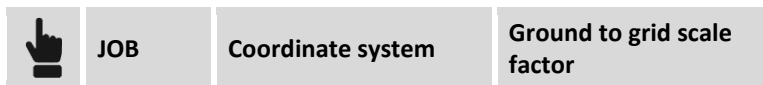

Field	Description
To sea level	Application of the reduction of the distances at the sea level basing on the set average elevation
Average elevation	Average elevation for calculation of the reduction of the distances
To cartographic plane	Application of the reduction of the distances at the cartographic plane
Scale factor	<p>Scale factor for reduction at the cartographic plane; the scale factor can be inserted manually or calculated basing on a coordinate; it's necessary having set a cartographic system.</p> <p><b>None:</b> the software does not apply the scale factor.</p> <p><b>Global scale factor:</b> the scale factor to reduce the distance to grid coordinate system; the scale factor can be inserted manually or can be calculated based on one coordinate; you must set a cartographic system. This factor will be applied to all TPS measures.</p> <p><b>Automatic scale factor:</b> the scale factor to reduce the distance to grid coordinate system; the scale factor will be calculated for each TPS measurement using the average position between the measured point position and the total station position. it's necessary having set a cartographic system.</p>

## Base position adjustment

This function allows to insert or calculate a correction factor of the base position so that the rover has exact coordinates. It's possible for example to start the base on an unknown position and then go with



the rover receiver on a point of known coordinates and measure it; the difference between known position and position provided by the base represent the correction (in latitude, longitude and height) that must be applied continuously to coordinates of the rover receiver.

	<b>JOB</b>	<b>Coordinate system</b>	<b>Base position adjustment</b>
---	------------	--------------------------	---------------------------------

Field	Description
<b>Δ latitude</b> <b>Δ longitude</b> <b>Δ elevation</b>	Correction in geographic coordinates to apply to coordinates received from the base to have the correct coordinates (as if the base were located on a known point).

Press button **Measure** to measure with Rover receiver a point of which they are known the coordinates in the defined coordinates system; specify then the local coordinates corresponding to reference point; if a point with desired coordinates is still present it's possible to recall it typing its name, selecting it on graphic or on tables.

The difference between the coordinates of the point provided by the base and the coordinates calculated from the known point is right the difference which will be saved and applied automatic to coordinates of the Rover receiver.

---

## CAD

The CAD of **X•PAD** it's a fundamental element of the entire solution allowing to use the software not only for survey and stakeout but also as a true tool helping in every situation.

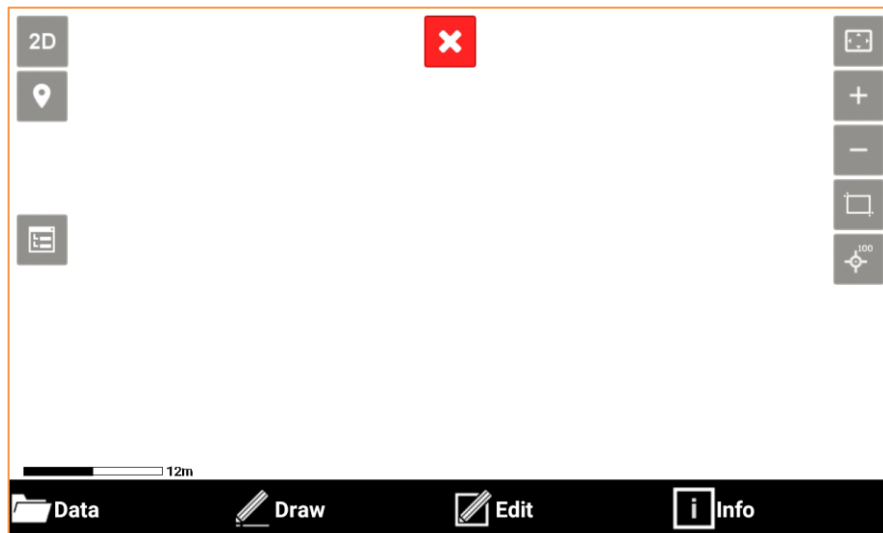

The window present a tool bar in the lower part of the window from which you access to all the CAD functions.



---

### Closing CAD

Clicking on the graphic visualization space they appear the buttons for visualization and the button for closing the CAD window.



---

### Control of the visualization

The buttons and commands for displaying the drawing are activated by clicking in the graphical windows of the drawing display.







Visualization commands		
	<b>Zoom All</b>	Visualization of all the drawing elements
	<b>Zoom Window</b>	Allows to specify the visualization window through indication of the opposite angles
	<b>Zoom In</b>	Bring near the point of view enlarging the visualization
	<b>Zoom Out</b>	Bring far the point of view reducing the visualization
	<b>Points Labels</b>	Enable/disable point data display.
	<b>Working area</b>	The icon notifies that the drawing extension is too large to appropriate display all elements and allows you to define the working area.
	<b>Pan</b>	The shifting of the view is always active; click on graphic area and drag the view.
	 <b>Pinch out</b>	Click on the graphics area using two fingers and enlarge them to Zoom In.
	 <b>Pinch in</b>	Click on the graphics area using two fingers and bring them closer to Zoom Out.

## How to set the working area

When the drawing extension is too large to be displaying the items correctly the icon will appear . By clicking on the icon, you can set the working area, that is the area on which you want to work. When a working area is stored, the software will use it as the default view for the CAD and SURVEY job window. If a working area is defined, the command **Zoom All** shows the whole defined working area. You can create a working area in the following ways:

Set the working area			
1			Allows you to directly set the working area.
2			Perform the view adjustment.
3			Save the working area.

Set the working area			
1			Allows direct access to the definition of the working area.

2			Select <b>Define working area</b> . If you have already defined a working area, you can create a new one.
3			Perform the view adjustment.
4			Save the working area.

Then the software notifies that the working area has been defined.









### How to erase the working area

You can cancel the stored working area. This allows the **Zoom All** command to show the entire drawing area.



## Display mode

You can set the display mode of the CAD by clicking on the active view mode button in the window.



Set the working area			
		2D	Enables 2D drawing display.
		3D	Enables 3D drawing display.
		Map	Enables 2D display of a reference map.
		Augmented reality	Enables the use of augmented reality.

### 3D View

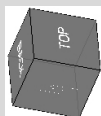

Activates 3D visualization of the drawing.

Commands of visualization		
	<b>Change view</b>	Click on graphic area and drag to change the point of view.
	<b>Views</b>	Allows to select one of the predefined views using the faces of the cube.

	<b>Pinch out</b>	Click on the graphics area using two fingers and enlarge them to Zoom In.
	<b>Pinch in</b>	Click on the graphics area using two fingers and bring them closer to Zoom Out.

### Use of the maps

X-PAD allows you to use different types of maps as a basis references for the survey and stakeout activities so you can see all of your data overlapped to a map. You can choose between Google maps, Bing, OpenStreet and many others. On the main maps you may overlap the WMS (Web Map Service) maps, provided by government agencies or other offices, that represent additional elements typical of the area and specifically interesting for your surveying activities.



### Select maps to visualize



In tab **ON-LINE MAPS** it appears a list of preset maps; choose the desired map or choose **NONE** if you want no main map but only WMS maps.

In tab **ON-LINE WMS** it's visualized the list of WMS maps defined; it's possible to make visible more than one WMS map.

### WMS Maps (Web Map Server)

In addition to the preset maps it's possible to create connections to WMS maps.



Field	Description
<b>Name</b>	Name to assign to WMS map
<b>Url</b>	Address of WMS map
<b>User</b>	Username for accessing to the WMS service, if required by the WMS
<b>Password</b>	Password for accessing to the WMS service, if required by the WMS
<b>Layer</b>	Select layer to visualize among the ones available in the server
<b>Projection</b>	Shows the projection system of WMS service

### Creating maps to use in off-line mode

Before proceeding to save of an off-line map, make visible the reference map and eventually the WMS maps.

Then set view in order to include the zone you are interested in, to save for off-line mode use.

Field	Description
Map name	Name to assign to off-line map
Zoom Min	Minimum level zoom
Zoom Max	Maximum level zoom
Tiles count	Basing on the limits of the zone and of the zoom it's calculated the number of tiles to be downloaded

When finished with download of all tiles the off-line map is available and can be used.

**Warning.** Number of tiles can be great and request much time to complete download and take much space on the disk. It's appropriate so not to exceed in the extension of the zone to save and to save only the necessary levels of zoom.

### Using off-line mode maps

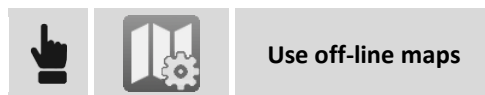

Select among the off-line maps available the ones to visualize.

### Saving the current view as image



Current view is saved as image file.

### Augmented reality



It's activated the photo camera of the device and, basing on GPS position and on parameters of inclination and direction of device, it's visualized the drawing in overlap to pictures coming from camera.



## GPS navigation mode

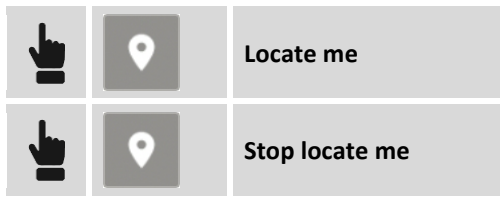



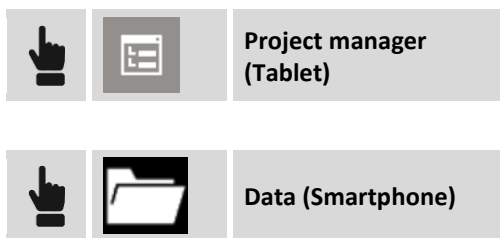

Visualizes current position on drawing; it's necessary having set a coordinate system. For visualization of the current position the software can use the connected receiver or the device internal GPS. Current position is kept inside the graphic view.

---

## Project manager



The Project Manager is a panel that allows access to the management and modification of the several types of entities that can be displayed in the CAD window.

Project manager		
	<b>Layer</b>	Access the Layers management and graphical properties of drawing elements.
	<b>External reference</b>	Access the external reference management.
	<b>Surfaces</b>	Access the management of display and properties of the surfaces.
	<b>BIM entities</b>	Access the management of the display of the entities present in the files type IFC.

## Layers management



The window manages the layers of drawing.

### Set the current layer



The current layer is marked by  symbol. To set current layer it's sufficient to select the corresponding symbol .

### Creating a new layer



Hit . Then insert the name of the new layer and push **OK**.

### Making visible/invisible a layer

Visible layers are marked by symbol  instead layers non visible are marked by symbol . To change the visibility status of a layer click at symbol.

### Making visible/invisible all the layer



### Change color/linetype of a layer

To change color to a layer it's sufficient to click at the panel of the color to access to the window with settings of colors;

To change linetype to a layer click at name of the linetype to access to the window with settings of linetypes.

### Deleting unused layers

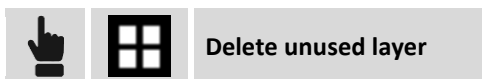

The command allows to automatically delete all the layers those have no drawing element.

### Deleting layers

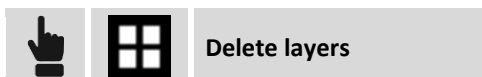

The command allows to delete the selected layers and all connected drawing entities.

### External reference



For information on importing DXF/DWG files, X-PAD documents, IFC files and raster maps as external references refer to the **External References** chapter.

### Surfaces







For information on surface management please refer to the chapter **Surfaces and Volumes**.

## BIM items

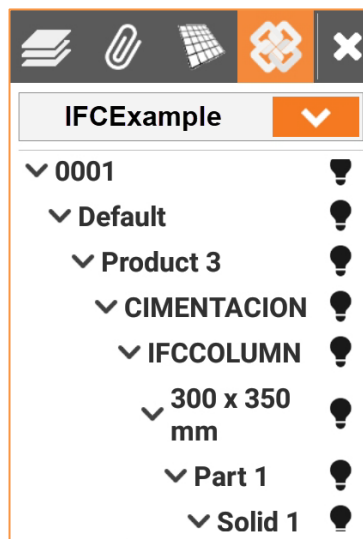

The Industries Foundation Classes (IFC) format is the reference for the BIM methodology. This type of file has a data structure divided into classes, each class contains objects. Using an IFC file as an external reference makes all the classes and objects in the file available in the CAD window. In this panel of Project Manager you can change for each IFC file linked to change the display state of a class or objects.



It is possible show or hide items by clicking at the symbol  or symbol .

From the table you can change the display parameters by clicking .

---

## CAD setup

Functioning of CAD is ruled by a parameters and options fully customizable by the operator and editable in every moment.



## Survey

The page allows to set survey data to visualize in graphic window.

### Survey display filters

Field	Description
Topographic points	Turns on/off the display of stored points.

<b>Reference points</b>	Turns on/off the display of Reference points.
<b>Stakeout points</b>	Turns on/off the display of stakeout points.
<b>Collaborative points</b>	Turns on/off the display of X-Live points.
<b>Measure lines</b>	Turns on/off the display of measure lines.
<b>Drawing by codes</b>	Turns on/off the display of drawing by codes.
<b>Parcels</b>	Turns on/off the display of parcels

## Points

The page allows to set information of topographic points to visualize in graphic window.

### Points display filters

Field	Description
<b>Point name</b>	Turns on/off the display of the point name.
<b>Point elevation</b>	Turns on/off the display of the point elevation.
<b>Point code</b>	Turns on/off the display of the point code.
<b>Point description</b>	Turns on/off the display of the point description.
<b>Point symbol</b>	Turns on/off the display of the point symbol.

### Points symbol and label size

Field	Description
<b>Label with background</b>	Turns on/off the display of the label background.
<b>Point size</b>	Allows to set the size used to display the text of labels.
<b>Auto size label in 3D</b>	Turns on/off automatic text size management when 3D display is active. If the option is active, the size of the text changes depending on the distance. The closest texts will be displayed with a larger size than the furthest ones.

## CAD

### CAD display filter

Field	Description
<b>Main drawing</b>	Turns on/off the display of drawing elements.
<b>External reference</b>	Turns on/off the display of the elements stored in the external reference.
<b>Use linetypes</b>	Turns on/off the display of the linetype associated with the drawing elements .
<b>Line double thickness</b>	Turns on/off the display of drawing elements with a doubled thickness.
<b>Mono color drawing</b>	Turns on/off the display of drawing elements colors.

<b>Autocenter in drawing</b>	Turns on/off the autocenter of the drawing. During drawing operations, each time a CAD location is set, it is shown in the center of the graphical window.
<b>Grid</b>	Turns on/off the display of the grid in the CAD window.
<b>Grid step</b>	Sets the steps of the grid.

### AR settings

Field	Description
<b>Height from ground</b>	Sets the height of the point of view, when augmented reality display mode is active.
<b>Radar</b>	Turns on the display of the bottom right panel representing the plan view.

## Importing DWG/DXF files



DWG/DXF In

For information on importation of DXF files refer to chapter **Importing data**.

## Exporting DXF files



DXF Out

For information on importation of DXF files refer to chapter **Exporting data**.

## Object snap

When is active a drawing or editing command it's possible to select the object snap; the object snap allow to identify precise positions on drawing objects.

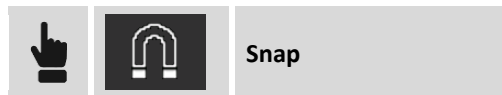

Snap

Type	Point identified
<b>Extreme</b>	End point of objects as lines and arcs.
<b>Medium</b>	Medium point of objects as lines and arcs.
<b>Perpendicular</b>	Point on normal of a line, arch, circle object referring to reference point.
<b>Intersection</b>	Intersection point between objects as lines and arcs.
<b>Node</b>	Point of insertion of an object topographic point.
<b>Center</b>	Center of an arc or circle.

**Tangent**

Point of tangency of an arc or circle referring to reference point.

**Note.** If no object snap has been set it's possible to draw freely indicating every position.**Working with object snap**

At request of a point by a command of the CAD click on interested drawing object and near the point to identify; it will be visualized a symbol in the identified position. The symbol represent the type of snap used to identify the position.

**Snap to topographic points**

The identification of the coordinate of a topographic point can be obtained using the snap **NODE** or typing, at request of the position of the point, the name of the same topographic point.

**Drawing functions**

Drawing commands allow to add new objects to drawing.



Object	Description
<b>Topographic point</b>	Indicate the name of the point and then the position of insertion
<b>Lines and polylines</b>	Indicate points composing the object line or polyline
<b>Arc</b>	Indicate the three points composing the arc
<b>Circle</b>	Indicate the center of the circle and specify the value of the radius or indicate the point of passage
<b>Circle by 2 points</b>	Indicate the two points that identify the diameter of the circle
<b>Circle by 3 points</b>	Indicate the three points composing the circle
<b>Parcel</b>	Specify vertexes of the parcel. To close a parcel indicate again first vertex. The corners of the parcel must be topographic points.
<b>Text</b>	Specify text to insert, dimensions and rotation angle then specify the insert position.
<b>Layout</b>	Draws consecutive elements setting distances and angles from a starting point.
<b>BIM Tools</b> <b>BIM</b>	Allows you to perform several operations if you have loaded surfaces from an IFC file.

For a precision drawing use the object snap or answer with the name of the point to which to link the vertex of the line.

**Insert drawing coordinate**

You can draw a line, polyline, arc, and circle in the following ways:

- **Selection in the CAD window:** select the points those are the vertexes of the element or their position in the window.
- **Entering point name:** enter the name of the stored point that corresponds to the vertex of the element in the box below the CAD window.
- **Select point:** press > in the box below the CAD window to access the insertion options.

### Options of point selection



You can use one of the following options to set the vertices of the drawing element

Object	Description
<b>Topographic Points</b>	Allows you to select the vertices of the element from the topographic points table.
<b>Reference Points</b>	Allows you to select the vertices of the element from the reference points table.
<b>Point sequency (only for line and polyline)</b>	Allows you to set a sequence of points to join by selecting the first and last point of the element. To join the points you can select: <ul style="list-style-type: none"> <li>• <b>Incremental:</b> joins the points according to the numerical part of the name.</li> <li>• <b>Sequential:</b> join the points using the order of the topographical point table.</li> </ul>
<b>Coordinates</b>	Allow the input of the vertexes coordinates. The coordinates can be <b>Absolute, Relative</b> or <b>Polar</b> .

### Drawing a layout



The command allows to draw lines and arcs starting from a point of origin.

### Drawing mode

The command prompts you to select the items to insert.

Field	Description
<b>Points and lines</b>	Enables the draw of lines, arcs, and points.
<b>Only points</b>	Activates the creation of points only.
<b>Only lines</b>	Enables the draw of lines only.
<b>Elevation</b>	Enables the insertion of the elevation for made items. If it is disabled, the program assigns the start point elevation to the items that are created.

Then press **OK**

Field	Description
<b>Draw</b>	Choose the drawing element to create to calculate the second point position. You can use a line or an arc.
<b>Point</b>	Allows you to set the insertion point in the following ways: <ul style="list-style-type: none"> <li>• Select the point in the CAD windows</li> <li>• By clicking in the box insert the point name.</li> <li>• Clicking on &gt; allows you to select the point from the topographic point table or from the reference point tables.</li> </ul>
<b>Distance</b>	Sets the distance from the starting point to draw the line. You can enter the value in one of the following ways: <ul style="list-style-type: none"> <li>• input the value in the box.</li> <li>• Click &gt; select <b>By two points</b> to set the value of distance using the distance between the two selected point.</li> </ul>
<b>Azimuth/Direction</b>	Set the azimuth. You can enter the value in one of the following ways: <ul style="list-style-type: none"> <li>• input the value in the box.</li> <li>• Press <b>Up/Down</b> to increase or decrease the value based on the increment value set.</li> <li>• Click &gt; select <b>By two points</b> to set the azimuth value based on angle between the two selected points.</li> </ul>
<b>Angle</b>	Sets the angular development value of the arc.
<b>Increment</b>	Sets the value the software adds or subtracts in the azimuth input, when using <b>Up/Down</b> .
<b>Radius</b>	Sets the arc radius value and direction using → and ← .
<b>Elevation</b>	Set the value of the elevation in the following ways: <ul style="list-style-type: none"> <li>• Input the value in the box.</li> <li>• Press &gt; to choose the elevation input mode.</li> </ul>

### Example of procedure

To draw a layout similar the following:

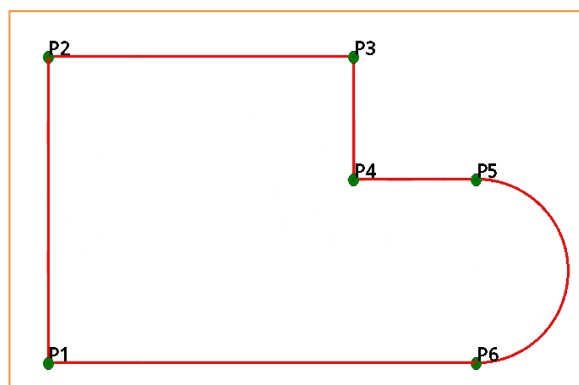

You can follow the steps described:

Step	Description
<b>Line P1 - P2</b>	
1	Measure or input the coordinate of the point P1.

2	Set <b>Draw: Line.</b>
3	Set <b>Point: P1.</b>
4	Set <b>Distance: 5 m</b>
5	Set <b>Azimuth: 0 c</b>
6	Push <b>Add point.</b>
<b>Line P2 - P3</b>	
7	Set <b>Draw: Line.</b>
8	Set <b>Point: P2.</b>
9	Set <b>Distance: 8 m</b>
10	Set <b>Azimuth: 100 c</b>
11	Push <b>Add point.</b>
<b>Line P3 - P4</b>	
	Set <b>Draw: Line.</b>
	Set <b>Point: P3.</b>
	Set <b>Distance: 2 m</b>
	Set <b>Azimuth: 200 c</b>
	Push <b>Add point.</b>
<b>Line P4 – P5</b>	
	Set <b>Draw: Line.</b>
	Set <b>Point: P4.</b>
	Set <b>Distance: 2 m</b>
	Set <b>Azimuth: 100 c</b>
	Push <b>Add point.</b>
<b>Arc P5 – P6</b>	
	Set <b>Draw: Arc.</b>
	Set <b>Point: P5.</b>
	Set <b>Azimuth: 100 c</b>
	Set <b>Angle: 200 c</b>
	Set <b>Radius: 1.5 m</b>
	Push <b>Close</b> to draw the P5 – P1 line.

---

## Drawing tools for BIM

BIM



The commands allow to extract an IFC/BIM model points or polylines that can be used for subsequent operations.

Type	Identified point
<b>Point from surface</b>	Automatically insert topographic points at the vertices of selected 3D objects. It is required: <ul style="list-style-type: none"><li>• Select the surface.</li><li>• Push <b>OK</b>.</li><li>• Confirm the insertion of the points by clicking <b>OK</b>.</li><li>• Set the name of start point, the following points will have a progressive numbering.</li><li>• Set the layer.</li></ul>
<b>Lines from surface</b>	Automatically insert topographic points at the edges of selected 3D objects. It is required: <ul style="list-style-type: none"><li>• Select the surface.</li><li>• Push <b>OK</b>.</li><li>• Confirm the insertion of the items by clicking <b>OK</b>.</li><li>• Set the layer.</li></ul>
<b>Polylines from Horizontal section</b>	Allows you to extract the line of a horizontal section from the model. The model is cut using a horizontal plane created based on the specified elevation. The command can create section lines as well as points at the intersection of the plane with the IFC elements. It is required: <ul style="list-style-type: none"><li>• Input the elevation of the horizontal plane and push <b>OK</b>.</li><li>• Choose whether to add lines and choose the layer.</li><li>• Choose whether to add points.</li><li>• Push <b>OK</b>.</li><li>• The software shows the number of items that will be created, to confirm press <b>OK</b>.</li></ul>
<b>Polylines from Vertical section</b>	Allows you to extract the line of a vertical section from the model. The model is cut using a vertical plane created based on selected points. The command can create section lines as well as points at the intersection of the plane with the IFC elements. It is required: <ul style="list-style-type: none"><li>• Select the first point of the vertical cutting plane and press <b>OK</b>.</li><li>• Select the second point of the vertical cutting plane and press <b>OK</b>.</li><li>• Choose whether to add lines and choose the layer.</li><li>• Choose whether to add points.</li><li>• Push <b>OK</b>.</li><li>• The software shows the number of items that will be created, to confirm press <b>OK</b>.</li></ul>



---

## Editing and creation of new points functions

Editing commands allow to modify the drawing and to create new objects starting from existing ones.

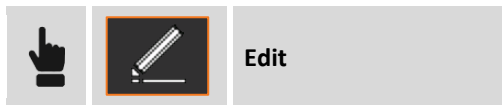

### Deleting objects

Command **Delete** allows to delete selected objects: select objects tracing a selection window.

### Distance intersection

Command **Int.2 Dist** calculates the position of a new topographic point located at a certain distance from two reference points.

Request	Description
<b>First point</b>	Indicate first reference point
<b>First distance</b>	Indicate the distance where it is the point to calculate referring to first reference point; it's possible to indicate a point that will be used to calculate the value of the distance referring to first point
<b>Second point</b>	Indicate second reference point
<b>Second distance</b>	Indicate the distance where it is the point to calculate referring to second reference point; it's possible to indicate a point that will be used to calculate the value of the distance referring to second point
<b>Select solution</b>	They are proposed the two possible solutions; select the desired solution

### Intersection

Command **Int.4 Points** calculates the position of a new topographic point that is on the intersection of two straight lines.

Request	Description
<b>First point</b>	Indicate first point of first straight line
<b>Second point</b>	Indicate second point of first straight line
<b>Third point</b>	Indicate first point of second straight line
<b>Fourth point</b>	Indicate second point of second straight line
<b>Insert point</b>	Confirm to proceed to insertion point

### Distance e offset

Command **Dst. & Offset** calculates position of a new topographic point referring to a reference object.

Request	Description
<b>Select object</b>	Select reference object referring to which to calculate the position of the point

<b>Distance</b>	Distance along reference object
<b>Offset</b>	Distance from reference object
<b>Select solution</b>	They are proposed the two possible solutions; select the desired solution

### Divide

Command **Divide** creates some topographic points along a reference object dividing it in a specific number of parts.

Request	Description
<b>Select object</b>	Select reference object on which to create the topographic points
<b>Number of parts</b>	Number of parts in which to divide the object
<b>Name first point</b>	Name of first topographic point to create

### Measure

Command **Measure** creates some topographic points along a reference object at constant distance.

Request	Description
<b>Select object</b>	Select reference object on which to create the topographic points
<b>Segment length</b>	Distance of insertion among points; setting a value of 0, they will be inserted points only in correspondence to vertexes of the polyline.
<b>Name first point</b>	Name of first topographic point to create

### Offset

Command **Offset** allows to create a new object parallel to reference object at a defined distance.

Request	Description
<b>Select object</b>	Select reference object
<b>Point or value</b>	Indicate point of passage or offset distance
<b>Select solution</b>	They are proposed the two possible solutions; select the desired solution
<b>Number of repetitions</b>	Number of consecutive offset to execute

### Lengthen

Command **Lengthen** allows to extend a line, a polyline or an arc of a defined length. Besides an object it's possible to indicate two points establishing direction toward which creating the new point.

Request	Description
<b>Distance</b>	Distance with which to lengthen an object
<b>Select object or 1° point</b>	Indicate object to lengthen or indicate the first point

### Second point

If a point has been indicated, it's requested to indicate the second point

## Explode

Command **Explode** allows to transform every selected polyline in the base element composing it; lines and circles. The original polyline is deleted and substituted by its base elements.

## Invert

Command **Invert** allows you to reverse the vertex order of a drawing element.



## Objects properties

Access the management of the graphical properties of the selected object (layer, color, linetype): select the object by drawing a selection window or click the object.

---

## Objects selection mode

You can change the object selection mode by pressing the active selection command.

Mode	Description
	Activates the window selection.
	Activates the selection of the object.

---

## Information commands

Information commands allow to obtain different information from drawing and from present objects.



## Coordinate of a point

Command **Coordinate** returns some information on indicated position.

Request	Description
Indicate point	Indicate position; they are visualized coordinates of indicated position.

## Distance between two points

Command **Distance** returns some information on distance between two points.

Request	Description
First point	Indicate first point
Second point	Indicate second point

The distance between two points is visualized and other information as azimuth, slope, etc.

### Distance point-object

Command **Dist.Object** returns some information on distance between a point and an object.

Request	Description
Reference point	Indicate reference point
Select object	Indicate the object referring to which to calculate distance
	It is visualized: <ul style="list-style-type: none"><li>- distance of point referring to object</li><li>- the chainage at which it is the projection of the point</li></ul> Button <b>Save</b> allows to create a point on projection of the point on the object.

### Angle

Command **Angle** returns the angle contained among three points.

Request	Description
Center angle	Indicate the center of the angle
First point	Indicate first point
Second point	Indicate second point
	It's visualized the angle included and the complementary angle

### Area

Command **Area** returns the area of polygon identified by a sequence of points.

Request	Description
First point	Indicate first point of the sequence
Next point	Indicate next point of the sequence
...	
	It's visualized the area, perimeter and center of gravity of the polygon

### List

Command **List** returns general information on selected object.

Request	Description
Select object	Indicate object

They are visualized also the object properties as layer, color, and line type; the properties can be edited.

## Report

Command **Report** creates a document that contains information about selected objects with data of length, area, number of vertices. You can export the document.

Request	Description
Select object	Choose the object
Report type	Choose the report type to export

## Find topographic point

Command **Find** brings in the center of the graphic window a topographic point.

Request	Description
Name point	Name of topographic point to find

## Longitudinal profile

Command **Longitudinal profile** visualizes the longitudinal profile of the selected polyline and returns some information about polyline.

Request	Description
Select polyline	Select polyline

---

## Toolbar contextual – Points

Selecting a topographic point, without any command active, it appears the following toolbar with contextual commands for the selected point.



Command	
Stakeout	Executes procedure of stakeout on selected point. For further information see chapter <b>Stakeout of points</b> .
ID	Opens the window allowing to visualize and edit the data of the point
Distance	Allows to calculates the distance from selected point referring to another point to indicate in graphic window
Distance Object	Allows to calculates the distance from selected point referring to a drawing object to indicate in graphic window
Delete	Delete selected point
Isolate	Turns off all layers except the layer of the selected object. To restore the previous situation, select an object and use the <b>Restore layers</b> command.

To restore the main bar it's sufficient to remove the selection to point clicking in every other part of the graphic window.

---

## Contextual toolbar – CAD objects

Selecting a drawing object, without any command active, it appears the following toolbar with contextual commands for the selected point.



Command	
Stakeout	Executes procedure of stakeout on selected point
ID	Returns information on selected object
Delete	Delete selected point
Isolate	Turns off all layers except the layer of selected object. To restore previous situation, select an object and use the command <b>Restore layers</b> .

To restore the main bar it's sufficient to remove the selection to point clicking in every other part of the graphic window.

## Instruments settings

Instruments settings allow to set the connection between device and the instruments but also to define parameters of operation of the same.

All parameters of connection and operation are organized in profiles: a profile contains the connection modes to instrument and all the related operation parameters; for the same instrument it's possible to create different profiles with different operation parameters and recall the desired one. Among all profiles present only one is the current profile and it's the one that will be used during the use of the software.

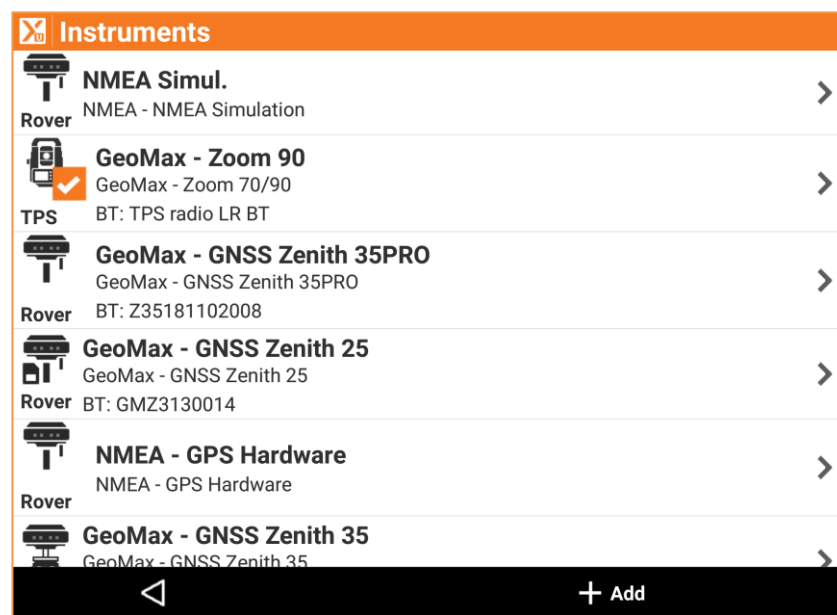

Icon	Description
	Current profile
	Rover GPS without RTK connection
	Rover GPS with GPRS RTK connection
	Rover GPS with Radio RTK connection
	Base GPS
	Total station

---

## Creation of a new GPS profile

GPS



Settings

GNSS & Total  
stations





GNSS Receiver (GPS)

Parameters and options requested are different according to the model of receiver and to the modes of operation. Parameters are organized in pages.

### Profile page

Field	Description
Profile name	Name to assign to profile
Mode	<b>GPS Rover:</b> receiver operates as Rover <b>GPS Base:</b> receiver operates as Base
Brand	Brand of receiver
Model	Model of receiver

### Device page

Field	Description
Device	Bluetooth Name of the instrument to connect. If the instrument does not appear in the list hit  and then  to start research.

### RTK page

Field	Description
Device	Type of device to use to send (base) and receive (rover) differential corrections. Possible options are: <b>None:</b> no RTK connection. Receiver operates in autonomous <b>Internal radio:</b> use of internal radio of receiver <b>Internal GPRS:</b> use of internal GPRS modem of receiver <b>External radio:</b> use of an external radio to receiver <b>External GPRS:</b> use of the GPRS modem of the device (controller) or the internet connection of the controller
Extra-safe	Enables and disables the Extra safe mode that's able to guarantee the maximum precision in coordinates; only for Zenith35.

### RTK – Radio page

Field	Description
Model	Model of the radio
Spacing	Spacing parameter - only for Zenith10/20
High Power	Radio with high power - only for Zenith10/20



<b>Channel</b>	Radio channel to use for transmission and receiving; base and rover must use the same channel and the same frequency. For Zenith10/20 it's possible to select item <b>Frequencies</b> from the list and set the frequencies to use for the different channels
<b>Format</b>	Format of corrections; base and rover must use the same data format.
<b>Use Base ID</b>	For <b>Rover</b> profile: sets the receiver to receive the corrections only from base identified by specified Base ID For <b>Base</b> profile: sets the name of the base
<b>Base ID</b>	Identification of the base

## RTK – GPRS page

Field	Description
<b>Provider</b>	Name of the phone provider providing GPRS service; select <b>Providers</b> item to define a new provider or to modify parameters of an existing provider. See next paragraph for managing Internet providers.
<b>Server</b>	Name of the permanent stations service ( <b>NTRIP</b> ) to connect to or name of the profile of <b>Direct call</b> ; select <b>NTRIP servers</b> item to define a new service or to modify parameters of an existing service. See next paragraph for managing <b>NTRIP</b> server or <b>Direct call</b> profiles.
<b>Mountpoint</b>	Name of mountpoint to use; it's possible to type the name or to see the list. Only if a server NTRIP has been set.
<b>Format</b>	Data format of corrections; it's necessary to set the same data format sent by permanent station (source).
<b>Type of network</b>	Type of network to use; only if a server NTRIP has been set and only for Zenith25 receiver.
<b>RTCM3.1 messages</b>	Activating this option the software is able to process some of the messages provided by RTCM3.1 protocol and particularly the ones referring to transformation parameters of the coordinate system and to correction to apply in coordinates calculation. To use correctly this option it's necessary that a correct cartographic system to which corrections and transformation parameters have to be applied has been set and used.
<b>RTCM3.1 mode</b>	RTCM3.1 messages can be used in following modes: <ul style="list-style-type: none"> <li>• <b>Horizontal &amp; Vertical</b>: correction and calculation both of coordinates both of elevations</li> <li>• <b>Horizontal only</b>: correction and calculation only of coordinates</li> <li>• <b>Vertical only</b>: correction and calculation only of elevations</li> </ul>
<b>Send GPUID to server</b>	Allows sending information of identification of the user to server to obtain the authorization to use some service.

## Parameters page

Field	Description
<b>Satellites Cut-off angle</b>	Minimum elevation, in degrees referring to horizon, to consider satellites usable; allows to avoid using satellites too low on the horizon increasing so precision.
<b>Use GLONASS</b>	Enables the use of satellites in the GLONASS constellation.

<b>Use BEIDOU</b>	Enables the use of satellites in the BeiDou (Compass) constellation.
<b>Use SBAS</b>	Enables the use of geostationary satellites SBAS. This option is available only if it has been set <b>None</b> as device RTK (page RTK). The receiver is able to receive correction directly from satellites SBAS and improve quality of the position without any type of RTK connection (radio or GPRS).
<b>Position update freq.</b>	Frequency with which the value of the position it's updates. Especially for tracking operations we recommend a value of <b>5 times per second</b> .
<b>Extra-safe</b>	Enables Extra safe mode that ensures maximum precision in coordinate calculation; only for Zenith35.

### Antenna page

Field	Description
<b>Model</b>	Type of antenna of receiver
<b>Elevation</b>	Default receiver antenna elevation

### Managing of profiles of internet provider

Provider is the manager providing the service of data traffic GPRS. Defining a provider requested data are the following:

Field	Description
<b>Name</b>	Description (name) of provider
<b>APN Server</b>	Name of the access point for GRPS and UMTS nets. Example: web.omnitel.it
<b>User ID</b>	Set UserID to access the service (only if access is protected by UserID and Password).
<b>Password</b>	Set Password to access the service (only if access is protected by UserID and Password).
<b>PIN</b>	PIN to use the SIM card.

### Managing of profiles of servers of permanent stations (NTRIP)

A server NTRIP is a permanent stations service to connect through internet receiving differential corrections in real time. Setting a server you need to enter following parameters:

Server	
<b>Name</b>	Description (name) of provider
<b>Mode</b>	NTRIP
<b>IP address</b>	IP address where the service answers
<b>Port</b>	Number of the port used
<b>UserID</b>	Identification of the registered user to service
<b>Password</b>	Password assigned to registered user by the service

IP address, port, UserID and Password they are all data provided when you register yourself to the service.

### Managing profiles of direct call

A direct call profile allows to set the telephone number of the SIM card used by receiver Base to allow rover receiving corrections from the base using the modem GPRS instead of radio:

Server	
<b>Name</b>	Description (name) of profile
<b>Mode</b>	CSD (Direct call)
<b>Base number</b>	Telephone number of the SIM used by the base
<b>Protocol</b>	Transmission protocol; only for Zenith10/20/35
<b>Speed</b>	Transmission speed; only for Zenith10/20/35
<b>Connection</b>	Type of connection; only for Zenith10/20/35

Both base both rover must use the same profile **Direct call**.

### Management of Point-To-Point (PPP) profiles

A Point-To-Point profile allows to set the IP address and the port number on which execute the connection to receive corrections.

Server	
<b>Name</b>	Descriptive name of the profile
<b>Mode</b>	PPP (Point to Point)
<b>IP</b>	IP address
<b>Port</b>	Port number used
<b>UserID</b>	Identification of the user registered to the service
<b>Password</b>	Password assigned to the user registered to the service

### Management of Dynamic DNS (DDNS) profiles

With Dynamic DNS it's possible to set a base and rover system in which the base is able to support up to 10 rover at the same time using GPRS network.

Server	
<b>Name</b>	Descriptive name of the profile
<b>Mode</b>	DDNS (Dynamic DNS)
<b>Service provider</b>	Insert address of the service provider; some service providers to use are: <ul style="list-style-type: none"> <li>• DynDNS.com (default)</li> <li>• easydns.com</li> <li>• no-ip.com</li> <li>• two-dns.com</li> </ul> It's necessary to subscribe service to one of these providers. HostName, UserID and Password will be provided by the service manager.

<b>Host name</b>	Host name assigned by the service provider
<b>Port</b>	Port number used
<b>UserID</b>	Identification of the user registered to the service
<b>Password</b>	Password assigned to the user registered to the service

## Creation of a profile using the GPS of the device

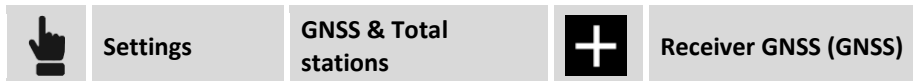

Step	Description
1	Assign a name to profile
2	<b>Mode: GNSS Rover</b>
3	<b>Brand: NMEA</b>
4	<b>Model: GPS Hardware</b>
5	
6	<b>Antenna elevation:</b> set the default antenna elevation
7	

## Creation of a new Total station profile

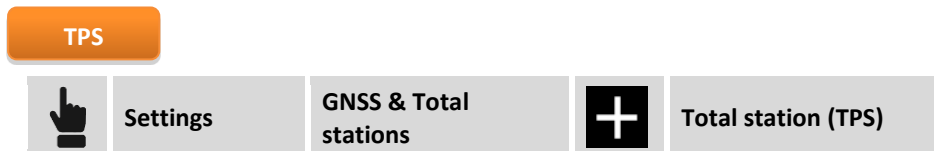



Parameters and options requested are different according to model of total station and mode of operation. Parameters are organized in pages.

### Profile page

Field	Description
<b>Profile name</b>	Name to assign to profile
<b>Mode</b>	Total station
<b>Brand</b>	Brand of the station
<b>Model</b>	Model of the station

## Device page

Field	Description
Device	Bluetooth Name of the instrument to connect. If the instrument does not appear in the list hit  and then  to start research.
Angles update frequency	Frequency with which the value of the angles is updated. For some it's possible to set maximum frequency ( <b>2 times per second</b> ) instead for other older models you have to set <b>None</b> .

## Passive recordings

In case of use of GeoMax Zoom20/30/35 total stations it's possible to press REC key on keyboard of the station in order to send the measure data directly to X-PAD which will record directly the measured point.

---

## Editing a profile



Select profile to edit and then select **Modify**.

---

## Deleting a profile



Select profile to delete and then select **Delete**.

---

## Make current a profile



Select profile to make current and then select **Current**.

---

## Reconfigure instruments



Select profile corresponding to instrument to reconfigure and then select **Configure**. Instrument will be reprogrammed basing on settings defined in the profile.

---

## Creation of a new profile Laser Disto

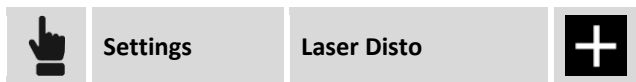



It's possible to create one or more profiles related to instruments as Laser Disto; the program can use these profiles in measuring of points not accessible by the GPS receiver; the point to measure is calculated by intersection of two distances from two known GPS positions. The measure of distance can be performed with Disto and automatically transferred to software.

### Profile page

Field	Description
Profile name	Name to assign to profile
Brand	Brand of the laser Disto
Model	Model of the laser Disto

### Device page

Field	Description
Device	Bluetooth Name of the instrument to connect. If the instrument does not appear in the list hit  and then  to start research.

### Parameters page

Field	Description
Laser elevation	Elevation from ground of the laser Disto. The elevation from ground is used for calculation of slopes between GPS position and point to measure.

---

## Creating a new Echosounder profile

BATHYMETRY

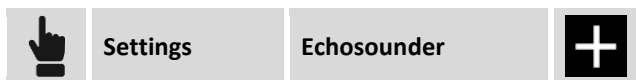



It's possible to create one or more profiles related to instruments of echosounder type; echosounder profile is used in bathymetric survey command available with bathymetry module.

### Profile page

Field	Description
Profile name	Name to assign to profile
Brand	Echosounder brand
Model	Echosounder model

## Device page

Field	Description
Device	Bluetooth name of the device to connect. If device is not in the list press  and then  to start research.

---

## Creating a new profile Cable detector

### LOCATORS





It's possible to create one or more profiles related to instruments of Cable detector type to allow acquiring position with GPS and depth with Cable detector.

## Profile page

Field	Description
Profile name	Name to assign to profile
Brand	Cable detector brand
Model	Cable detector model

## Device page



Field	Description
Device	Bluetooth name of the device to connect. If device is not in the list press  and then  to start research.

## GPS – GPS status

### GPS

When is active a profile of instrument **Rover GPS** or **Base GPS**, it's possible in every moment to access to a window showing general status of GPS receiver and allowing to modify different parameters of operation. The window visualizes all current parameters of receiver as position, quality of signal, number and position of satellites, information on base and position on Google map.







It is possible to access to window GPS status in following manner:

	Toolbar on main menu, when is active a profile <b>Rover GPS</b>
	Toolbar on main menu, when is active a profile <b>Base GPS</b>
	Click on panel in survey and stakeout windows

Information are organized in pages.

## Quality

The page reports all the information relative to quality with which the receiver is working.

GPS status - Quality	
Position	 <b>RTK Fixed (Safe mode):</b> receiver is receiving corrections from a source and it has fixed the ambiguity in Safe mode (maximum precision and security); only for Zenith35 receiver.
	 <b>RTK Fixed:</b> receiver is receiving corrections from a source and it has fixed the ambiguity (maximum precision)
	 <b>Quick Fix:</b> receiver has fixed the ambiguity but it hasn't still reached the maximum precision level; only for receiver Zenith25.
	 <b>RTK Mobile:</b> receiver is receiving corrections from a source but it has not yet fixed ambiguity
	 <b>DGPS:</b> receiver is receiving differential corrections in DGPS mode.
	 <b>Autonomous:</b> receiver is acquiring position in autonomous way without receiving corrections from any source (minimum precision)
2D precision	Precision of current position regarding coordinates



<b>Elevation precision</b>	Precision of current position regarding elevation
<b>Extra safe mode</b>	Enables Extra-safe mode (only for Zenith35 receiver) capable to guarantee maximum precision in calculation of coordinates.
<b>Satellites</b>	Number of satellites of the different constellations
<b>HDOP</b>	Horizontal DOP
<b>VDOP</b>	Vertical DOP
<b>PDOP</b>	General DOP related to satellites position
<b>Age corrections</b>	Delay in receiving corrections (seconds); a high value indicates missing of corrections received
<b>GSM signal</b>	Level of GSM signal
<b>NTRIP Server</b>	Name of the used NTRIP server
<b>Mountpoint</b>	Name of the mountpoint to which you have been accessed

---

## Position

GPS status – Position	
<b>Geographic Coordinates</b>	Current Latitude, Longitude and elevation
<b>Antenna elevation</b>	Elevation of the antenna
<b>Plane Coordinates</b>	Corresponding plane coordinates; values are available only if a coordinates system has been set

---



## Skyplot

SkyPlot reporting position and elevation of tracked satellites. Clicking on a satellite it appears a window showing all its information.

---

## Satellites

The table reports the list of all tracked satellites with all related information.

GPS status – SV	
	Indicates satellites contributing to position calculation and ignored satellites
	Number of the satellite and constellation
<b>Position</b>	Indicates position of satellite with cardinal points
<b>Elevation</b>	Indicates the elevation of the satellite in the sky
<b>Signal/Noise</b>	Signal/noise ratio

---

## Base

The table reports information related to the reference base.

Status GPS – Base	
Base	Name of the base
Place	Place where is the base (only for connection to Leica ITALPOS network)
Latitude/Longitude/ Elevation	Coordinates of the base
Distance	Distance between base and current position

---

## Map

The page visualizes current position on Google Map and other provider.

---

## Utility commands

From window GPS Status it's possible to edit parameters of operation of the receiver.

### Tools



GNSS Status	
Setup receiver	Allows access to profile settings
 Start GNSS MOCK Location	Allows you to set as the position of the controller the position of antenna. All applications requiring the GNSS position of the device will receive the position of the GNSS GeoMax receiver instead of the position of the receiver inside the device. To use this feature, you need to enable Developer Mode in Android settings.

### Reset RTK correction



Performs a reset of RTK corrections received previously forcing the receiver to re-initialize the calculation of position.

### Activate/Deactivate use of constellations



Allows to activate and deactivate the use by the receiver of constellations GLONASS, BEIDOU, SBAS.

### Change cut-off angle



Allows to modify the minimum elevation to which satellites must be to be used in calculation of the position.

### Connect/Disconnect GPRS



Allows to stop or restart GPRS connection.

### Change mountpoint



Command allows to modify mountpoint from which to receive corrections RTK through GPRS.

**Pay attention.** In choosing mountpoint compatibility with RTCM format set during receiver configuration must be maintained. If in receiver configuration it has been set RTCM2 as data format of corrections it's not correct to choose a mountpoint transmitting correction in another format.

### Reconfigure receiver

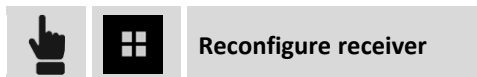

Command starts procedure of complete reconfiguration of the receiver according to current GPS profile.

### Editing GPS profile



Command opens the window allowing to review and edit settings of current GPS profile.

### File Manager



Opens a window visualizing all files with raw data present in the receiver memory. Files can be deleted or selected to be copied in the controller memory.

### Stop raw data log



Stops recording of raw data by receiver.

### Change radio channel



Allows to modify the number of the channel used by the receiver radio.

### Start output NMEA



Allows to set receiver to send on serial port, USB port or Bluetooth port the NMEA strings to be used by other devices and by other external software as echosounders, georadar etc.

It's possible to set the exit port, the NMEA strings to send and the exit frequency. Receiver is configured as requested and X-PAD stops connection with receiver leaving a free communication to software which will have to process the NMEA strings.

---

## GPS status panel

In all windows where you can perform GPS survey and stakeout operations it's present a panel similar to following:

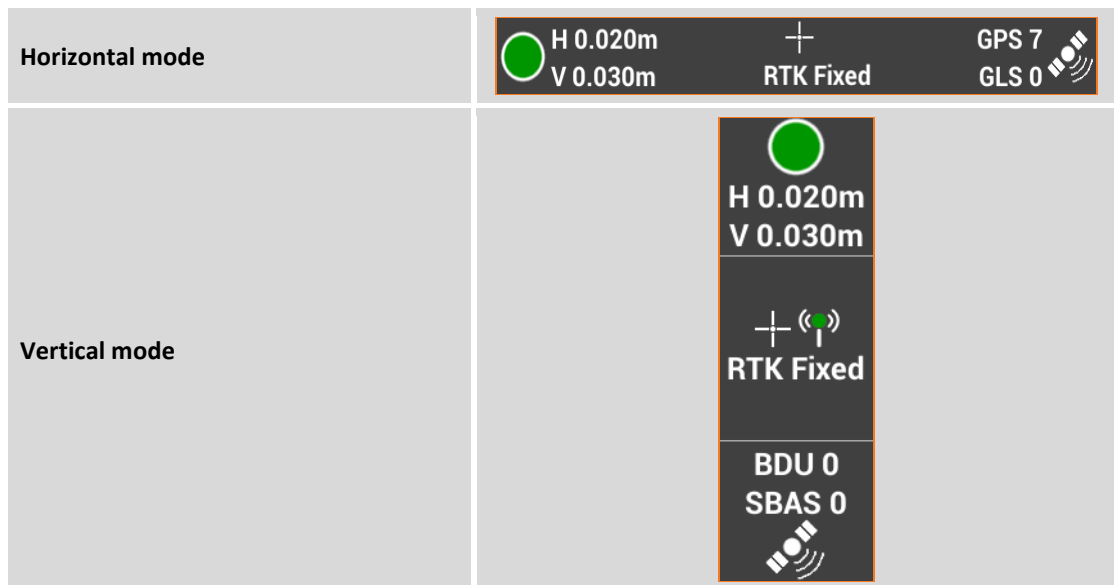





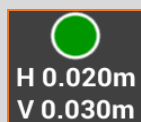





Clicking on panel you access to window **GPS status**.

### GPS status panel



Current precision for coordinates (H) and for elevation (V).

The traffic light,  or , indicates if the precision level set in the survey parameters, has been reached; the epochs are acquired only when the level of precision has been reached

		<b>RTK Fixed (Safe mode):</b> receiver is receiving corrections from a source and it has fixed the ambiguity in Safe mode (maximum precision and security); only for Zenith35 receiver.
		<b>RTK Fixed:</b> receiver is receiving corrections from a source and it has fixed the ambiguity (maximum precision)
		<b>Quick Fix:</b> receiver has fixed the ambiguity but it hasn't still reached the maximum precision level; only for receiver Zenith25.
		<b>RTK Mobile:</b> receiver is receiving corrections from a source but it has not yet fixed ambiguity
		<b>DGPS:</b> receiver is receiving differential corrections in DGPS mode.
	The antenna,  or  , indicates if the receiver is receiving corrections.	
	Number of satellites, for constellations GPS, GLONASS, BEIDOU, SBAS, actually tracked.	

---

## GPS - Starting a base

### GPS

Starting a GPS base is a main operation and it's the first thing to do when you work with a couple of receivers; first receiver (base) will remain in a fixed position on the ground and send corrections via radio to the second one (rover) which is free to move on the ground, according to radio range, and acquire or stakeout positions.

**Note.** Receivers can function in Base-Rover mode both through the use of the radio both through the use of modem GPRS. In this last case it's necessary having two SIM cards (one for the base and one for the rover) and setting a server in CSD mode (direct call) in the GPS profile of the base and of the Rover; in CSD profile must be defined the number of the SIM present on the base.

**Note.** Commands allowing to start a base are available only when it has been set a GPS instrument profile in BASE mode.

If current profile is related to a GPS receiver defined as a BASE the software presents only two menu: **Job** menu allowing to manage current job data and **Start base** menu to make operative the BASE receiver in the desired modes

---



### Starting a base on a known position

Use this mode when the base is positioned on a known position of which you know geographic coordinates; if you know only the plane coordinates it's necessary to define the coordinate system that allows to calculate the geographic coordinates starting from plane coordinates.



Field	Description
Base ID	Assign the name to base; the name of the base is visualized on the rover and the rover can be set so that it can accept only corrections coming from the base with a certain ID.
Code	Code to assign to point that will be created in correspondence of position of the base.
Antenna elevation	Measures the antenna elevation from ARP (Antenna Reference Point) to the ground
Record data for post-processing	Activate the option to start simultaneous recording of raw data by the base; raw data recorded can be useful for a next post-processing elaboration.
Log frequency	Frequency with which recording raw data
File for PP	Name of file where to save raw data
File type	Set the kind of file to store

Field	Description
Reference point	To assign coordinates to base it's possible:

	<ul style="list-style-type: none"> <li>- to select a point of the archive (from graphic, table or adding a point in the point table); coordinates of the point are visualized in corresponding fields</li> <li>- to insert manually the geographic coordinates of position of the base</li> <li>- to insert manually the plane coordinates of position</li> </ul> <p>In every case, if the geographic coordinates are not available but you have only the plane coordinates it's necessary to define first a coordinate system so that can be calculated the corresponding geographic coordinates.</p>
	Enables the input of plane coordinates and elevation of the point.
	Enables the input of geographical coordinates and ellipsoidal height of the point

Field	Description
<b>Create local system on base</b>	This option allows to create, simultaneously to programming the base, a local coordinate system on 1 point having just the base as reference point. If the option is activated it's possible to specify the local coordinates corresponding to position of the base.
 <b>Start base</b>	Hit the button to perform the complete programming of the base and the start of operating. In this phase, the receiver acquires the current position and checks that there isn't a difference over 5 seconds between current position and position inserted.

When programming and starting the base is over it is proposed the list of available Rover GPS profiles; select the rover profile with which you want to proceed with the job. The selected profile becomes automatically the current instrument profile.

## Starting a base on current position

Use this mode when the base is positioned in a place of which you don't know coordinates; the base is started with the position approximated by the receiver.



The meaning of the fields and the steps to execute are exactly the same of the previous paragraph; when you have to specify the coordinates of the base hit button **Measure here**; you can choose one of the following options:

Field	Description
<b>Get approximate position</b>	Store the approximate position of the receiver.
<b>Get RTK position from NTRIP</b>	If there is a GPRS RTK profile for the same receiver used as the base it is possible to obtain an accurate position of the base.

The current position of receiver is visualized in corresponding fields.

---

## Starting a base with previous settings

Command allowing to repeat programming of the base using previous programming data. Guided procedure shows coordinate that will be assigned to the base and then proceeds to configuration.



---

## Start a base with Automatic (RTK position) settings

Use this mode when the base is in a position of unknown coordinates.

To use this mode, you need to configure an RTK NTRIP profile for the same receiver. The software configures the receiver in GPS RTK – NTRIP mode to determine the base position. After acquiring the precise position the receiver is started as a base with the mode “known position”.



The meaning of the fields and the steps to execute are exactly the same of the previous paragraph “Starting a base on a known position”; when you have to input the base coordinates press the **Measure here** button; the current position of the receiver is displayed in the corresponding fields.

By hitting  button it is possible use the tool **Search closest ref point**, this allow to choose the coordinates of the reference point closest to the receiver position as the known base position. In this way, if there are more than one base reference point on a work site, it is not necessary to remember the name of the reference point, because the program automatically shows the correct one based on the antenna position.



## Survey of points – GPS and TPS common functions









GPS











TPS

This chapter explains some commands and functions that are present both in survey of points with GPS both in survey with total station.

### TPS and GPS display mode

You can set the display mode of the graphical window by hitting on the button that shows the active display mode.

Visualization mode			
		<b>2D</b>	Enables 2D drawing display.
		<b>3D</b>	Enables 3D drawing display.
		<b>Map</b>	Enables 2D display of a reference map.
		<b>Working area</b>	The icon notifies that the drawing extension is too large to appropriate display all elements and allows you to define the working area. For information about the setting of working area refer to chapter “CAD” and paragraph “Control of the visualization”.

	GPS	TPS	Automatic update of view	
			<b>Direction</b>	Enables the automatic update of the view oriented according to the direction of the instrument.
			<b>North</b>	Enables the automatic update of the view oriented according to the North
			<b>Disable</b>	Disables the automatic update of the view
			<b>Controller compass calibration</b>	Notifies that the compass of the controller is not calibrate and it is required to perform the calibration procedure.

### Using the maps

X-PAD allows you to use different types of maps as a reference base for surveying and staking out activities so that the software can show all the data superimposed on a map. You can choose from maps of Google, Bing, OpenStreetMap and many more. It is possible superimpose WMS (Web Map Service) maps on the main maps, the Web Map Services are made available by government agencies or other offices and representing additional elements typical of the area and specifically interesting for the important activity that is taking place.



### Select the map to view



In the tab **ON-LINE MAP** it is showed up a list of predefined maps; You can choose the desired map or choose **NONE**, if you don't want to see any main map but only WMS maps.

In the tab ON-LINE WMS it is showed up a list of defined WMS maps, it is possible to show more than one WMS map.

### WMS maps (Web Map Server)

In addition to the predefined maps you can create connections to WMS maps.



Field	Description
<b>Name</b>	Name to assign to WMS map
<b>Url</b>	Address of WMS map
<b>User</b>	Username for accessing to the WMS service, if required by the WMS
<b>Password</b>	Password for accessing to the WMS service, if required by the WMS
<b>Layer</b>	Select layer to visualize among the ones available in the server
<b>Projection</b>	Shows the projection system of WMS service

### Creating maps to use in off-line mode

Before proceeding to save of an off-line map, make visible the reference map and eventually the WMS maps.

Then set view in order to include the zone you are interested in, to save for off-line mode use.

Field	Description
<b>Map name</b>	Name to assign to off-line map
<b>Zoom Min</b>	Minimum level zoom
<b>Zoom Max</b>	Maximum level zoom
<b>Tiles count</b>	Basing on the limits of the zone and of the zoom it's calculated the number of tiles to be downloaded

When finished with download of all tiles the off-line map is available and can be used.

**Warning.** Number of tiles can be great and request much time to complete download and take much space on the disk. It's appropriate so not to exceed in the extension of the zone to save and to save only the necessary levels of zoom.

### Using off-line mode maps

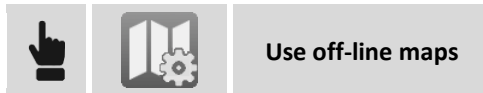

Select among the off-line maps available the ones to visualize.

### Saving the current view as image



### Augmented reality

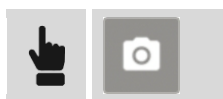

It's activated the photo camera of the device and, basing on GPS position and on parameters of inclination and direction of device, it's visualized the drawing in overlap to pictures coming from camera.

---

### Controller compass calibration



The software notifies that the controller compass is not calibrated. It is required perform the calibration procedure by the movement showed in the following image.



The compass is used in the drawing display to indicate the position of the NORTH.

---

### Electronic bubble

The software is able to use the sensors present inside the controller to visualize an electronic bubble directly on the display; this way the operator can maintain the attention on the display instead of looking always the bubble on the pole. Moreover the software is able to avoid the acquisition of epochs when the pole is out of the bubble.

The assumption for the correct functioning of the system is to have a solid strut of the controller on the pole so that controller and pole can move together and not independently of one another.

### Activation of the electronic bubble



Select item **E-Bubble (controller)** in correspondence of the item **Sensors mode**. To disable quickly the use of the electronic bubble, click on the bubble and select item **No sensors**.

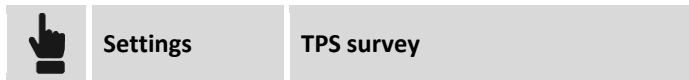

### Calibration of the electronic bubble

When it's selected a survey and stakeout command it's visualized the window allowing to perform calibration of the electronic bubble. The calibration is a necessary operation allowing to determinate the position of the controller referring to the pole.



To perform the calibration it's necessary to use the physical bubble to maintain perfectly in bubble the pole for some seconds. At the end of the calibration procedure the position of the electronic bubble that is visualized in the survey and stakeout windows will correspond to the position of the physical bubble. If the calibration procedure has been previously performed, and the controller doesn't change position referring to the pole, it's possible to skip the procedure and pass to next window.

---

### Survey codes assignment

It's possible to assign survey codes to the point in different ways.

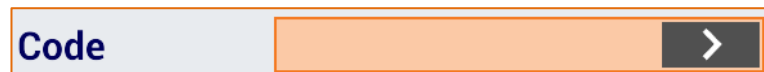

#### Manual insertion of code

Type code directly in the field **Code**.

#### Selection from table of the code

Hit on button  to access to window allowing to select codes; in the page **List** you find the table containing the survey codes: select the desired code from the list.

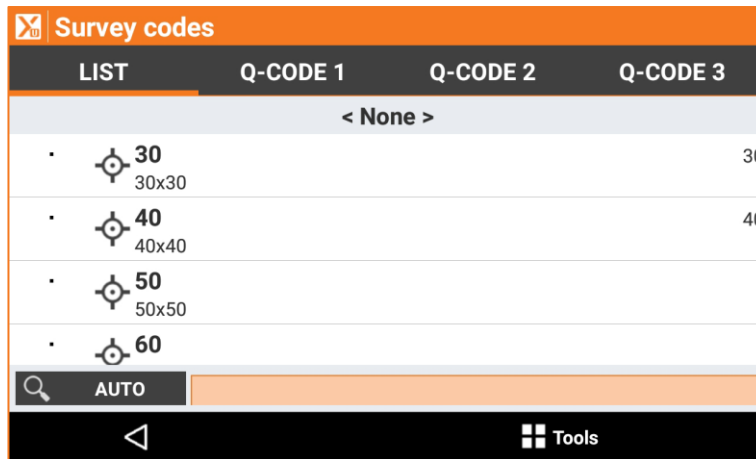

The input field located in the lower part allows to perform a research among codes; the button on the left allows to specify as research has to be executed:

State	Description
AUTO	Research is performed both on code both on description
COD	Research is performed only on code
DESC	Research is performed only on description

		Sort Alphabetic
		Sort Last used

Codes can be listed basing on alphabetic order or basing on use; in this second case they are reported in the first places of the table the most used codes.

### Edit a code during surveying

Hit on button  to access to window allowing to select codes; in the page **List** you find the table containing the survey codes:

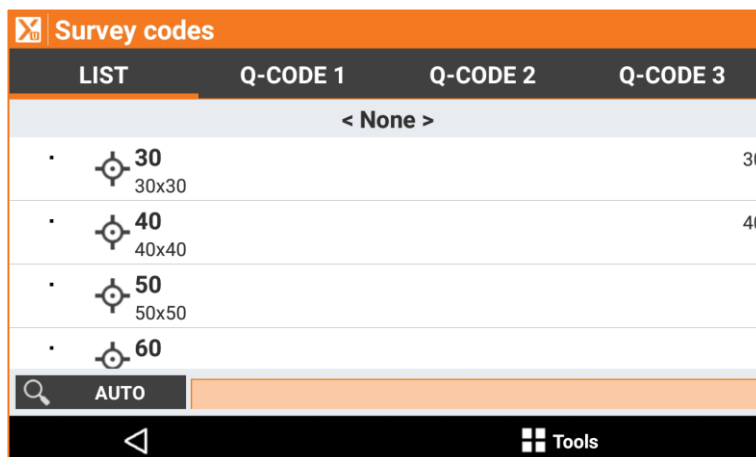



Select the code and hit **Edit**. Perform the modifications and hit .

## Quick codes

Quick Codes are a selection of the codes in the list that can be grouped according to the user's needs into one or more pages. This allows for faster access to the desired survey code.

### Selection of Quick codes

Hit on button  to access to window allowing to select codes; in the page **Q-Code1/Q-Code2/Q-Code3** are visualized some buttons corresponding to some codes. Choose the code hitting the corresponding button.

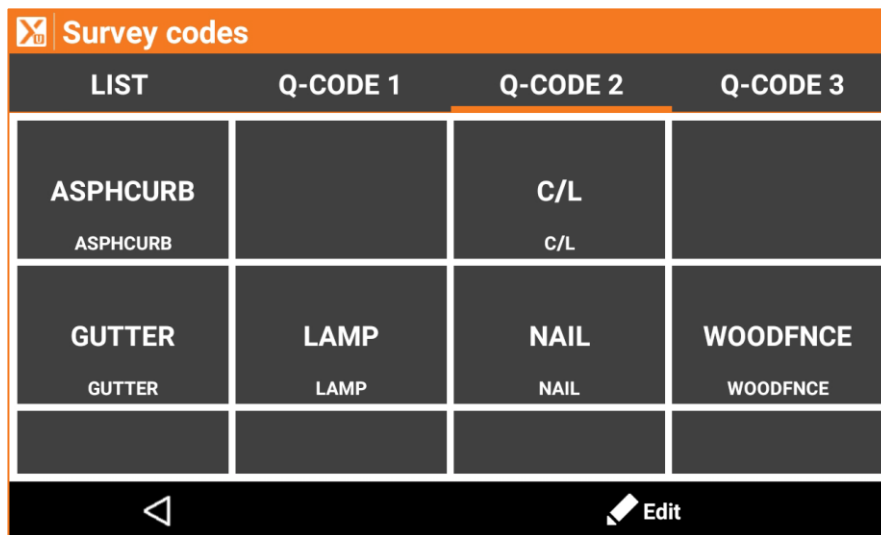

In the survey settings it's possible to activate an option that starts automatically the measure after selection of the quick code.



### Customization of Quick codes



It is possible to customize the codes in the quick codes pages as follows.



Step	Description
1	 to access to window allowing to select codes
2	Select one of the three pages with quick codes
3	 select <b>Quick-Codes customization</b>
4	Hit one of the unset buttons and select the code from the list.

5	Repeat the operation for all buttons you want to customize
6	 end the quick code customization mode

### Add Quick-Codes page



It is possible to add Quick-Codes pages as follows.

Step	Description
1	 to access to window allowing to select codes
2	 select <b>Add Quick-Codes page</b>
3	Hit one of the unset buttons and select the code from the list.
4	Insert the name of the page
5	OK

### Rename current page

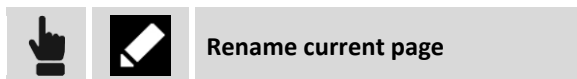

The command allows to rename the current Quick-Codes page.

### Delete current page

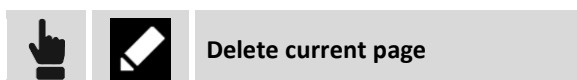

The command allows to delete the current Quick-Codes page.

---

## GIS features





If a GIS feature has been associated to a code of the point, it appears a window visualizing the attributes of the GIS feature that have to be filled in by the operator.

The window can be organized in pages, one for every GIS feature, because to the point it's possible to associate more than one code (composed codes).

For every page are visualized the attributes expected by the feature as input fields to fill in.



 <b>From point</b>	Loads values of the attributes saved in one of the points of the job; select the point from which to load values of the attributes.
 <b>From previous</b>	Loads values of the attributes saved in previous point.

## Smart Drawing – Drawing during survey

SmartDrawing is a function allowing to generate drawing during measuring points; they are available two functioning modes:

Mode	Description
<b>Single lines</b>	Allows creation of single lines between points and drawing of circle, rectangles and squared objects
<b>Multiple lines</b>	Allows creation contemporarily of more lines, even with the same code, for complex survey situations

To access to SmartDrawing click on lower button of the left side panel in points survey window.

### Single lines

The toolbar SmartDrawing appears hitting corresponding button in the survey window.

Tool	Description
<b>Point</b>	Simple saving of single points
<b>Line</b>	Creates lines between points
<b>Arc</b>	Creates arcs between points
<b>Circle 3P</b>	Creation of a circle through measuring of 3 points
<b>Circle C+R</b>	Creation of a circle through measuring of center and of one point on circumference
<b>Square</b>	Creation of a square through measuring of two opposite angles
<b>Square Center</b>	Creation of a square through measuring of the central point and of one middle point of a side
<b>Rectangle Base</b>	Creation of a rectangle through measuring of two points of the base and any point on opposite side from the base
<b>Rectangle Center</b>	Creation of a rectangle through measuring of the center, of one middle point of a side, and any point on opposite side
<b>Break</b>	Break the drawing of the current line
<b>Close</b>	Close the current line to the first point
<b>Master point</b>	Allows to store a point of Master point type.
<b>Selection point</b>	Allows to select the requested point on video among the ones still present
<b>Use last point</b>	Allows to use, as requested point, the last saved point



When you select a tool, in SmartDrawing button is visualized the request related to the point to measure. Example:

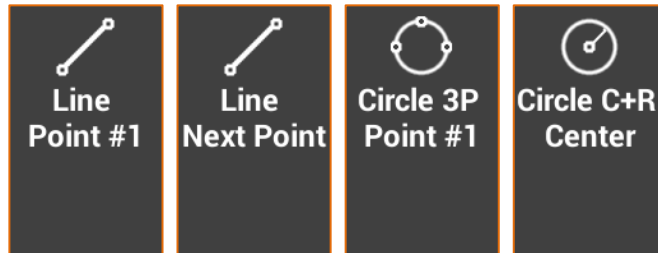

When it's selected a survey code, it's automatically activated the tool corresponding to the type of drawing set in the code.

### Multiple lines

**Multiple lines** mode allows to generate lines between points basing on the code of the point and the number of the line. Lines are distinguished in **ACTIVE** lines and **NON ACTIVE** lines: ACTIVE lines are the lines actually used in survey and their drawing is not yet completed; NON ACTIVE lines instead are the lines still measured and drawn and that are completed.







A line born as ACTIVE line, is integrated with points that form its development, and at the end becomes a NON ACTIVE line; a NON ACTIVE line can again become an ACTIVE line in case you must complete its drawing with new points.











### Example of job with multiple lines

In a road survey, for example, there are two sides (left and right) and the axis of the road; in this case it's possible to create two lines with **RS** (road side) and a line with code **CL** (center line). The two lines **RS**, having the same code are distinguished by the line number: first line will have number 1 and the second number 2.

Moreover the codes **RS** and **CL** must have as drawing type the attribute **Line**.

Having to do the road survey, you will operate as follows:

Step	Description
<b>Button SmartDrawing</b>	Open the control window SmartDrawing
	Open the lines management window
	Add a new line
	Select code <b>RS</b> corresponding to the road side; the code must be of Line type. The line <b>RS number 1</b> will be created.
	Add a new line
	Select code <b>CL</b> corresponding to the road axis; the code must be of Line type. The line <b>CL number 1</b> will be created.
	Add a new line
	Select code <b>RS</b> corresponding to the road side; the code must be of Line type. The line <b>RS number 2</b> will be created.

	Select by the list the line from which to start: <b>RS 1</b>
	Go back to survey window; the current code is now <b>RS</b> and is reported the line number <b>1</b> .
	Measure the first point of the road side
<b>Button SmartDrawing</b>	Open the control window SmartDrawing: in this case you enter directly in the lines management window.
	Select by the list the line of the road axis: <b>CL 1</b>
	Go back to survey window; the current code is now <b>CL</b> and is reported the line number <b>1</b> .
	Measure the first point of the road axis
<b>Button SmartDrawing</b>	Open the control window SmartDrawing: in this case you enter directly in the lines management window.
	Select by the list the second line of the road side: <b>RS 2</b>
	Go back to survey window; the current code is now <b>RS</b> and is reported the line number <b>2</b> .
	Measure the first point of the second road side
	Measure the second point of the second road side; the drawing of the line of the second road side appears in the graphic window
	Go on this way selecting by the line management window the line you must measure

### Adding a new line



Specify the code to assign to the line; the code must be of **Line** type. The line number will be the first free number available considering the lines still present with the same code. Another way to create a new line is to insert the code directly in the points survey window; if the inserted code is of line type, a line with that code will be automatically created.

### Select the line to use



Select from the list the line that will be used for the next measure. Coming back to the survey window the code of the line is set as current code. Another way to select a line to use for the next measure is to select it directly from the graphic window.

### Duplicating a line



Create a new line, empty, with the same code of the selected line; The line number will be the first free number available considering the lines still present with the same code.

### Ending a line (disabling)



When the drawing of a line is completed it's not necessary to maintain it in the list of the ACTIVE lines; it's possible to end it and bring it in the list of the NON ACTIVE lines.

### Deleting a line



To delete a line definitively it's necessary to select it and choose item **Delete** from menu that appears.

### Inverting a line



When a line has been selected, the new points measured are added always at the end of the lines. In some cases can be necessary to add the points at the beginning of the line; in this case it's necessary to invert direction of the line before adding new points. Select the line from the list and choose item **Invert**.

### Closing a line



If the drawing of the line regards a closed element as a particle, the contour of a building etc. it's possible to close the line: the first vertex will be united by a line with the last vertex. The line is moved automatic in the list of the NON ACTIVE lines. Select the line from the list and choose item **Close**.

### Multiple codes

In some cases when you measure a point you need that this is the limit of more lines actually opened.



Select the lines in the list to which you want to add the point that will be measured; to all selected lines will be added as new vertex the next measured point.

### Automatic codification

The automatic codification system allows to make very quick the surveying phases where the elements to measure occur regularly; it's the case of the survey of a road where you have to survey the side elements and the axis.

In these cases it's possible to define the list the list of the lines to measure in the correct order and activating the **Zig-Zag** mode or **Same direction**; when one of these modes is active it's no more necessary to select the line to draw but the system purposes automatic the line basing on the defined order.

There are two types of order that can be executed:

Order	Description
<b>Zig-Zag</b>	Survey must be executed from left to right and then from right to left and then again from left to right.
<b>Same direction</b>	Survey must be executed always from left to right or always from right to left.



After having enabled the automatic code mode it's proposed the code of the first line in the list; just after the measure of the first point it's proposed the code of the second line in the list and so on. It's possible to stop definitively the sequence, skip a code and pass to the next or to pause the system because before proceeding it's necessary to measure other single points not included in the sequence.

---

### Average coordinates

A point can be measured more than one time and in different times. During the operations of measuring, when it's defined the name of a point still measured, it's requested to specify as you want to proceed:

Existing point	
<b>Overwrite point</b>	The previous point is deleted and it's created a new point with the same name.
<b>Additional measure</b>	It's saved a new measure for the point. If in the survey settings the option <b>Average coordinates</b> has been set, the coordinates of the point are re-calculated considering all measures performed.
<b>Next point</b>	It's proposed the name of next point not yet saved.

---

### Tools & utilities

In survey window they are available different tools and functions that can be very useful during measuring operations.

### Edit last point



Opens the dialog box allowing to edit the last point measured.

### Delete last point



Opens the dialog box allowing to delete the last point measured.

### Share last point

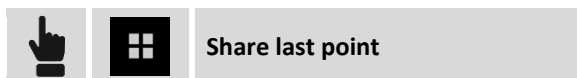

Opens the dialog box allowing to share the last point measured. Choose the sharing method and complete the procedure; for the selected point they will be sent the information related to coordinates (geographic and plane), the code, the description and the eventual photo/sketch associated.

### Adding a note

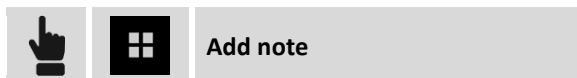

During survey operation it's possible to add in the fieldbook some measures, descriptive notes and sketches that can be a valid reference at the moment of elaborating the measured data in the office.

### Points & measures



During the survey operations it can be useful to access to the table of the points or to the fieldbook of measures to check data and eventually correct some wrong values of antenna elevation, code and description.

For further information on window of the fieldbook of measures please refer to chapter **Managing of points and measures**.

---

## X-Pole: one pole, two systems

### X-POLE

**X-Pole** solution allow you to work simultaneously with TPS and GNSS using the best features of each system as required and with maximum flexibility.

The TPS can be oriented directly thanks to the GNSS position that can be acquired simultaneously with the measurement of the prism. It is not necessary prior to measuring points with GNSS and then measure the same again with the TPS; the operation can be performed at the same time with greater speed and accuracy.

A single click is what you need to change the measurement mode and switch from GNSS to TPS mode and vice versa. From the operator's point of view, the change of system is hardly noticeable, since it only changes its panel to the current instrumentation.

The GNSS system positioned above the prism allows you a direct rotation on the prism direction speeding lock operations of the prism after loss. With GNSS initialized the TPS is rotated in the exact position of the prism and the lock is immediate without any search; with a GNSS position not initialized the TPS is rotated in the approximate position and started the search for the prism in the surrounding area. In both cases the locking speed of the prism is greater than the traditional search.

---

### Using X-Pole in the station setup

X-Pole system is particularly useful in station setup because it's possible to use the position provided by the GPS mounted on the pole. This way the station will be oriented and located in the same reference system used by the GPS receiver.

#### Free station

Station setup with free station requests to measure points with known coordinates; with X-Pole the points with known coordinates are provided by GPS.

While measuring points for calculation of the free station it's requested to specify the point of known coordinates: open menu and choose item **Measure** to proceed with measuring with GPS.

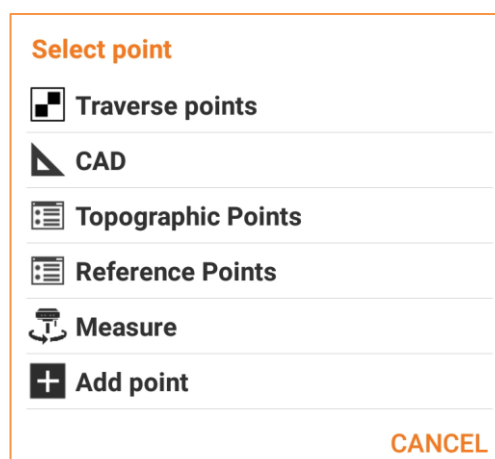

The point for the free station can be this way measured with GPS receiver; the point is measured and added in the list of points and becomes the requested known point. Procedure goes on with measure of the same point with total station completing this way the measuring procedure of the known point for calculation of the free station.

## Backsight point

Station setup with a backsight point requests a point with known coordinates; with X-Pole the point position can be provided by the GPS.

Station setup procedure requests to specify the point of known coordinates: open menu and choose item **Measure** to proceed measuring with GPS.

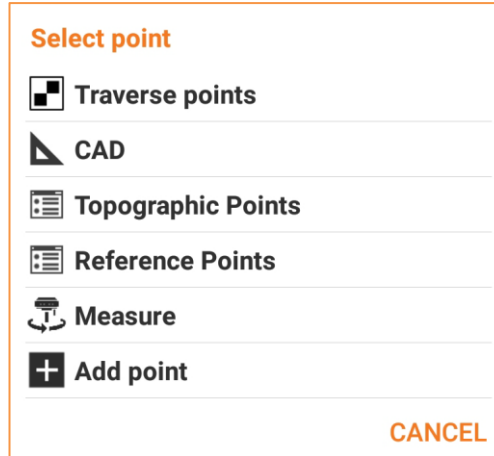

The backsight point can be then measured with GPS receiver; the point is measured and added in the list of points and becomes the requested known point. Procedure goes on with measure of the same point with total station completing this way the measuring procedure of the known point for calculation of the station orientation.

---

## Using X-Pole in site calibration

X-Pole system can be used to calculate the site calibration using positions measured with total station; this way you can use GPS in the same reference system established with total station.

Site calibration requests to measure a point with GPS and that of the same point they are provided the plane coordinates; coordinates can be the result of measuring made with total station.

When is requested to indicate the point of known coordinates it's possible to open menu and choose item **Measure** to proceed to measuring of the same with total station.

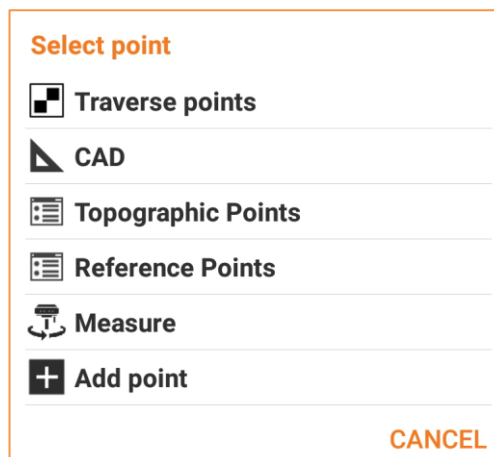



The point is measured with total station, added in the list of points and becomes the requested point to proceed with GPS site calibration.

---

## Using X-Pole during survey

X-Pole system is available in points survey windows. In the upper part of the window a button allows to pass to the other survey mode: in the GPS survey window it's possible to pass to total station survey and vice-versa.



Icon	Description
	From GPS survey mode you pass to total station survey mode. The target height is automatic adapted.
	From total station survey mode you pass to GPS survey mode. The pole height is automatic adapted.

---

## Pole height

X-Pole system requests installation of the GPS receiver over the prism; the height of the GPS receiver then will be no more the one of the pole but must keep in consideration the distance between the center of the prism and the reference point of the receiver.

When you start using X-Pole system the pole height of the receiver is automatic managed keeping in consideration the offset between center of the prism and receiver.

When you modify the pole height it appears a window similar to the following allowing to specify correctly the height avoiding errors.

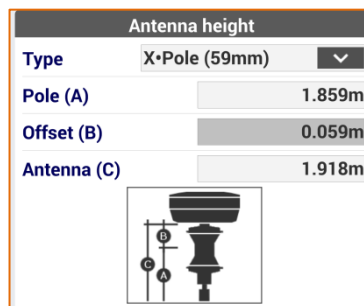

---

## Research of the prism from GPS position

When X-Pole system is functioning it's enabled the automatic prism research using the position provided by GPS receiver: when the prism is lost the software uses the position provide by GPS to turn the station in the direction where is the prism helping this way the automatic locking. It's possible to use also the manual mode and to call the station toward prism (knowing the GPS receiver position).





## GPS - Survey of points

### GPS

This chapter illustrates commands allowing measuring of points with GPS instruments; they are analyzed different operative modes.

**Note.** Commands of measuring of points are available when it's set a profile of GPS instruments in ROVER mode.





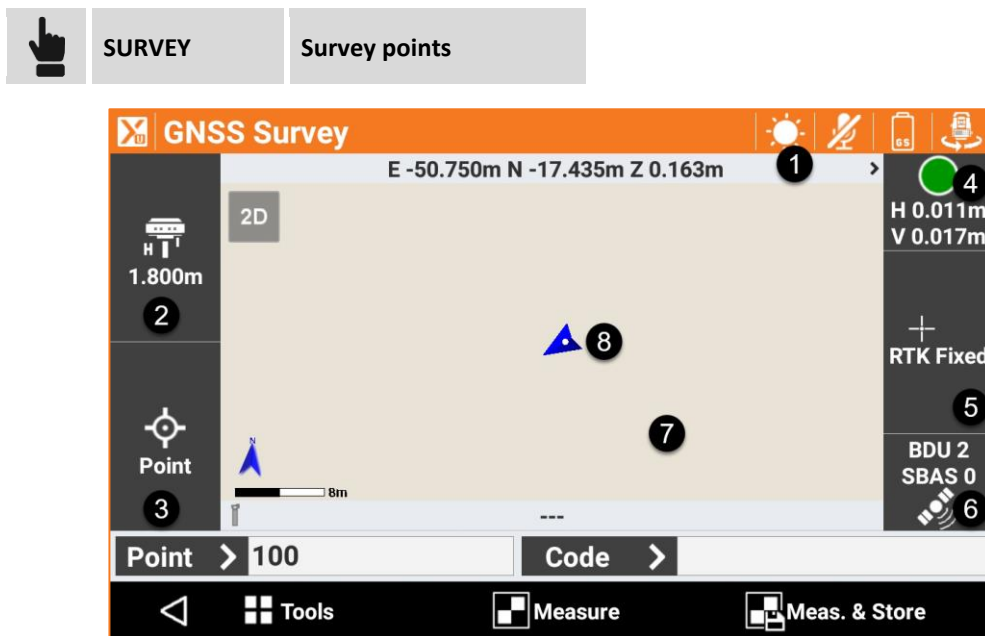



### Survey of points

The procedure allows to measure and record the position of points, even in conditions when the point to measure isn't measurable directly with receiver.



The window presents some panels on external sides reporting different information about receiver status and allowing to manage the different available functions.

Panel	Title	Description
1	Coordinate	The panel reports the geographic coordinates (latitude, longitude, elevation) of receiver; clicking on panel you pass to visualization of plane coordinates (East/North/Elevation). Clicking you return again to geographic coordinates.
2	Antenna elevation	Elevation of the antenna of the receiver. Clicking on panel it's possible to modify the elevation.
3	Smart Drawing – Drawing during survey	The panel reports the current status of the function Smart Drawing; clicking on panel it's possible to choose the tool of drawing or the operation to perform. See paragraph <b>Smart Drawing</b> .

4	Accuracy	The traffic light,  or  , indicates if the precision level set in the survey parameters, has been reached; the epochs are acquired only when the level of precision has been reached (horizontal and vertical precision, minimum number of satellites, maximum values of DOP, electronic bubble). Under the traffic light they are reported the current precision values for coordinates (H) and for elevations (V).
5	Receiver status	 <b>RTK Fixed (Safe mode):</b> receiver is receiving corrections from a source and it has fixed the ambiguity in Safe mode (maximum precision and security); only for Zenith35 receiver.
		 <b>RTK Fixed:</b> receiver is receiving corrections from a source and it has fixed the ambiguity (maximum precision)
		 <b>Quick Fix:</b> receiver has fixed the ambiguity but it hasn't still reached the maximum precision level; only for receiver Zenith25.
		 <b>RTK Mobile:</b> receiver is receiving corrections from a source but it has not yet fixed ambiguity
		 <b>DGPS:</b> receiver is receiving differential corrections in DGPS mode.
		 <b>Autonomous:</b> receiver is acquiring position in autonomous way without receiving corrections from any source (minimum precision)
6	Satellites	 Number of satellites, for the different constellations, currently tracked. <b>GPS:</b> constellation GPS <b>GLS:</b> constellation GLONASS <b>BDU:</b> constellation BeiDou/Compass <b>SBAS:</b> constellation SBAS
7	Graphic area	Graphic view with visualization of survey and drawing. Clicking two times in graphic part you access to main CAD window.
8	Current position	Indication of current position; if the symbol is blue it means that all parameters of operation satisfy the preset level of accuracy; the red color indicates that accuracy parameters are not satisfied at the moment.



**Note.** Clicking on panel that reports the information on GPS you access to window **GPS Status**.

The requested data for recording of point are the following:

Field	
Point	Name of next point to measure
Code	Code to assign to next point to measure

In the lower part a toolbar allows to access to a menu of advanced functions and to commands for measuring points.

## Rapid measuring of points

Command	
 Measure-& Store	Measuring of current position and direct saving of the point.
 Stop	Allows to stop measuring.



The command starts the acquisition of position for the number of epochs set in survey parameters. The epochs are acquired if the condition imposed by the **Accuracy check** are satisfied; otherwise the software remains waiting until you stop it manually or until when conditions are satisfied. When reaches the number of epochs defined, the point is saved. The name of next point is automatically proposed.

**Note.** It's possible to stop measuring when the imposed conditions are not satisfied, and to proceed however with recording of point.

**Note.** For further information on **Accuracy check** see paragraph **Accuracy check** in this chapter.

**Note.** If to the code of the point has been associated a GIS feature it appears a window visualizing the attributes of the GIS feature that have to be filled in by the operator.

## Measuring of points

Command	
 Measure	Measuring of current position.
 Stop	Allows to stop measuring.

The command starts the acquisition of position for the number of epochs set in survey parameters. The epochs are acquired if the condition imposed by the **Accuracy check** are satisfied; otherwise the software remains waiting until you stop it manually or until when conditions are satisfied.

**Note.** It's possible to stop measuring when the imposed conditions are not satisfied, and to proceed however with recording of point.







**Note.** For further information on **Accuracy check** see paragraph **Accuracy check** in this chapter.

When reaches the number of epochs defined, the command follows with request of confirmation of following data:

Data page	
Point	Name of point to store

<b>Antenna elevation</b>	Elevation of the antenna at the moment of the acquisition of the point
<b>Code</b>	Code associated to the point. See paragraph <b>Assignment of survey codes</b> and <b>Quick codes</b> in chapter dedicated to <b>Survey codes</b> .
<b>Description</b>	Extended description associated to the point

### Sketch page

	Deletes sketch and photo.
	Restores original content.
	Adds a label with the main point information; the label can be moved to any position.
	Adds a label with free text; the label can be moved to any position.
	Adds an arrow symbol; the arrow can be moved and rotated.
	Active the free drawing mode.
	Starts application allowing to shoot a photo and save it.

### Results page

General information on point to record.

**Note.** If to the code of the point has been associated a GIS feature it appears a window visualizing the attributes of the GIS feature that have to be filled in by the operator.

### Accuracy check

Settings of the accuracy check allow to define control parameters to accept the epochs sent by the receiver; only when all condition imposed are satisfied the single epoch is accepted and the measuring of point proceeds.

		<b>Survey setup</b>	<b>GNSS page</b>	<b>GNSS Accuracy check</b>
---	---	---------------------	------------------	----------------------------

Field	Description
<b>Store only in Fixed</b>	Epochs recording is done only if receiver is in fixed position status.
<b>Accuracy check</b>	Activates accuracy check; the GPS epoch is accepted if current precision satisfies conditions of precision preset.
<b>H</b>	Maximum horizontal precision to make acceptable the GPS epoch
<b>V</b>	Maximum vertical precision (in elevation) to make acceptable the GPS epoch

<b>RTK age check</b>	Enables control of receiving RTK corrections. If it is active, corrections must be received within the time set to store the point.
<b>Max age (secs)</b>	Sets the maximum time that the new RTK fix needs to be received.
<b>DOP check</b>	Activates check on DOP value; the GPS epoch is accepted only if DOP value is lower than preset value.
<b>Max DOP</b>	Maximum DOP value to make acceptable the GPS epoch.
<b>Satellites check</b>	Activates the satellites number check; the GPS epoch is accepted only if the number of satellites tracked is more than minimum preset value.
<b>Minimum number of satellites</b>	Minimum number of satellites to make acceptable the GPS epoch.
<b>Sensors mode</b>	<p>It's possible to set the use of different types of sensors in surveying and stakeout phases:</p> <ul style="list-style-type: none"> <li>• <b>None:</b> no sensor</li> <li>• <b>E-bubble (controller):</b> activates the use of electronic bubble of the controller; the GPS epoch is accepted only if the electronic bubble is inside the tolerance range</li> <li>• <b>E-bubble (GPS receiver):</b> activates the use of electronic bubble of the GPS receiver (if present); the GPS epoch is accepted only if the electronic bubble is inside the tolerance range. Only for Zenith35 TAG.</li> <li>• <b>Tilted pole (GPS receiver):</b> activates the use of tilt and compass sensors of the GPS receiver (if present). Sensors allow to calculate the position of the point even if the pole is not vertical; only for receiver Zenith35 TAG and requests that calibration of internal compass has been made.</li> </ul>
<b>Max error (2m pole)</b>	Maximum error acceptable outside the bubble considering a 2 meters pole.
<b>Localization zone check</b>	<p>Activates the GPS localization zone check; if a coordinates system defined by a localization on more than 2 points is set, the software verifies if the receiver position is inside the localization zone; if current position is external to localization zone an icon on coordinates panel is visualized in survey and stakeout windows. The localization zone is drawn in the graphic window.</p> 

### Measuring of points with GeoMax Zenith35 TAG

The receiver GPS GeoMax Zenith35 TAG is equipped with sensors allowing to acquire points with two new modes not possible with traditional receivers:

Mode	Description
<b>E-Bubble</b>	Exploiting the internal inclinometer it can be visualized an <b>electronic bubble</b> directly on the screen; this way the operator can keep the attention on the display instead of constantly looking at the controller and the physical bubble placed on the pole. Moreover, the software is able to prevent the acquisition of the epochs when the pole is located in outside the bubble condition
<b>Dual</b>	Exploiting the internal inclinometer it's possible to perform a double measure of the point with inclined pole (up to and beyond 30 °) and determine the position of the point. This mode requires no system calibration and is not sensitive to external factors.

	To measure points with Dual mode refer to the following section <b>Hidden point with inclined pole</b> .
<b>Single</b>	Exploiting the internal inclinometer and the internal compass the system is able to determine the three-dimensional position and direction of the pole and to calculate the coordinates of the point on the ground even when the pole is inclined (up to 15 °). The system requires the compass calibration and may be subject to external factors such as magnetic fields generated by the elements present on the site to be surveyed. For more information on the calibration mode and the operating procedures to be followed in the field, see the documentation supplied with the receiver. To measure points with Single mode simply activate the <b>Tilted pole (GPS receiver)</b> option: in the settings for the <b>Accuracy Check</b> explained in the previous paragraph; before using this mode it's necessary that a calibration of the internal compass has been executed.

### Electronic bubble



Select item **E-Bubble (GPS receiver)** in correspondence of the item **Sensors mode**. In the Survey and Stakeout windows is visualized the bubble; during the phases of acquisition of the position, if the inclination of the pole is higher than the set tolerance the position is not acquired. Clicking on the electronic bubble it appears a menu allowing you to disable the use of the bubble, enable the calibration or switch to **Single** mode.

### Dual mode



This measuring mode allows to measure points without having to keep the pole vertical; It requires two inclined measuring to perform in two directions while keeping the tip of the pole on the point.

Step	Description
<b>First measure</b>	Place the tip of the pole on the point to measure; tilt the pole to a position that allows the receiver to fix the position. Do not go beyond 30/40 °. Press <b>Measure</b> to record the position.
<b>Second measure</b>	Always keeping the tip of the pole on the point and the pole inclined rotate around the point; on video it appears a circle that represents the first measure and a second circle which represents the second measure; act so that the two circles have an overlapping zone and two points of intersection. Press <b>Measure</b> to record the position.
<b>Calculation</b>	The intersections of the two circles are calculated. Bring back slightly the pole in a vertical direction to allow the software automatically select the intersection related to measured point. Press <b>Store</b> to accept the calculated point. If necessary you can perform a third measure always with the previous modes, going to improve the accuracy of the calculated data.

### Single mode



Select item **Tilted pole (GPS receiver)**: In the Survey and Stakeout windows is visualized the bubble; if the calibration is correct, the calculated position is always the position of the point on the ground at any angle (up to 15 °).

Clicking on the electronic bubble appears a menu allowing you to calibrate, disable the use of the bubble, switch to use of the bubble or go to **Dual** mode.

### Hidden points

The hidden points are positions in which the receiver GPS can't acquire precise coordinates due to lack or insufficient visibility of satellites. To acquire however position you are interested in they are used some artifices integrating to GPS position measures of distances and slopes.

Distances and difference in elevation between reference points and the point to measure can be acquired directly by laser Disto with Bluetooth system; after measuring distance hit button Bluetooth on device and the measured value will be transferred automatically in the distance field of the window. If you set the software to measure also the inclination angle they are transferred both distance and difference in elevation values.

To use the laser Disto it's necessary to create a corresponding profile in the instruments profiles.

### Measuring of hidden points by intersection of two distances

Calculates position of a point basing on two distances by two reference points.



A guided procedure allows to define the two reference points, the distances and choose the desired solution. They are requested data related to first reference point.

First point (A)	
Reference point (A)	Specify the name of first reference point; it's possible to type the name of the point ore select it from graphic window or from table.
	If the reference point hasn't been measured yet allows to proceed to measure and to saving of point
Distance from A	Allows to measure the reference point.
Height difference from A	Elevation difference of point to measure from reference point.
Laser elevation	Elevation from the ground of laser Disto; this way it's possible to determinate the exact value of the slope from the reference point.

Hit **Next** to proceed with guided procedure.

Second point (B)	
Reference point (B)	Specify the name of second reference point; it's possible to type the name of the point ore select it from graphic window or from table.

	If the reference point hasn't been measured yet allows to proceed to measure and to saving of point
<b>Distance from B</b>	Allows to measure the reference point.
<b>Height difference from B</b>	Elevation difference of point to measure from reference point.
<b>Laser elevation</b>	Elevation from the ground of laser Disto; this way it's possible to determinate the exact value of the slope from the reference point.

Hit **Next** to proceed with guided procedure. The calculation is performed and they are visualized in a graphic window the two reference points and the two possible solutions. Choose the desired solution clicking in correspondence of the semi-plane to which the solution RIGHT or LEFT belongs. The solution that will be used is represented in red.

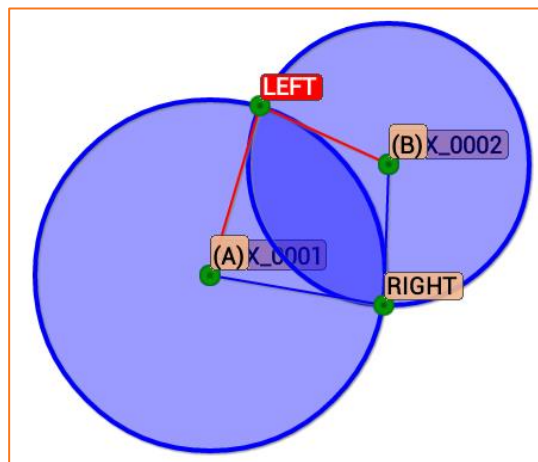



The calculation scheme and the measured point can be visualized also on Google map.





**Note.** At the moment to choose the solution we suggest to approach the receiver toward the point to measure; the position of receiver is visualized on graphic window allowing to understand which of the two solutions is the desired one.

Hit **Next** to proceed with guided procedure. They are request the data of the measured point by intersection of two distances:

Data page	
<b>Point</b>	Name of point to record
<b>Antenna elevation</b>	Elevation of the antenna at the moment of the acquisition of the point
<b>Code</b>	Code associated to the point. See paragraph <b>Assignment of survey codes</b> and <b>Quick codes</b> in chapter dedicated to <b>Survey codes</b> .
<b>Description</b>	Extended description associated to the point

Sketch page	
	Deletes sketch and photo.
	Restores original content.



	Adds a label with the main point information; the label can be moved to any position.
	Adds a label with free text; the label can be moved to any position.
	Adds an arrow symbol; the arrow can be moved and rotated.
	Active the free drawing mode.
	Starts application allowing to shoot a photo and save it.

### Results page

General information on point to record.

At the end of recording it's possible to decide if continuing to measure other hidden points or returning to main measuring window.

### Measuring of hidden points by alignment and offset

Calculates position of a point referring to an alignment defined by two reference points.



A guided procedure allows to define the two reference points, the distance and position referring to an alignment and check the desired solution. They are requested data related to two reference points.

### Reference points

<b>Reference point (A)</b>	Specify the name of first reference point; it's possible to type the name of the point ore select it from graphic window or from table.
<b>Reference point (B)</b>	Specify the name of second reference point; it's possible to type the name of the point ore select it from graphic window or from table.
	If the reference points haven't been measured yet allows to proceed to measure and to saving of points

Hit **Next** to proceed with guided procedure.

### Distance & Offset

<b>Reference</b>	Reference distance along the alignment can be referred to starting point (A) or ending point (B).
<b>Distance from B</b>	Distance along the alignment, and referred to point A or B, of the projection of the point to measure.
<b>Offset</b>	Distance of the point to measure in reference with defined alignment; position of the point referring to alignment (left or right) is decided after in the graphic window.

<b>Height difference from B</b>	Elevation difference of the point to measure referring to reference point A or B.
<b>Laser elevation</b>	Elevation from the ground of laser Disto; this way it's possible to determinate the exact value of the slope from the reference point.



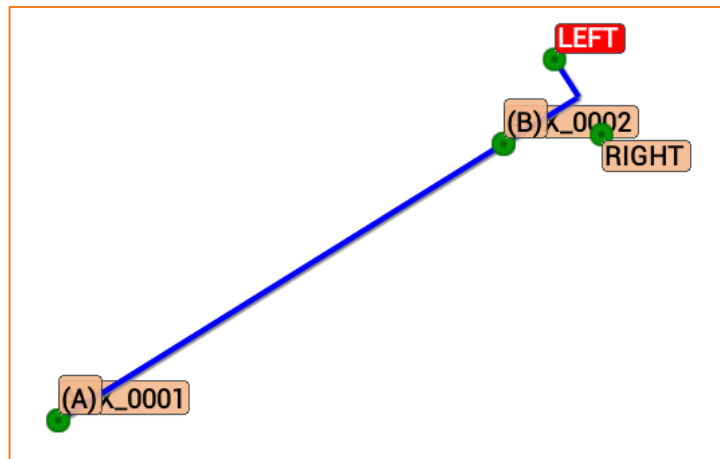

Hit **Next** to proceed with the guided procedure. It's executed the calculation and are shown in the graphic window the two reference points and the two possible solutions: to the right or to the left referring to the alignment. Select desired solution clicking on the semi-plane containing solution LEFT or solution RIGHT. Solution selected that will be used is represented in red color.



**Note.** At the moment to choose the solution we suggest to approach the receiver toward the point to measure; the position of receiver is visualized on graphic window allowing to understand which of the two solutions is the desired one.

Hit **Next** to proceed with guided procedure. They are request the data of the measured point by alignment and offset:

Data page	
<b>Point</b>	Point
<b>Antenna elevation</b>	Antenna elevation
<b>Code</b>	Code
<b>Description</b>	Description

Sketch page	
	Deletes sketch and photo.
	Restores original content.
	Adds a label with the main point information; the label can be moved to any position.
	Adds a label with free text; the label can be moved to any position.
	Adds an arrow symbol; the arrow can be moved and rotated.



Active the free drawing mode.



Starts application allowing to shoot a photo and save it.

### Results page

General information on point to record.

At the end of recording it's possible to decide if continuing to measure other hidden points or returning to main measuring window.

### Recording of raw data during survey

In cases where you don't have your own base and it's not possible the connection to a network of permanent stations, it's possible to exploit a feature present in most part of receivers allowing to record all survey session data in a file of proprietary format or in standard format as RINEX. These data can be used in post-processing elaborations in the office to obtain precise coordinates.



Start Log

Command starts recording of raw data on receiver; in this file created by the receiver will be present the measured points with all the kinematic chain. The file of the receiver, at the end of the survey, must be transferred for a post-processing with a dedicated software which will provide compensated coordinates.

A window allowing to define some parameters necessary to perform the memorization of data of the session by the receiver. Such requests can be different basing on receiver model.

### Survey – Post-Processing

<b>Log file</b>	Name of the file on which memorizing the raw data
<b>Occupation time</b>	Time of acquisition of single point
<b>Logging rate</b>	Frequency with which recording data for post-processing.
<b>File type</b>	Sets the file's type to store.
<b>Antenna height</b>	Sets the height of antenna to store.

Recording of raw data is stopped automatically when the survey of points procedure ends or it can be interrupted in every moment.



Stop Log

### Automatic survey of points

Automatic surveying allows to acquire automatically the positions of the points basing on elapsed distance or elapsed time rules.



SURVEY

Auto-Survey of points

Before starting to acquire points it's possible to set functioning parameters and rules.

### Survey Auto

#### Mode

Mode to use for automatic survey of points:

- **Time:** position is acquire at preset intervals of time
- **2D distance:** position is acquired at preset intervals of horizontal distance
- **3D distance:** position is acquired at preset intervals of 3D distance
- **Distance 2D Plus:** position is acquired at preset intervals of horizontal distance and height difference according to settings.
- **Stop & Go:** position is acquired in stop & go mode; when the antenna remains in still position the software begins to acquire position.

### GPS – Auto survey – Time mode

#### Measure every (sec)

Set the interval of time between every automatic acquisition of position

### GPS – Auto survey – 2D Distance

#### Distance 2D

Set the interval of horizontal distance that must be between position to acquire and previously acquired position.

### GPS – Auto survey – 3D Distance

#### Distance 3D

Set the interval of 3D distance that must be between position to acquire and previously acquired position.

### GPS – Auto survey – 2D plus

#### Distance 2D

Set the interval of horizontal distance that must be between position to acquire and previously acquired position. The point is stored when one of the set values is overpassed.

#### Height difference

Set the interval of height difference that must be between position to acquire and previously acquired position. The point is stored when one of the set values is overpassed.

### GPS – Auto survey – Stop & Go

#### Stop time (sec)



Defines the time spent on the point to allow the acquisition of the position.

#### Max. movement antenna

Maximum movement allowed to consider the antenna still; when the software recognize that the antenna remains almost still with a movement less than maximum value, it begins acquisition of position for the preset stop time.

**Note.** The window functions in the same way of the simple surveying window. For further information please refer to previous chapter **Survey of points**.

## Startup of the automatic measuring

Command	
 <b>Start Auto</b>	Starts automatic measuring of points. The point number is automatically increased at every recorded point.
 <b>Stop</b>	Allows stopping measuring.

Position is acquired if conditions set in **Accuracy check** are satisfied; otherwise the software remains waiting until a manual stop or till when conditions are satisfied.

The command recognizes automatically when condition for recording is reached evaluating time elapsed or the distance elapsed; when reaching condition of recording the point is recorded.

---

## Static survey

This command allows to record static data of the position of the receiver for a further elaboration with post-processing software allowing to determinate precise coordinates.





When starting the command it appears a window allowing to define some parameters necessary to execute recording of data of the session by the receiver.

Survey – Post-Processing	
<b>Log file prefix</b>	Prefix to assign to the log file that will contain data of the occupation. It's created a file for every point; the name of the file comes from the composition of the prefix and of the name of the point. The log files are recorded inside the receiver and have to be therefore transferred in to the PC with the specific cable. The files have to be then transformed in RINEX files using the specific STH2RINEX application.
<b>Logging rate</b>	Frequency with which to record data for post-processing.
<b>Occ. time</b>	Occupation time of the point; it's possible to set a default time or to choose the <b>Custom</b> option. In this case the stop of the occupation of the point has to be made by the user.
<b>File type</b>	Sets the file's type to store.
<b>Antenna height</b>	Sets the height of antenna to store.

Hit **Next** to proceed and go to the window of static measuring of points. Functioning of the window is the one explained in the two previous chapters, **Survey points** and **Auto-survey points**.

## Starting occupation

Command
---------

 <b>Start occupation</b>	Starts static measuring of the position. Receiver begins data recording inside the controller or in its internal memory.
 <b>Stop occupation</b>	Allows to stop measuring.

If it has been defined the time of occupation it will be shown a counter of the time remaining to completion of the procedure; otherwise it's shown a counter of the time elapsed from the beginning of the occupation.

At the end of the occupation or after a stop the command asks a confirmation of the data of the point.

## Bathymetric survey

### BATHYMETRY

Bathymetry is a module of X-PAD Survey software that enables bathymetric survey by using an echosounder and a GPS receiver. The software is able to connect to the echosounder through Bluetooth and receive in real time the depths; at the same time the accurate positions are given by the GPS receiver placed just over the echosounder. It is possible to record automatically positions and depth by defining a time interval, a distance or a depth interval; current depth and the longitudinal profile of the bottom are displayed in real time through a specific panel.

To be sure to cover all the area without missing any detail, it is possible to define routes and have on the screen all the necessary information to keep the right direction. A route can be a line or a polyline that can be simply selected on the screen. Another way to define a route is enter an azimuth value as reference direction to follow. Collected data can be exported in customizable ASCII format or AutoCAD DXF drawing.

	<b>SURVEY</b>	<b>Bathymetric survey</b>
---	---------------	---------------------------



The bathymetric survey acquires continuously the GPS position and depth according to rules of distance or elapsed time. The GPS must be positioned in correspondence of the echosounder.

### Bathymetric survey

**Mode** Mode to use for the automatic survey of points:

	<ul style="list-style-type: none"> <li>- <b>Time:</b> the position is acquired at fixed intervals of time</li> <li>- <b>2D distance:</b> the position is acquired at fixed intervals of horizontal distance</li> <li>- <b>Depth:</b> the position is acquired at fixed intervals of difference in depth</li> </ul>
<b>Route tolerance</b>	Sets the distance from the route within navigation arrow shows the distance from the route. If the value will be overpassed the software shows the direction to come back in the route.

### Bathymetric survey – Time mode

<b>Measure every (sec)</b>	It defines the time interval between the positions of the automatic acquisition.
----------------------------	--

### Bathymetric survey – 2D distance

<b>Measure every</b>	It defines the horizontal distance interval that must elapse between the position to be acquired and the position acquired previously.
----------------------	--



### Bathymetric survey – Depth

<b>Measure every</b>	It defines the depth interval that must elapse between the depth to be acquired and the depth acquired previously.
----------------------	--

## Start of the bathymetric survey

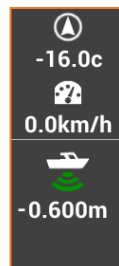
In the window they are visualized in real time the values of speed, direction and depth. It's also visualized the bottom contours during the survey.



Command	
<b>Sessions</b>	Assign the name to bathymetry session
 <b>Start session</b>	Starts session of the bathymetric survey.
 <b>Stop</b>	Allows to stop the session of the bathymetric survey.

## Setting the fixed route

It's possible to set a route direction (azimuth) you want to follow. During the survey a new panel appears that allows to maintain the predetermined route.

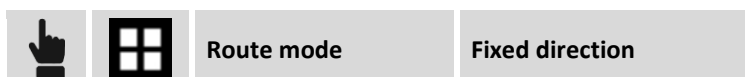

## Route setting from drawing element

The route to follow can be represented by drawing elements (lines and polylines).

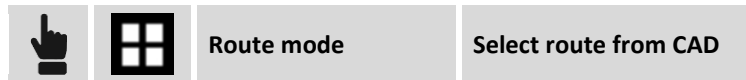

Select a line or a polyline from the graphic window. The selected item becomes the reference element to follow; the panel with the indications of the route shows exactly the direction to be maintained in order to remain in the selected route.

## Cancel route



The command deletes the set route.

## Store points and measurements

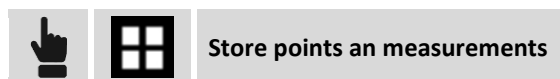

The command stores every single point of the bathymetric session as a point and measurement of the GNSS survey.

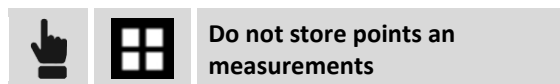

Disable storing of bathymetric session points as points and measurements of GNSS survey.

## Create surface

The command creates a surface based on selected sessions.

## Add a note

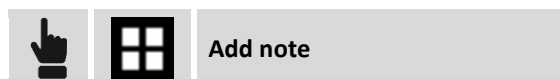

During the bathymetric survey operations, it is possible to add descriptive notes and sketches that can be a valid reference when processing the stored data in the office.

## Survey setup

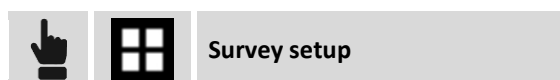

During survey operation, it is possible to access receiver settings. For further information, please refer to the **Settings** chapter.



## Visualizing the survey sessions

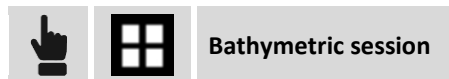

It's visualized the list of bathymetry sessions executed; selecting a session it's possible to access additional information or delete it.

## Exporting the survey sessions

Data of the bathymetry sessions can be exported in ASCII format.



---

## Survey with locators (cable detectors)



The methodology of GPS survey with Locators is the same as the standard GPS survey. You must have defined an active Locator profile that will be used to acquire the depth values.



If the locators profile is active in the GPS survey window appears a bar similar to the following.

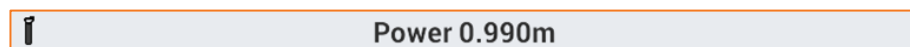

Press the LOG key of the locator to send the measured value of depth to the software on the controller; The software captures the depth and stores a new point using the current GPS position.

# GPS - Stakeout

**GPS**

Stakeout procedures allow to provide to the operator the information in graphic, numeric and vocal format, to reach a point, an element or in general a particular position. A wide range of options and operative modes are available.

Before proceeding with stakeout it's necessary to define with precision the coordinates system of the job in order to guarantee the correct matching between surveyed positions and positions to stakeout. If no coordinates system is set you can perform only stakeout of positions defined in WGS84 coordinates.



**Note.** Commands to measure points are available when a GPS instrument profile has been set in **ROVER** mode.



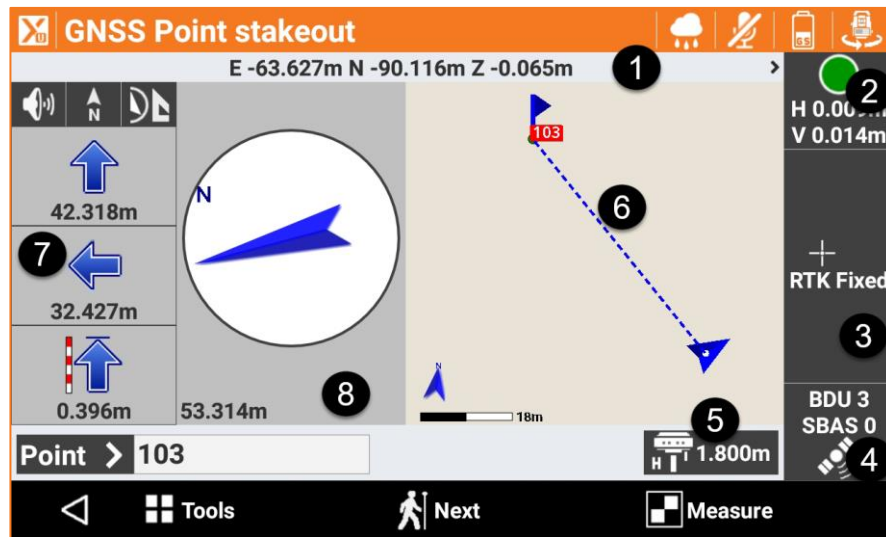



## Stakeout information

Information provided by the software during stakeout of a position are quite common and similar in all modes; whether you are doing stakeout of a point, of an element or of a position by offset, the software provides indications to reach position to stakeout using a common scheme.



The stakeout window presents some panels on external borders reporting different information concerning receiver status and allowing to manage the different available functions.

Panel	Title	Description
1	Coordinates	The panel reports the geographic coordinates (latitude, longitude, Elevation) of receiver; clicking on panel you pass to visualization of plane coordinate (East/North/Elevation). Clicking you return again to geographic coordinates.
2	Accuracy	The traffic light,  or  , indicates if the precision level set in the survey parameters, has been reached; the epochs are acquired only when the level of precision has been reached (horizontal and vertical precision, minimum number of satellites, maximum values of DOP, electronic bubble).

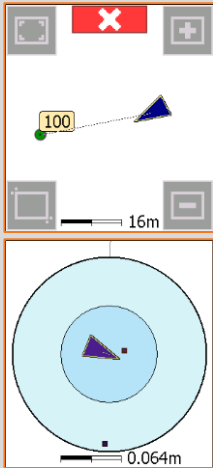
		Under the traffic light they are reported the current precision values for coordinates (H) and for elevations (V).
3	Receiver status	 <b>RTK Fixed (Safe mode):</b> receiver is receiving corrections from a source and it has fixed the ambiguity in Safe mode (maximum precision and security); only for Zenith35 receiver.
		 <b>RTK Fixed:</b> receiver is receiving corrections from a source and it has fixed the ambiguity (maximum precision)
		 <b>Quick Fix:</b> receiver has fixed the ambiguity but it hasn't still reached the maximum precision level; only for receiver Zenith25.
		 <b>RTK Mobile:</b> receiver is receiving corrections from a source but it has not yet fixed ambiguity
		 <b>DGPS:</b> receiver is receiving differential corrections in DGPS mode.
		 <b>Autonomous:</b> receiver is acquiring position in autonomous way without receiving corrections from any source (minimum precision)
4	Satellites	 <p>Number of satellites, for the different constellations, currently tracked.  <b>GPS:</b> constellation GPS  <b>GLS:</b> constellation GLONASS  <b>BDU:</b> constellation BeiDou/Compass  <b>SBAS:</b> constellation SBAS</p>
5	Elevation of the antenna	Elevation of the antenna of receiver. Clicking on panel it's possible to change the elevation.
6	Graphic area and Current position	 <p>Graphic visualization of the current position and of the position to reach. If the symbol is blue it means that all parameters of operation satisfy the preset level of accuracy; red color indicates that precision parameters are not satisfied at the moment.</p>



7		<p>Numeric indications to reach position. Indications are referred to the <b>North</b> or to the <b>Sun</b> or to <b>reference point</b>.  First value is referred to distance <b>Forward-Backward</b>.  Second value is referred to distance <b>Right-Left</b>.  Third value specifies the <b>elevation</b> difference.</p>
8		<p>This panel shows a compass indicating, with respect to the current direction, the direction of the position to reach. In the lower part is reported the distance of the point  This view mode is when you are at more than a meter distance from the position to reach.  The arrow of the compass is red when receiver hasn't reached yet the precision check preset.  In stakeout settings it's possible to define the distance limit stating when to use this type of visualization; the value of default is set at one meter.</p>
8		<p>When distance from the position to reach is less than one meter it appears this view mode. Indications provided and position indicated are referred to position of the <b>North</b> or to position of the <b>Sun</b>.</p>
8		<p>Background become green when you reach, inside tolerance values, requested position.</p>

**Note.** Clicking on panel reporting information on GPS you access to window of **GPS Status**.



### Stakeout tolerance



Reaching of position happens when the distance between current position and the position to reach is less or the same as **Stakeout tolerance**. Stakeout tolerance is set in the **Stakeout parameters**. From every stakeout procedure it's possible to enter in the stakeout parameters and to check tolerance value.

### Information referring to North or to Sun or to a reference point

The information provided in the panel on the right are referred to the North, to the Sun or to a reference point. To read properly the distance values it's necessary therefore turning toward the North, toward the Sun or toward the reference point. Buttons    allow to change the reference element.

## Graphic and analytic view



To move from analytic to graphic view use buttons   .

Command	
	Enables display of analytical mode only, which indicates the distance from the point.
	Enables the graphic window display.
	Enables the mixed display that shows distance from the point and the graphical window.

## Vocal information

The software guides the user with vocal information allowing, most of all when you are far from the point, to arrive near the point without having to look always on the controller.

A tone tells when is reached, inside preset tolerance limits, the desired position.

To enable and disable vocal information use buttons  .

## How to interpret information provided

After having defined the position to reach we suggest to follow the following two rules to reach position in the most speedy and effective way.

1. When you are far from the point follow vocal indications even without looking always on the controller display; it's sufficient to listen what the software indicated about arriving directly near the position to reach.
2. Once you are arrived near the position, at a distance less than one meter, turn with the controller toward the North or toward the Sun, depending on the type of reference you chose. Move the antenna following indications present on the right side panel. A tone tells you when you reach position.



---

## Common operations in Stakeout

All stakeout operations have common operations and functions that are reported below.

### Measuring the point

After having reached the stakeout position it's possible to record the point.

Command	
 Measure	Starts measuring of stakeout point.
 Stop	Allows to stop measuring.

The command starts acquisition of the position for the number of epochs preset in surveying parameters. Epochs are acquired if conditions set in **Accuracy check** are satisfied; otherwise the software remains waiting until a manual stop or till when conditions are satisfied.

**Note.** For further information about **Accuracy check** see **Accuracy check** and **Stakeout parameters** in this chapter.

When reached the preset number of epochs the command proceeds showing some stakeout data: Hit **Next** to proceed and complete measuring with definition of data of the point to record. Stakeout data are saved and it's possible to read and export them from window **Stakeout Report**. The next point to stakeout is automatically proposed by the software.

### Stakeout parameters

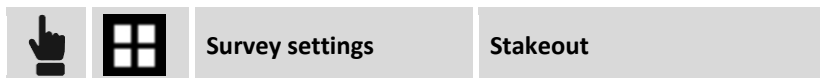

Field	Description
<b>Distance tolerance</b>	Maximum horizontal distance between current position and position to reach to consider being on stakeout position; if the distance between current position and position to reach is lower or equal to tolerance, the software reports the reaching of stakeout position.
<b>Elevation tolerance</b>	Maximum acceptable difference between current elevation and stakeout elevation; if the elevation difference is lower or equal to tolerance the software reports the reaching of the position in elevation.
<b>Vocal info</b>	Activates the vocal information during the stakeout operations.
<b>Confirm before saving</b>	Allows checking the stakeout position before proceeding to saving new point on position to stakeout. Disabling this option the stakeout point is saved without any further request.
<b>Reference GNSS</b>	Defines reference referring to which the information to reach the stakeout position with the GPS are provided. References can be: <ul style="list-style-type: none"> <li>- <b>North</b>: information are provided referring to the North; turn the controller toward the North and follow indications.</li> <li>- <b>Sun</b>: information are provided referring to the Sun; turn the controller toward the Sun and follow indications.</li> <li>- <b>Point</b>: information are provided referring to a reference point previously defined; turn the controller toward the point and follow indications.</li> </ul>
<b>Compass limit</b>	Distance determining the automatic change of visualization of the stakeout information; if the distance of the receiver from the point to stakeout is more than the defined value it appears the arrow indicating direction; if the distance of the receiver from the point to stakeout is lower than the defined value it appears the stakeout sketch with the reference to <b>North</b> , to <b>Sun</b> or to <b>Point</b> .

Hit **End** to save modifications.

### Inserting a note

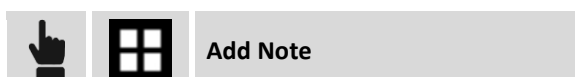

During stakeout it's possible to add in the field book some notes and sketches that can be helpful when working on acquired data in the office.

### Points & Measurements



Points & Measurements

It's possible to access to management of measurements and points during stakeout. For further information referring chapter **Point, measures, survey codes and GIS features managing**

### Reference surface

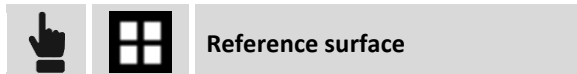

Reference surface



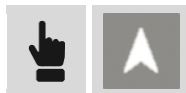

It is possible to set a reference surface during stakeout. In this way the software will display the elevation difference between the current position and the corresponding elevation on the reference surface.

Field	Description
Surface	Set the surface to display.
Display surface	Enables/disables the display of the surface.

### Automatic updating of the view



This command allows you to enable and disable the automatic update of the view based on the current position of the receiver; when the option is enabled the graphic view is updated so that the receiver position is always visible. It is possible set one of the following options:

Option	Description
 	Enables the automatic update of the view oriented according to direction of the receiver. According to the reference set (North, Sun, Reference point).
 	Disables the automatic update of the view.

### Stakeout of points

The stakeout of points procedure allows the operator to define, in different modes, the position to reach and to be guided by the software on the position to reach in the fastest way possible.



STAKEOUT

Points

Select mode	
<b>Point from CAD</b>	Select the point to stake directly from graphic window
<b>Point from table</b>	Select the point to stake from list of points
<b>Automatic by position</b>	Automatically select the nearest point to stake out according to position of the receiver .
<b>Define points list</b>	Allows to create a list of topographic points to stake.
<b>Coordinates</b>	Manual definition of coordinates East, North and Elevation to stake. Coordinates can be selected from the CAD drawing.
<b>Coordinates WGS84</b>	Manual definition of the WGS84 coordinates to stake.
<b>Coordinates ECEF</b>	Manual definition of the geocentric coordinates to stake.



### Stakeout of a list of points



It appears a window in which the button **Tools** allows to execute main operations.

Tools	
<b>Load all points</b>	Loads in the list all the topographic points present in the job.
<b>Load all reference points</b>	Loads in the list all reference points present in the job
<b>Select from table</b>	Allows to select from the table topographic points to add to the list.
<b>Select from CAD</b>	Allows to select from the graphic window topographic points to add to the list.
<b>Delete points</b>	Allows to select from the list the points to delete.
<b>Clear list</b>	Deletes content of the list.
<b>Load list from file</b>	Allows to load the list from a file of points previously created.
<b>Save list to file</b>	Saves the list of points on an external file to be loaded later.

Selecting a point from the list you can change its position inside the list or delete it from the list. The icon aside every point identifies if the point has been still staked.

Icon	
	Point of the list that has been still staked.
	Point of the list not yet staked.



## Stakeout of coordinates ENZ

ENZ Coordinates	
E/N/Z	Coordinates of the position to stake.
	Hit <b>Select</b> to define coordinates by selecting on the drawing of the graphic window.

## Stakeout of WGS84 coordinates

WGS84 Coordinates	
Latitude, Longitude, Elevation	Geographic coordinates of the position to stake.

## Stakeout of coordinates ECEF

ECEF Coordinates	
E/N/Z	Coordinates of the position to stake.
	Hit <b>Select</b> to define coordinates by selecting on the drawing of the graphic window.

## Stakeout procedure

After having defined position to stake it appears the main stakeout window.

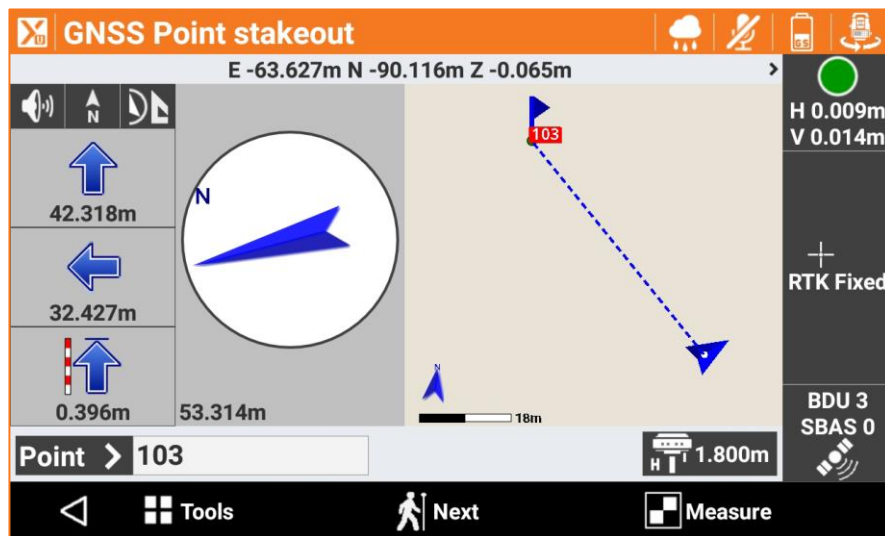

## Stakeout of the next point



It's possible to choose the next point to stake in following modes:

Next point to stake	
Next	It is selected the next point, according to recording order, to current point.

<b>Previous</b>	It is selected the previous point, according to recording order, to current point.
<b>Nearest</b>	It is selected the nearest point, which hasn't been yet staked, to current point.
<b>From CAD</b>	Manual selection of the point to stake in the graphic window.
<b>From Table</b>	Manual selection of the point to stake from the table.

## Stakeout of lines/arcs/objects

This procedure allows to position with precision along geometric elements as lines, arcs or drawing elements.



It's possible to define the element to stake in different modes.

Reference	
<b>Type</b>	Allows to choose mode to define element to stake. Possible options are: <b>Line (2 points)</b> : line defined by two reference topographic points. <b>Arc (3 points)</b> : arc defined by three reference topographic points. <b>Arc (2 points +R)</b> : arc defined by two topographic points and by the radius. <b>Drawing object</b> : drawing element (line, polyline, arc, circle) to select in the graphic window.

### Stakeout of line by 2 points

Line by 2 points	
<b>Point 1</b>	First point of the reference line
<b>Point 2</b>	Second point of the reference line
<b>Invert</b>	Inverts the direction of the line.
<b>Info</b>	Shows the information of the object.

### Stakeout of arc by 3 points

Arc by 3 points	
<b>Point 1</b>	First point of the reference arc
<b>Point 2</b>	Second point of the reference arc
<b>Point 3</b>	Third point of the reference arc
<b>Invert</b>	Inverts the direction of the arc.
<b>Info</b>	Shows the information of the object.

## Stakeout of arc by 2 points and radius

Arc by 2 points and radius	
Point 1	Starting point of the reference arc
Point 2	Ending point of the reference arc
Radius	Radius of the reference arc
Clockwise arc	Direction of the reference arc
Invert	Inverts the direction of the arc.
Info	Shows the information of the object.

## Stakeout of CAD element

It's requested to select from the graphic window the drawing element to stake.

## Offset

After defining the stakeout element it's possible to specify an additional offset, to the right or to the left.

Offset	
Offset	Distance to observe referring to reference element

## Multiplier

The command activates the stakeout of multiple offsets according to the set value of reference offset. When the option is active, the software shows the distance from the nearest offset and displays the multiplication factor of the offset distance.

## Stakeout procedure

After having defined the element to stake it appears the main stakeout window.

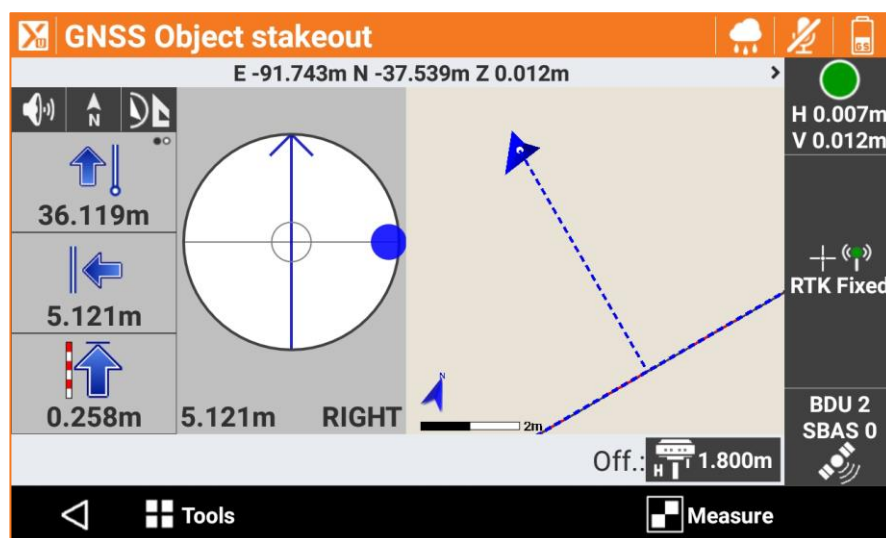

In the lower part is reported the station distance and the current distance referring to the element to stake.

## Information of stakeout

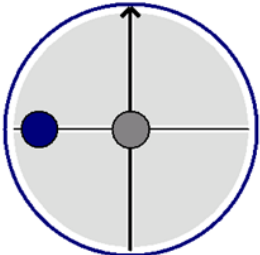
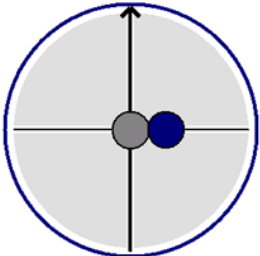
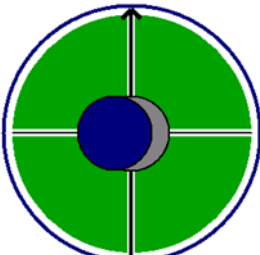
 <p><b>LEFT</b>      <b>-0.685m</b></p>	<p>Current position is on the left referring to the reference element.</p>
 <p><b>RIGHT</b>      <b>2.406m</b></p>	<p>Current position is on the right referring to the reference element.</p>
 <p><b>-0.012m</b></p>	<p>Current position is on the reference element.</p>

## Stakeout of station & offset

This procedure allows to execute stakeout of a position calculated referring to a station distance and to an offset distance on a reference element.



It's possible to define the reference element in different modes.

Type	
<p>Type</p>	<p>Allows to choose mode to define element to stake. Possible options are:  <b>Line (2 points)</b>: line defined by two reference topographic points.  <b>Arc (3 points)</b>: arc defined by three reference topographic points.  <b>Arc (2 points +R)</b>: arc defined by two topographic points and by the radius.  <b>Drawing object</b>: drawing element (line, polyline, arc, circle) to select in the graphic window.</p>

### Stakeout by offset referring to a line by 2 points

Line by 2 points	
<b>Point 1</b>	First point of the reference line
<b>Point 2</b>	Second point of the reference line
<b>Invert</b>	Inverts the direction of the line.
<b>Info</b>	Shows the information of the object.

### Stakeout by offset referring to an arc by 3 points

Arc by 3 points	
<b>Point 1</b>	First point of the reference arc
<b>Point 2</b>	Second point of the reference arc
<b>Point 3</b>	Third point of the reference arc
<b>Invert</b>	Inverts the direction of the arc.
<b>Info</b>	Shows the information of the object.

### Stakeout by offset referring to an arc by 2 points and radius

Arc by 2 points and radius	
<b>Point 1</b>	Starting point of the reference arc
<b>Point 2</b>	Ending point of the reference arc
<b>Radius</b>	Radius of the reference arc
<b>Clockwise arc</b>	Direction of the reference arc
<b>Invert</b>	Inverts the direction of the arc.
<b>Info</b>	Shows the information of the object.

### Stakeout by offset referring to a CAD element

It's requested to select from the graphic window the reference drawing element.

### Offset parameters

Parameters	
<b>Chainage</b>	Distance, on the reference element, at which is the position to reach.
<b>Interval</b>	Distance along the reference element that you want to maintain between the next stakeout points. The button on the right allows to calculate the interval dividing the length of the reference element in a defined number of parts.
<b>Offset</b>	Distance referring to reference element; the button aside allows to define if the desired position is on the right or on the left of the reference element.
<b>Height diff.</b>	Elevation difference to apply to the calculated point; the software interpolates the elevation on the reference element with the defined station distance. To the interpolated elevation can be added a slope.

Hit **Next** to start with stakeout of the calculated position.

### Stakeout procedure

After having defined the reference element and the offset parameters it appears the main stakeout window.

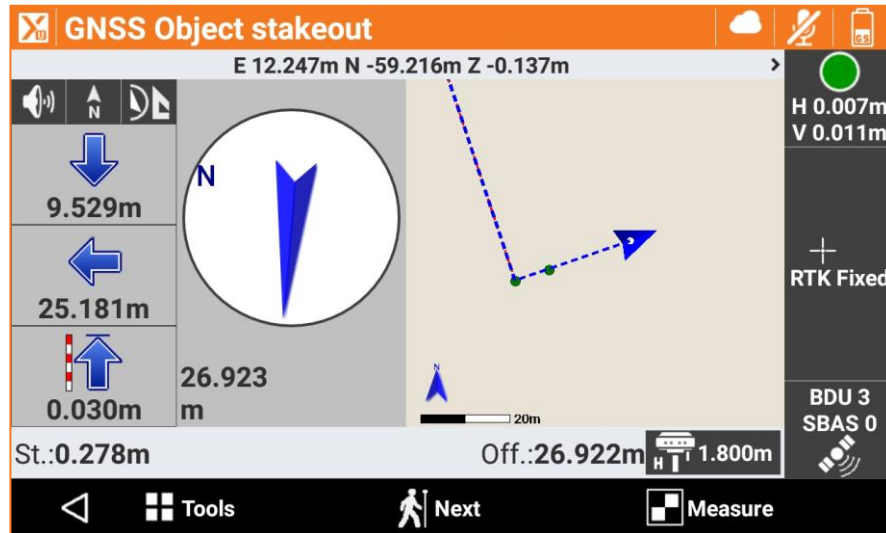

In the lower part is reported the station distance and the offset of the position.

### Stakeout of the next point by offset



Comes back to page allowing to define the station distance and the offset on the stakeout element. It is proposed a station distance increased of the interval value.

### Stakeout of sideslopes

This procedure allows to perform the calculation and the stakeout of the point of intersection of the project sideslope with the existing terrain; the position is calculated basing on a slope of project and compared to a chainage and to a distance (offset) of a reference element.



The requests that are performed are exactly the same seen in the previous paragraph and on the stakeout by offset. To the previous requests it's added a final tab allowing you to define the slopes of the project in the cut and fill conditions:

### Slopes

Slopes	
Cut	Slope value in the cut condition (receiver elevation above the starting elevation of the slope).



Fill

Slope value in the fill condition (receiver elevation under the starting elevation of the slope).

### Stakeout procedure

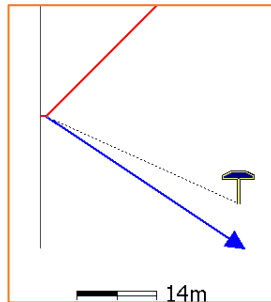
After defining the reference element, the offset parameters and slopes, it appears the main stakeout window.



In addition to the visualization mode analyzed in previous paragraphs, this procedure provides a graphical view of the cross section which shows the drawing of the project sideslope and current position. To change the visualization mode use the buttons   and .

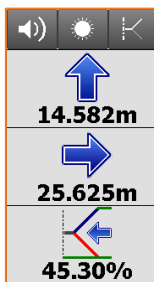

The side panel contains the information to get the point of intersection; The last information shows the current value of the slope and the direction to take, on the perpendicular to the reference element, to achieve the project slope value.

The last part of the panel can show the following information:

- Slope.
- Vertical distance from the position to project sideslope.
- Horizontal distance from the position to project sideslope.

It is possible to change the showed information, simply hit it or scroll.

### Stakeout of surfaces

#### VOLUMES

This procedure allows to determinate on field the design elevation of a three-dimensional surfaces loaded in current job; for every position the elevation of current position is compared with the elevation interpolated on surface and is calculated the difference of elevation. The surfaces stakeout can be used for:

- Stakeout on field of a planned surface
- Quality check to test the correspondence between the built and the plan.



Select surface to stake among the ones loaded in the job.

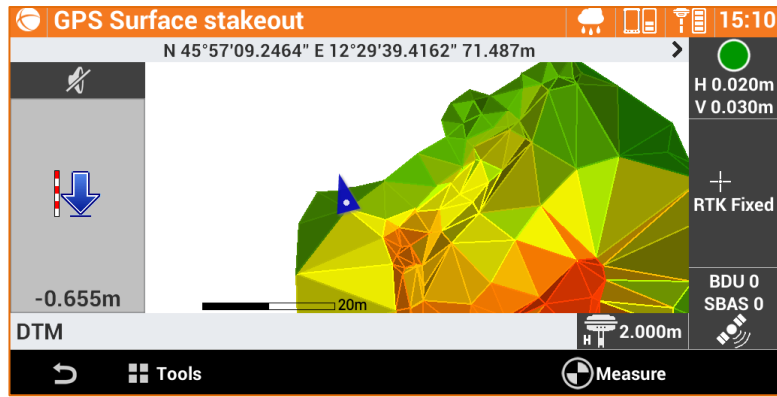

The side panel visualizes in real time the difference of elevation between current position and the elevation interpolated on the surface.

---

## Stakeout report

All the stakeout data, both related to stakeout of points, both to stakeout of elements, are recorded in the job. This command allows their reading and exporting in a file with CSV extension that can be opened also with software as Microsoft Excel.



A table present the list of all the stakeout points with differences, in distances and elevations, between the design coordinate and the stakeout coordinate.

Hit button **Share** to create a file, in ASCII, CSV, XML or PDF document, with all stakeout data of every point.



---

## TPS - Controlling the total station

### TPS

In this chapter it's explained how to modify main parameters of the total station as for example the type of target, the mode of measure; for the robotic total station it's explained how to perform the research of prism, how to control the direction of the station.





Following functions are activated by all the windows of the commands of survey and stakeout with total station.

---

### Mechanic total station control panel



This panel allows to control the basic functions of mechanic total station.

Command	
	Standard measure mode.
	Fast measure mode.
	Tracking measure mode (continuous measure).
	Activates visualization of the bubble.
	Visualizes the activation status of remote control. Activate remote control if you are using the controller on the pole. Deactivate remote control if you are using the controller from total station.

---

### Control panel of robotic total station







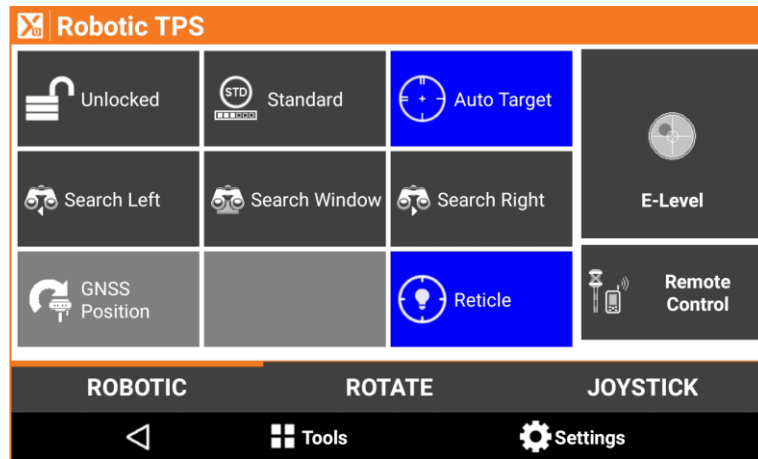

#### ROBOTIC

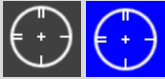

This panel allows to have full control of all functions of the robotic total station.

## Robotic page



Command	
	Status of locking of prism. Clicking on button it's started the research of prism.
	Current measure mode. They are available three status: Standard, Fast, Tracking (continuous measuring)
	Automatic aiming of prism. Clicking on button you activate and deactivate the automatic aiming of prism.
	Starts the automatic research of prism toward left.
	Starts the automatic research of prism inside a window defined. If the window hasn't been defined yet it's possible proceeding to definition of limits of the research zone.
	Starts the automatic research of prism toward right.
	Starts automatic prism search using the GPS position of the receiver placed over the pole (X-Pole).
	Activates the lights for the direction of stakeout.
	Activates visualization of the bubble.



Visualizes the activation status of remote control. Activate remote control if you are using the controller on the pole. Deactivate remote control if you are using the controller from total station.

## Rotation page

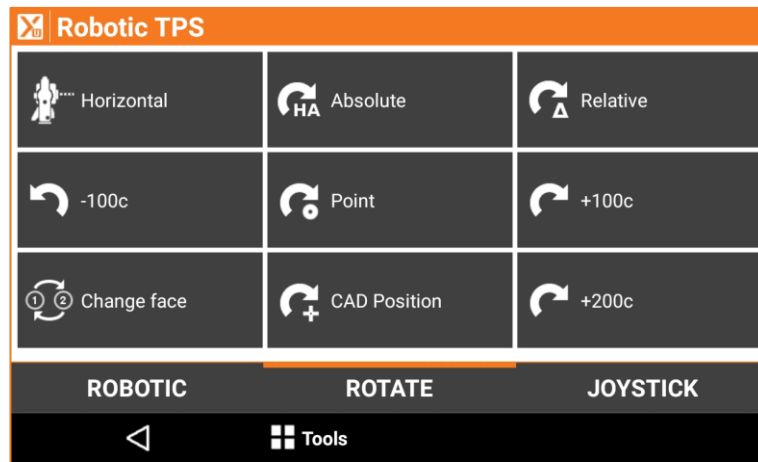

### Command

	Rotates the telescope horizontally
	Rotates the total station on a specific value of horizontal angle.
	Rotates the total station of a specified angular value.
	Rotates the total station of 100 gon/90 degrees toward left.
	Rotates the station toward a topographic point; it's requested to select the topographic point directly in the graphic window.
	Rotates the station of 100 gon/90 degrees toward right.
	Rotates the station on opposite face.
	Rotates the station toward a position; it's requested to select the topographic point directly in the graphic window.



Rotates the station of 200 gon/180 degrees.

### Joystick page

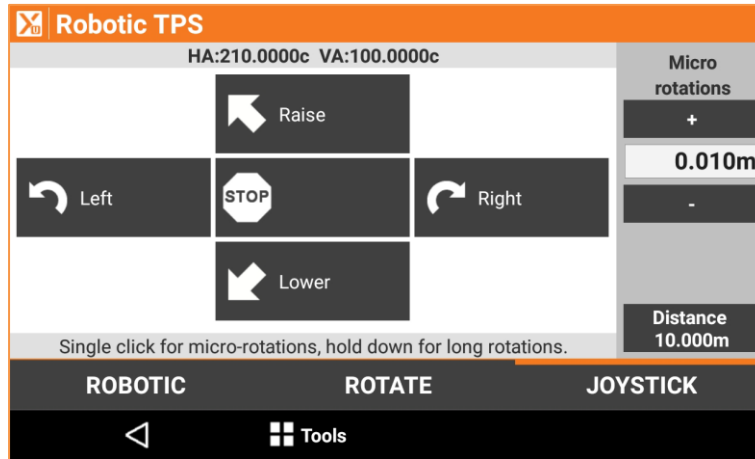

The buttons allow rotations in the following ways:

Action	Description
<b>Hold down</b>	The speed of rotation increases progressively and stops when it is released.
<b>Single Click</b>	It performs the microrotation.

Command	
	Starts rotation toward left. Clicking again you increase the speed.
	Starts rotation toward right. Clicking again you increase the speed.
	Starts rotation upward. Clicking again you increase the speed.
	Starts rotation downward. Clicking again you increase the speed.
	Stops rotation

<b>Microrotation</b>	Sets the accuracy of microrotation movements.
<b>Distance</b>	Displays the approximate distance for calculating the angle of the microrotations. If you hit the button, the distance from the target is measured.

### Definition of the research area of fixed targets



#### Parameters window

<b>Search window</b>	Activate to allow the research of prism only inside the defined window
<b>HA minimum</b>	Horizontal angle defining the left limit of research zone
<b>HA maximum</b>	Horizontal angle defining the right limit of research zone
<b>VA minimum</b>	Vertical angle defining the lower limit of research zone
<b>VA maximum</b>	Vertical angle defining the upper limit of research zone

#### Distance limits

<b>Distance range</b>	Activate to limit the research inside distance limits
<b>Distance minimum</b>	Minimum distance of research
<b>Distance maximum</b>	Maximum distance of research

#### AiM360 settings

<b>AiM360 mode</b>	Allows you to configure the automatic collimation according to the environmental situation: normal, low visibility or high reflectivity.
--------------------	--

Values of the search window can be inserted manually or it's possible to register them using the total station as pointing instrument.



It's asked to aim the lower left angle of the search window and then the upper right angle. It's possible to maintain the same dimension of search window but to specify a new position.

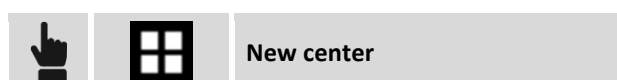

It's asked to specify the new center of the window. It's possible at the end to check which is the search window of the station.

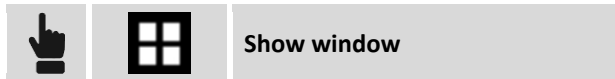

## Setting the environmental parameters (temperature, pressure, refraction / sphericity)



The window allows you to set the values of temperature, pressure and refraction that must be considered for the calculation of the distances measured.

## Search fixed targets

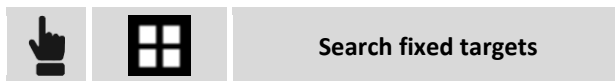

The command activates scanning for fixed targets at 360° to store their position to exclude them when the automatic prism search mode is active.

---

## Settings of type of target









This panel allows to edit the target to use for measures.



The three buttons in the upper part contain three prism types and it's possible to customize buttons specifying your three favorite prism types.

Command	
<b>3 upper buttons</b>	Selection of type of prism to use.

	Activates the mode of measure without prism.
	Activates the mode of measure Long Range with prism.
	Activates the mode of measure Tape.
	Visualizes the status of activation of laser pointer; clicking on panel you activate and deactivate the pointer.
	Opens the window that allows to set the constants to use both for measures with prism both without prism.
	Allows to edit the elevation of pole.

### Favorite prisms



Through this function it's possible to position in first three panels of the target selection window the three prisms most used. Click on buttons until when it appears the desired type of prism.

### Constants of targets

In this window it's possible to check the constants of different types of prism and specify the constant to use for the "user" type of prism.

Prism	
Type	Type of prism
Constant (mm)	Constant of prism. The value is editable only for the type of prism "user"
Constant absolute (mm)	Absolute constant of prism. The value can only be modified for the type of prism "User".

Moreover it's possible to set a constant to use in case of measures without prism or on tape.

Offsets	
Reflectorless (mm)	Constant to use in measures without prism.

Tape (mm)

Constant to use in measures on tape.

## Strategy of prism research



You can set a default action when the prism is lost

Field	Description
Search after lost	<p>Enables the automatic prism research after the prism has been lost from the total station. The automatic research modes are the following:</p> <ul style="list-style-type: none"><li>• <b>None:</b> no action is stated.</li><li>• <b>360° search:</b> starts a prism research at 360°.</li><li>• <b>Windows + 360:</b> a window search is started in the area where the prism was lost and then a 360°search.</li><li>• <b>Return to last position:</b> the station returns in the last direction where the prism was locked.</li><li>• <b>Use controller's GNSS:</b> use the GPS position of the controller to search for the prism.</li></ul>

### Use controller's GNSS

The prism can be searched based on the location of the controller provided by the internal GPS of the device. The search system will only start operating after at least 3 points have been measured; this allows the automatic definition of a search system, **SmartLocalization**, it is able to rotate the total station towards the direction in which the controller is located.

The search system continuously improves its accuracy and reliability for each every measured point. When the prism is "unlock" the unlocked lock icon (indicating prism unlock) is displayed in either of the following two ways:



The central positioning symbol is red if the system is not yet able to search for the prism with the GPS controller; vice versa, if the system is active the symbol is green.

The incorrect functioning of the system may depend on the quality of the GNSS position of the stored points.

It is possible to cancel the current calculation system and so return to the starting point where you have to measure at least 3 points in order to start using the system; you can reset the system by opening the control window of the robotic station, hit the **Tools** button and select the **Reset SmartLocalization data** option.







## TPS - Basic

### TPS

If current profile is related to a total station, from main menu it's possible in every moment to access to a window that allows to perform some simple measures without saving data.



	<p>Access to window that allows to perform measures with la total station without saving data.</p>
---	--





### Main commands

Command	
 <b>Robotic</b>	<p>Access to control panel of the robotic total station.</p>
 <b>Setup</b>	<p>Access to control panel of the mechanic total station.</p>
 <b>Set HA</b>	<p>Setting of horizontal angle of the station.</p>
 <b>Measure</b>	<p>Starting of measure. At the end of the measure the distances measured are reported in corresponding fields.</p>

In the upper part of the window a panel allows to access to other functions to control total station.



Command	
 <b>360° (23.1 mm)</b>	<p>Visualizes the current type of target; clicking on panel you access to window that allows to change the type of target and target height.</p>
	<p>Visualizes the status of locking of prism. Clicking on panel it's started the research of prism.</p>
	<p>Auto-collimation enabled.</p>

	<p>Visualizes the status of activation of laser pointer; clicking on panel you activate and deactivate the pointer.</p>
	<p>Visualizes the current mode of measure. They are available three status: Standard, Fast, Tracking (continuous measure).</p>
	<p>Sets the instrument height.</p>
	<p>Displays the E-Bubble.</p>

---

## TPS – Station setup

### TPS



Making the orientation of the station is a main step perform operations of surveying, stakeout and Auto Measuring with total station.



---

### Using previous setup

If previously it has been set an orientation the current orientation is proposed; current orientation can be accepted or it's possible to define a new orientation.

Command	
	Defines un new orientation.
	Hit <b>Accept</b> to confirm current orientation.

---

### Using the orientation of another job

The software saves the orientation of current job so that you can continue using it when you open or create a new job. When you open another job it's proposed to continue using the same orientation of the previous job.

---

### Loading the orientation stored in the station

With some total stations can happen to perform part of the work of survey with the X-PAD version working on board of the instrument and part with the version working of the external controller. If the station's orientation was performed with one of the two versions, the other version can continue to use the same orientation because the data of the latter were stored inside the station itself.

But it's necessary to proceed loading the orientation data by specifying that you want to use a new orientation, and then choosing the mode **Load internal TPS orientation** as explained below.

---

### Select point for station setup

The procedures for the station setup share the following options for selecting one or more points.

Systems	Description
CAD	Allows you to select the point to use as reference point from the CAD window.
Topographic points	Allows you to select the point to use as reference points from the topographic point table.

<b>Reference points</b>	Allows you to select the reference point from the reference points table.
<b>Add point</b>	Allows you to insert the reference point coordinates directly.

## Instrument height calculation mode

The procedures for the station setup share the following options for the instrument height calculation. You can access to the calculation option by hit > button of the field **Instrument height**.

### Calculate instrument height from slant height

You can calculate the instrument height by measuring the slant height on the TPS side marker. Instrument height will be calculated using reference width.

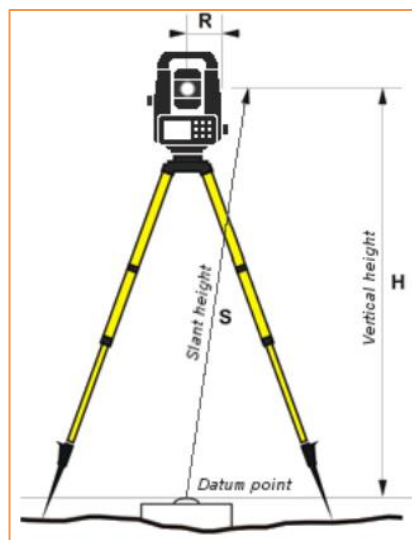

#### From slant height

<b>TPS model</b>	Shows the brand and the model of the active profile.
<b>TPS reference width (R)</b>	Sets the reference width.
<b>Slant height (S)</b>	Sets the slant height.
<b>Instrument height (H)</b>	Shows the calculated instrument height.

### Calculate instrument height from keyboard height

You can calculate the instrument height by measuring the slant height on the bottom border of the keyboard. Instrument height will be calculated using offset values.

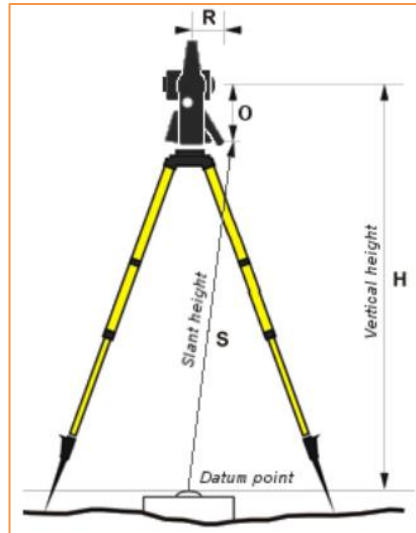

### From keyboard height

<b>TPS model</b>	Shows the brand and the model of the active profile.
<b>Keyboard horizontal offset (R)</b>	Sets the horizontal distance from the center of the telescope to the bottom border of the keyboard.
<b>Keyboard vertical offset (O)</b>	Sets the vertical distance from the bottom border of the keyboard to the center of the telescope.
<b>Slant height (S)</b>	Sets the slant height.
<b>Instrument height (H)</b>	Shows the instrument height.

### Calculate instrument height from reference point

You can calculate the height of instrument from a reference point that you will have to measure.

### From reference point

<b>Station elevation</b>	Show the elevation of the station.
<b>Reference value</b>	Set one of the following modes: <ul style="list-style-type: none"> <li>• <b>Reference point:</b> requires collimating a point of work or inserting the coordinates of a known point.</li> <li>• <b>Reference elevation:</b> requires collimating a point, that has a known elevation.</li> </ul>
<b>Point</b>	Sets the calculation reference point. Hit > to access to the options.
<b>Elevation</b>	Shows or sets the reference elevation according to the set reference value.
<b>Instrument height (H)</b>	Shows the instrument height.

### New orientation

When you open a job, the software allows to create a new orientation that can be of one of the following types:

Systems	Description
<b>Station position is known</b>	The station is already stored as a point in the current job file or the coordinates are known.
<b>Station position has to be calculated</b>	The station coordinates and the orientation needs to be calculated by measuring some reference points.
<b>No orientation</b>	It allows to define the station position but without any specific orientation.
<b>Load internal TPS orientation</b>	Some total stations can store the orientation made with other software. With this function the internal orientation of the total station is loaded and set as the current orientation. The orientation consists of the coordinates of the station and the instrumental height; it is assumed that the correction angle is equal to 0. With this function it's possible to share the orientation between different sessions of X-PAD running on the external controller or onboard. (Only for total stations GeoMax Zoom80 and Zoom90)

**When a job is opened you can also choose to use the last station setup used.**

## New orientation to known position

This kind of orientations requires that the station is already stored in the current job as point and its coordinate are known.

You can choose one of following the orientation mode:

Systems	Description
<b>Backsight to known point</b>	The station has been placed on a point of known coordinates and the orientation is determined through the measure of a reference point of known coordinates.
<b>Backsight by Azimuth</b>	The station has been placed on a point of known coordinates and the orientation is determined through the measure of a reference point of known azimuth.
<b>Orientation to multi points</b>	The station has been placed on a point of known coordinates and the orientation is determined through the measure of some reference points of known coordinates.

## Orientation to known point

This type of orientation requests to specify the position of the station and to specify the reference point; the reference point must still be present in the table of the topographic points or of the reference points.

Station	
<b>Station</b>	Name of the station; it's possible to select a point still existing.
<b>Instrument elevation</b>	Elevation of the total station from the ground. It is also possible to calculate the height of the instrument in different ways, as explained

	in the paragraph Instrument height calculation modes. To access the options hit >.
<b>Code</b>	Code to assign to the station point in case it's created a new point.

Position	
<b>ENZ</b>	Coordinates of the station; if it was selected a point of the archive it's not possible editing values.

Hit **Next** to proceed with procedure.

Point of orientation	
<b>Point</b>	Specify the reference point to measure to calculate the orientation of the station
<b>Azimuth</b>	It's calculated the azimuth between the position of the station and the reference point
<b>Circle</b>	Allows to define how to set the horizontal angle of the station: <ul style="list-style-type: none"> <li>• <b>Current value:</b> the angle of the station is not modified</li> <li>• <b>Zero:</b> the angle of the station is reset on reference point</li> <li>• <b>Azimuth:</b> the angle of the station is set on azimuth value</li> </ul>

Hit **Measure** to proceed with measure of reference point. Aim the point of orientation and proceed with the measure. It's visualized a report with data calculated and with the differences of angle and distance. Hit **Accept orientation** to confirm set data and complete procedure.

### Orientation by Azimuth

This type of orientation requests to specify the position of the station and to specify the reference point for which is not known the position but the azimuth.

Station	
<b>Station</b>	Name of the station; it's possible to select a point still existing.
<b>Instrument elevation</b>	Elevation of the total station from the ground. It is also possible to calculate the height of the instrument in different ways, as explained in the paragraph Instrument height calculation modes. To access the options hit >.
<b>Code</b>	Code to assign to the station point in case it's created a new point.

Position	
<b>ENZ</b>	Coordinates of the station; if it was selected a point of the archive it's not possible editing values.

Hit **Next** to proceed with procedure.

Point of orientation	
----------------------	--

<b>Azimuth</b>	It's calculated the azimuth between the position of the station and the reference point
<b>Circle</b>	Allows to define how to set the horizontal angle of the station: <ul style="list-style-type: none"> <li>• <b>Current value</b>: the angle of the station is not modified</li> <li>• <b>Zero</b>: the angle of the station is reset on reference point</li> <li>• <b>Azimuth</b>: the angle of the station is set on azimuth value</li> </ul>

Hit **Measure** to proceed with measure of reference point. Aim the point of orientation and proceed with the measure. It's visualized a report with data calculated and with the differences of angle and distance. Hit **Accept orientation** to confirm set data and complete procedure.



### Orientation to multi points

This type of orientation of the station calculates the orientation, of known coordinates, on the basis of measurements at a number of points of orientation for which the position is known.

Station	
<b>Station</b>	Station name; it's possible to select an existing point.
<b>Instrument height</b>	Height of total station from the ground. It is also possible to calculate the height of the instrument in different ways, as explained in the paragraph Instrument height calculation modes. To access the options hit >.
<b>Code</b>	Code to be assigned to the station point.

Click **Next** to continue the procedure. The procedure asks you to specify the first reference point and perform the corresponding measure; it's possible to enter the reference name, or select it from the points table, from the table of the reference points or from the graphic window. Aim at the reference point selected and press **Measure**.

It's then asked to perform the same operation for the second reference point. The two measured points are reported in a table showing the differences calculated at each point and the total standard deviation on the orientation calculation.

Command	
	Enables and disables the use of the measure for the orientation calculation of the station.
	Allows you to add the measure of other reference points to improve the quality of the calculation and for more control of the data.
	Confirmation of the calculated data. You receive a report with the calculated data

Press **Accept orientation** to confirm the input and complete the process

### New orientation with a position has to be calculated

This kind of orientations determines the coordinate and the orientation of the station by measuring some reference points.

You can choose one of following the orientation mode:



Systems	Description
<b>Free station</b>	The position and the orientation of the station are determined by measuring of at least two reference points with known coordinates.
<b>Auto free station</b>	Performs an automatic search and measurement of all the targets around the station. The position and orientation of the station are determined by comparing the measurements with the reference points which have to be present in the job. This calculation mode is only active when using a robotic station.
<b>Reference axis</b>	The position and orientation of the station are determined by measurements of two reference points. The two points set the origin and direction of the X axis.
<b>2 reference axis</b>	The position and orientation of the station are determined by measurements of four reference points. The points set two axes which, intersecting each other, determine the position of the station.
<b>Batter boards</b>	The position and orientation of the station are determined by measurements of three reference lines which, intersecting each other, determine the two position corresponding to two reference point of the project.
<b>Free station 3D</b>	The position and the orientation of the station are determined by measuring of at least three reference points with known coordinates. The software will perform a 3D spatial transformation (helmert 3D).

### Free station

This type of orientation calculates the position of the station basing on measures to at least two points for which is known the position.

Station	
<b>Station</b>	Name of the station; it's necessary to specify a new point.
<b>Instrument height</b>	Height of the total station from the ground. It is also possible to calculate the height of the instrument in different ways, as explained in the paragraph Instrument height calculation modes. To access the options hit >.
<b>Code</b>	Code to assign to the station point in case it's created a new point.

Hit **Next** to proceed with procedure. The procedure asks to specify the first reference point and to perform corresponding measuring; it's possible to type the name of reference point or to select it from table of points, from table of reference points or from graphic window. Aim the reference point selected and hit **Measure**.

If you have the X-Pole module and the pole in X-Pole configuration, it's possible to use the position provided by the GPS receiver as a known position in which to perform then the measure with the total station; in this case, when asked to indicate the point of known coordinates it is possible to choose item Measure (with GPS), proceed to measure point with GPS and proceed to measure the same with the total station.

**Select point**

 CAD

---

 Topographic Points

---

 Reference Points

---

 Add point

---

**CANCEL**



It's then asked to perform the same operation for the second reference point. The two points measured are reported in a table with deviations calculated in correspondence of every point and the total standard deviation standard on calculation of the position of the station.





 **Station setup**

**Measurements to reference points**

<b>H</b> <b>V</b> S2	$\Delta H$ : 0.000m <input checked="" type="checkbox"/> $\Delta V$ : 0.000m <input type="checkbox"/>
<b>H</b> <b>V</b> S3	$\Delta H$ : 0.001m <input checked="" type="checkbox"/> $\Delta V$ : 0.000m <input type="checkbox"/>
<b>H</b> <b>V</b> S4	$\Delta H$ : 0.001m <input checked="" type="checkbox"/> $\Delta V$ : 0.000m <input type="checkbox"/>

**Calculation executed**  
 Std.Dev. E 0.0005m N 0.0003m Z 0.0001m

 Add point
 Accept setup

Command	
	Activates and deactivates using of the measure for calculation of the coordinates of the station.
	Activates and deactivates using of the measure for calculation of the elevation of the station
	Allows you to change the types of differences displayed by tap.
	Allows to add the measure of other reference points to improve the quality of calculation and for a better check of data.
	Confirmation of data calculated. It's visualized a report with calculated data.

Hit **Accept orientation** to confirm set data and complete procedure.

### Open Free station

The procedure of station setup with free station mode can be completed at later time, during the survey operation, although it is good practice, with X-PAD it is not mandatory to complete this procedure before starting the point survey.

The possibility to leave “open” the free station allows to measure the control points when in their proximity, without necessarily forcing the operator to measure all the control points which could also be very far from each other.

The free station setup requires the measurement of at least two control points; at this step the software asks if you want to proceed with the measurement of control points; to this request you can answer “**Not now**” by postponing the measurement of the control points to a later step.

If you start the free station without measuring any control points, the station will assume arbitrary local coordinates and no orientation; if only one control point has been measured, the station will assume local coordinates with respect to the control point but without any orientation.

If you use two or more control points the station can already have a correct position and orientation. If you want add new control points to the free station which has been leave “open”, you have to go back to the command of the **Survey points** of station setup procedure , by clicking on the station data panel. When a new control point is added, the free station is recalculated and the position and orientation of the station is recalculated; consequently, the position of all the points previously measured by the station is also recalculated.

### Free station 3D

The orientation mode “Free station 3D” defines the position and orientation of station based on measurements of 3 or more reference point. The calculation is based on a 3D transformation instead of a separate coordinate and elevation calculation.

The procedure is like that of the **Free Station** paragraph.

### Auto Free station

The orientation mode “Auto Free station” performs an automatic research and measurements of all targets around the station. The measurements are compared with the coordinates of the reference points, which must have been inserted into the job previously, in this way the software calculates the position and orientation of the station. This calculation mode is only active when using a robotic station.

### Reference axis

This type of orientation calculates the origin and position of the station based on the measurement of two reference points. The two points set the direction of the X axis.

Station setup	
<b>Station</b>	Name of the station; it’s necessary to specify a new point.
<b>Instrument height</b>	Height of the total station from the ground. It is also possible to calculate the height of the instrument in different ways, as explained in the paragraph Instrument height calculation modes. To access the options hit >.
<b>Code</b>	Code to assign to the station point in case it’s created a new point.

Hit **Next** button. Enter the origin coordinates of reference axis, then hit **Select** to choose a stored point or hit **Measure** to perform a measure a new reference point.

The procedure requires to collimate the origin point of the axis (REFAXIS-ORIGIN) and hit **Measure**; then collimate a point that sets the direction of the reference axis (X axis) (REFAXIS-DIRECTION) and hit **Measure**.

The procedure shows the calculated axis length.

The setup of reference axis has been completed; hit **Accept setup** to end the procedure.

## 2 reference axes

This type of orientation allows to calculate the origin and position of the station through the measurement of two reference lines existing in the work site and through the coupling with two corresponding lines stored in the data of the job.

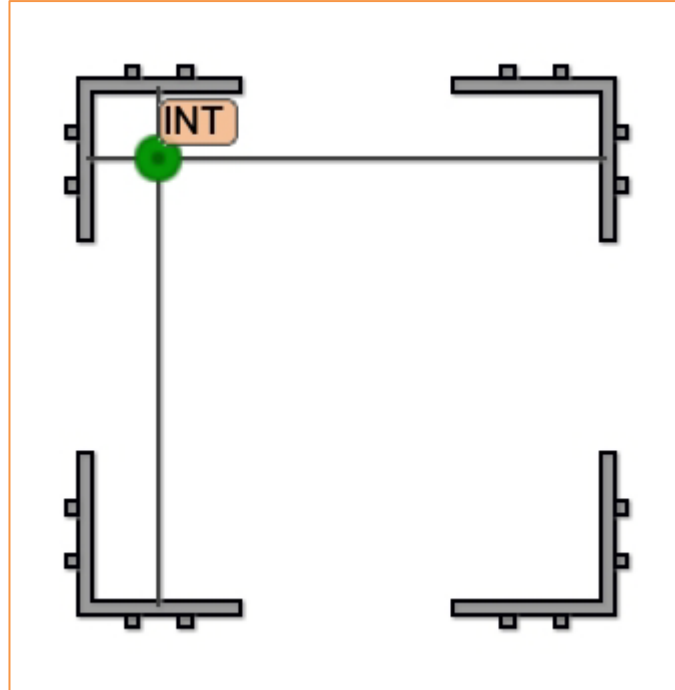

The steps to follow are as follows:

Step	Description
1	Hit <b>Measure</b> to perform the measurement of the two points, which set the first of the two reference axes.
2	Hit <b>Measure</b> to pass to the measurement of the two reference points which set the second of the two reference axes.
3	Hit <b>Select</b> to choose from the graphic window the first reference line that corresponds to the first measured reference axis.
4	From the graphic window, select the second reference line that corresponds to the second measured reference axis.
5	Two possible solutions of the station position are proposed; Click on the correct solution and hit <b>Save</b> .
6	The procedure ends with storing the position and orientation of the station.

## Batter boards

This type of orientation allows to calculate the origin and position of the station if the two reference points are not clearly identifiable at the site, but their position is determined by the intersection of three reference existing lines:

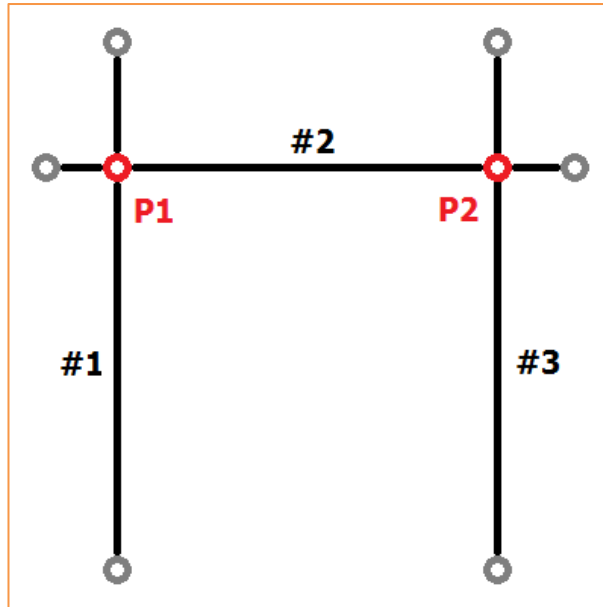

The two points P1, P2 not materialized on the site, correspond two points of reference present in the job data.

The procedure begins by requiring the measurement of the two points constituting the first reference line, and then continues by measuring the second and third reference lines. The preview window displays the measured lines.

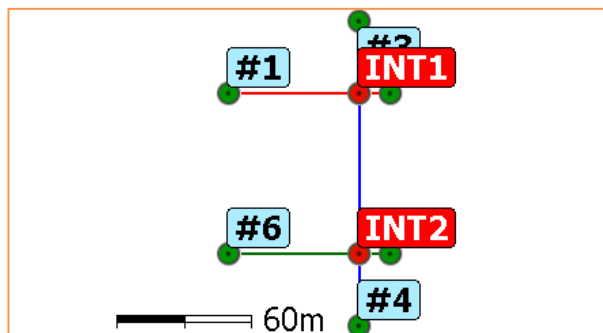

Hit **Select** to choose the point of the job that corresponds to **INT1**; hit **Select** again to set the point of the job that corresponds to **INT2**.

## No orientation

In this mode station is not oriented but only the position is established.

Station	
Station	Name of the station; it's possible to select a point still existing.
Instrument height	Height of the total station from the ground. It is also possible to calculate the height of the instrument in different ways, as explained in the paragraph Instrument height calculation modes. To access the options hit >.
Code	Code to assign to the station point in case it's created a new point.

Position	
ENZ	Coordinates of the station; if it was selected a point of the archive it's not possible editing values.

Hit **Accept orientation** to confirm set data and complete procedure.

## Check orientation

You can check if the orientation of the station is still valid or if you need to perform the orientation again. From the window of **Station setup** hit **Check orientation** and collimate the orientation point. The software will show a report with the difference, then hit **Continue**. The software then asks whether this measure should be used as a new backsight orientation for subsequent measurements.

## Changing the height of the station

You can change the instrument height from the window of **Station setup** hit **Set instrument height**. This command allows you to change the instrument height of all station measurements and recalculate the elevations of measured points.

## Reset the station elevation

It is possible reset the station elevation, from the window **Station setup** hit **Reset Z** button in the part of window which shows the coordinates of station.

## Setting of elevation of the station from reference point

You can calculate the elevation of a station by measuring one or more reference points. From the window **Station setup** hit **From point** button in the part of window which shows the coordinates of station.

### Set elevation from a single point

The command allows you to calculate the station elevation by measuring a reference point. The procedure requires to select the reference value to perform the calculation and take the measure.

Elevation from reference	
Reference value	Allows to set the calculation from: <ul style="list-style-type: none"> <li>Point</li> <li>Elevation</li> </ul>
Point	If the set reference value set is Point allows to select a point of job to use as reference for calculation of the elevation of the station.
Elevation	If the set reference value set is Elevation allows to insert the elevation of the reference point.

### Set elevation from multi points

The command allows you to calculate the station elevation by measuring different reference points.

The procedure requires to set the reference point, collimate it and measure it.  
You can add reference points for calculation by hitting **Add**.

## TPS - Survey of points

### TPS



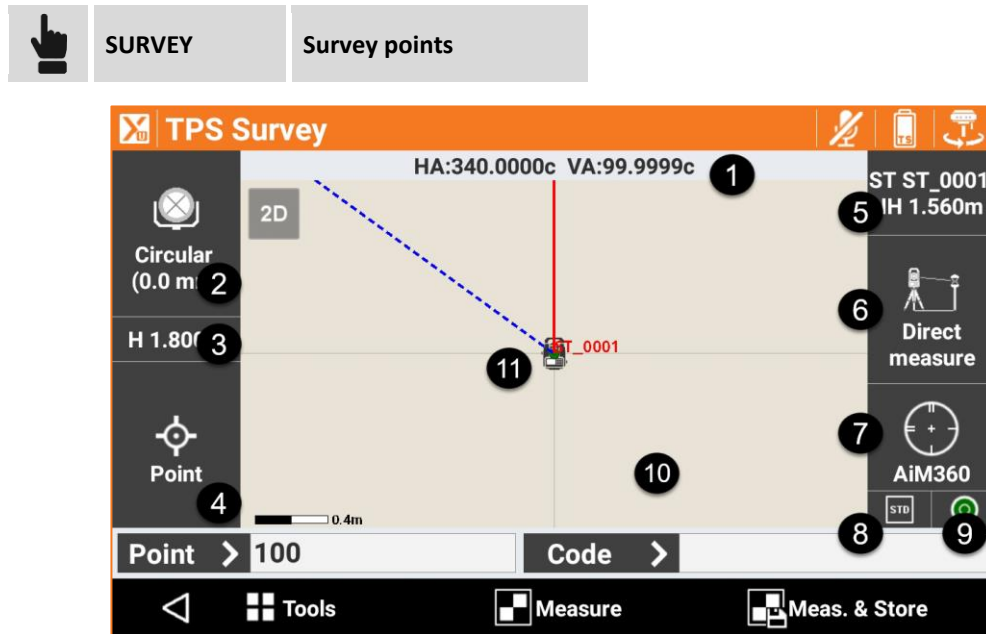





This chapter illustrates commands allowing measuring points with the total station, mechanic and robotic; they are analyzed the different operative modes.

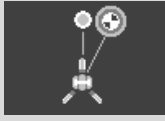

The window presents some panels on external borders reporting different information on settings of the station and allowing to manage the different functions available.

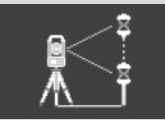
Panel	Title	Description
1	Angles	The panel reports the current angles of the total station.
2	Current target	Visualizes the type of current target; clicking on panel it's possible to edit the type of target. See paragraph <b>Setting of the type of target</b> .
3	Elevation of the target	Visualizes the current elevation of the target; clicking on panel it's possible to edit the elevation.
4	Smart Drawing – Drawing during survey	The panel reports the current status of the function Smart Drawing; clicking on panel it's possible to choose the tool of drawing or the operation to perform. See paragraph <b>Smart Drawing</b> .
5	Current station	Name and elevation of the current station; clicking on panel you access to the window that allows to change the orientation of the station. See chapter <b>Station setup</b> .
6	Measuring mode	Visualizes mode of measure. They are available the following modes of measure:  <b>Direct measure:</b> measure directly to point.



			<b>Point polygonal:</b> specifies that the next point measured is a point of polygonal. The points of polygonal are saved to allow a rapid change of station.
			<b>Offset HA:</b> allows to perform a measure to an object for which it's not possible to position the prism in the point to measure.
			<b>Offset VA:</b> allows to perform a measure to a point not accessible by the prism but finding over or under it.
			<b>Offset Distance:</b> allows to perform a measure to a point not accessible by the prism but finding to a certain distance referring to it along the direction station-prism.
			<b>F1/F2:</b> measures the point with the two faces and performs the average of the measures.
			<b>Only HA:</b> measure only the angles of the point.
			<b>Multi target:</b> measure using multi target pole.
7	<b>Status of locking of the prism (robotic station)</b>		Status of locking of the prism. Clicking on button it's opened the window of control of the robotic total station.
			
			It indicates the status of automatic prism collimation.
7	<b>Setup station (mechanic station)</b>	Clicking on panel it appears the window that allows to manage the parameters of functioning of the mechanic total station.	
8	<b>Mode of measure</b>	Visualizes the current mode of measure. They are available three status: Standard, Fast, Tracking (continuous measure)	
9	<b>Status of the bubble</b>	Visualizes the status of the bubble; the symbol in red indicates that the instrument is out of bubble.	
10	<b>Graphic area</b>	Graphic view with visualization of the survey and of the drawing. Clicking twice in the graphic part part you access to the main CAD window.	
11	<b>Station position</b>	Current position of the station. The red line represents the direction of orientation, instead the blue line represents the current direction of the total station.	

The requested data for recording of the point are the following:

Field	
Point	Name of next point to measure
Code	Code to assign to next point to measure

In the lower part a toolbar allows to access to a menu of advanced functions and to commands for measuring points.



## TPS display mode

Refer to chapter **Survey of point - GPS and TPS common functions** paragraph **TPS and GPS display mode**.

### Automatic updating of the view



If remote control of the instrument is enabled the use of the option  shows the direction from the pole to the station.

## Rapid measuring of points







Command	
 <b>Measure-Save</b>	Measuring of current position and direct saving of the point.
 <b>Stop</b>	Allows to stop measuring.

**Note.** If to the code of the point has been associated a GIS feature it appears a window visualizing the attributes of the GIS feature that have to be filled in by the operator.

## Measuring of points

Command	
 <b>Measure</b>	Measuring of target. At completion of the measure it's possible to decide if proceeding to record the point; in this phase it's possible to edit the angle measured aiming the point on which it wasn't possible to position the prism.
 <b>Stop</b>	Allows to stop measuring.
	Saves the measure and proceeds with visualization of data of the point.

Page Data	
Point	Name of next point to store
Antenna elevation	Elevation of the target
Code	Code associated to the point. See paragraph <b>Survey codes assignment</b> and <b>Quick codes</b> in chapter dedicated to <b>Survey codes</b> .
Description	Extended description associated to the point

Sketch page	
	Deletes sketch and photo.
	Restores original content.
	Adds a label with the main point information; the label can be moved to any position.
	Adds a label with free text; the label can be moved to any position.
	Adds an arrow symbol; the arrow can be moved and rotated.
	Active the free drawing mode.
	Starts application allowing to shoot a photo and save it.

Results page
General information about point to register.

**Note.** If to the code of the point has been associated a GIS feature it appears a window visualizing the attributes of the GIS feature that have to be filled in by the operator.

## Measuring traverse points

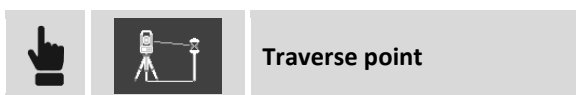

With this option activated, the next point measured will be saved as a traverse point; It's useful so activating this option before measuring points that will be the next stations.

At the moment to perform the change of station it's possible to click on panel that reports data of the current station (name and elevation); before passing to the window of orientation of the station it's requested if you desire to occupy one of the traverse points measured previously. Select the traverse point that you are occupying: the software passes directly to procedure of orientation of the station on known point setting the traverse point as station and the previous station as point of orientation.

**Note.** After the traverse point has been measured, the option **Traverse point** is deactivated and so it's necessary to repeat the setting for the next point of polygonal.

---

## Measuring of points by offset horizontal angle



This mode of measure allows to measure the position of an object when it's not possible to position the prism exactly where requested. The prism must be positioned at the side of the object to measure and it's then measured normally; afterwards It's asked to aim the center of the object. It's recorded a measure having the angles of the center of the object and the distance measured on prism.

---

## Measuring of points by offset vertical angle



This mode of measure allows to measure the position of an object that is on the vertical of position of the prism but it's not reachable by the prism itself. The prism must be positioned on the vertical of the object to measure it's then measured normally; afterwards It's asked to aim the center of the object. It's recorded a measure having the vertical angle of the center of the object and the distance measured on prism.

---

## Measuring of points by offset in distance



This mode allows to perform a measure to a point not reachable by the prism but finding itself to a certain distance referring to it along the direction station-prism.  
Position the prism in a visible and measurable position by the total station and then proceed with the measure; before recording the measure they are requested three offset values:

### Measure by offset

<b>Forward/backward</b>	Distance along direction station – prism
<b>Right/left</b>	Lateral offset referring to direction station – prism
<b>Up/down</b>	Slope difference referring to position of the prism

**Note.** Directions **Forward/backward**, **Right/left** have to be considered opposite if you are working in Remote mode (controller on the pole).

---

## Measuring of points on face 1 and face 2



This mode of measure allows to measure the same point before with face 1 and then with face 2. The measure recorded is the result of the average of the single measures. If the values of the two measures are different of more than the preset tolerance, it's visualized a message of warning.

## Measuring of points only with angle

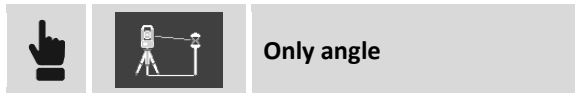

This mode records a measure with only the values of the horizontal and vertical angle. Since it's missing the distance the coordinates of the point can't be calculated and the point can't be visualized.

## Multi target pole

The multi target pole is a particular pole for measure in which there are two or multiple targets (prisms, tape, ...) and is used to detect those complex situations where the point to measure is not visible and it's not possible to keep the pole vertical. The measure of at least two targets allows to calculate the three-dimensional position of the point.



Press **Measure** button to access the window of pole measure with multiple targets.



## Setting the pole parameters



Field	Description
Lenght	Total pole length
Num. target	Number of targets present
Distance between target	Distance between targets
Calculation tolerance	Tolerance to use to accept the calculation

## Measure of the targets

Select the number of the target to measure, aim and press **Measure**. Repeat for the second target. With two measures it appears a table with the results of the calculation and the errors of each measure.

Button	Description
	It adds the measure of a further target
	Saves the measures and stores the point

# TPS - STAKEOUT

## TPS

Stakeout procedures allow to provide to the operator the information in graphic, numeric and vocal format, to reach a point, an element or in general a particular position. A wide range of options and operative modes are available.

Before proceeding with stakeout it's necessary to define with precision the orientation of the station in order to guarantee the correct matching between surveyed positions and positions to stakeout.

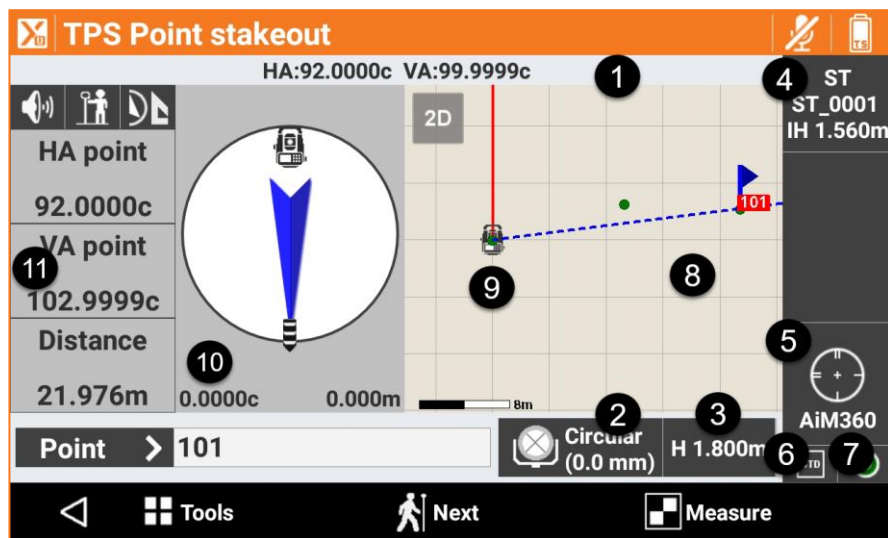

### Stakeout information

Information provided by the software during stakeout of a position are quite common and similar in all modes; whether you are doing stakeout of a point, of an element or of a position by offset, the software provides indications to reach position to stakeout using a common scheme.

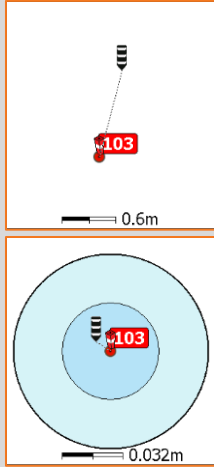

The stakeout window presents some panels on external borders reporting different information concerning receiver status and allowing to manage the different available functions.

Panel	Title	Description
1	Angles	The panel reports the current horizontal angles of the total station.
2	Current target	Visualizes the type of current target; clicking on panel it's possible to edit the type of target. See paragraph <b>Setting of type of target</b> .
3	Elevation of target	Visualizes the current elevation of the target; clicking on panel it's possible to edit the elevation.
4	Current station	Name and elevation of current station.
5	Status of locking of the prism (robotic station)	 Status of locking of the prism. Clicking on button it's opened the control window of the robotic total station.

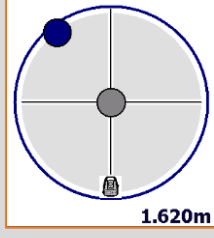
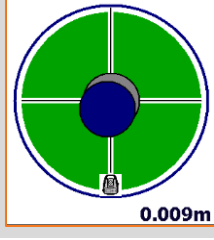
5	<b>Setting station (mechanic station)</b>	Clicking on panel it appears the window that allows to manage parameters of functioning of the mechanic total station.	
6	<b>Mode of measure</b>	Visualizes the current mode of measure. They are available three status: Standard, Fast, Tracking (continuous measure)	
7	<b>Status of the bubble</b>	Visualizes the status of the bubble; the red symbol indicates that the instrument is out of the bubble.	
8	<b>Graphic area</b>	Graphic view with visualization of survey and of the drawing.	
			
9	<b>Station position</b>	Current position of station. The blue line represents the current direction of the total station.	
10			This panel shows the current direction of the total station referring to direction of the stakeout point. Rotate the station toward the stakeout position. In the lower part of the panel it's reported the distance in meters, and the difference of angle, between the current direction and the stakeout point.
10			When it's performed a measure the panel shows the position of the target referring to the station and referring to the stakeout position In the lower part of the panel it's reported the distance between the target and the stakeout position.
10			When you are near the position to reach, inside tolerance values, the circle becomes green.

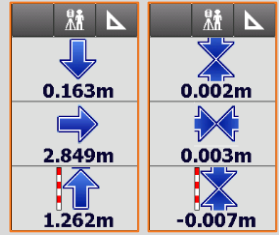
11		<p>Numeric indications to reach position. Indications are referred to the station toward the target or to the target toward the station.</p> <p>First value is referred to distance <b>Forward-Backward</b>.</p> <p>Second value is referred to distance <b>Right-Left</b>.</p> <p>Third value specifies the <b>elevation</b> difference.</p>
----	---	---





**Note.** If it is activated the mode **Remote control**, and so the controller is on the pole, previous data are visualized in the opposite side, considering that the operator is looking at the station.

### Stakeout tolerance

Reaching of position happens when the distance between current position and the position to reach is less or the same as **Stakeout Tolerance**. Stakeout tolerance is set in the **Stakeout parameters**. From every stakeout procedure it's possible to enter in the stakeout parameters and to check tolerance value.

### Information referring to Target, to total station, to North or to a reference point



The information provided in the panel on the right are referred to:

	<b>Position of the target:</b> from position of the target look with the controller toward the total station
	<b>Total station:</b> from total station look toward the target
	<b>North:</b> look with the controller toward north
	<b>Reference point:</b> look with the controller toward the reference point

Click on button to change reference.

### Graphic and analytic view

To move from analytic to graphic view use buttons .

Command	
	Enables display of analytical mode only, which indicates the distance from the point.
	Enables the graphic window display.
	Enables the mixed display that shows distance from the point and the graphical window.

### Vocal information

The software guides the user with vocal information allowing, most of all when you are far from the point, to arrive near the point without having to look always on the controller.

A tone tells when is reached, inside preset tolerance limits, the desired position.

To enable and disable vocal information use buttons .



## Common operations in stakeout

All stakeout operations have common operations and functions that are reported below.

### Measuring the point

Command	
 Measure	Starts measuring of stakeout point.
 Accept	After having reached the stakeout position it's possible to record the point.

Command proceeds showing some stakeout data: Hit **Next** to proceed and complete recording. Stakeout data are saved and it's possible to read and export them from window **Stakeout report**. The next point to stakeout is automatically proposed by the software.

**Note.** For further information on accuracy check see the paragraph **Accuracy check and Stakeout Parameters** in this chapter.

### Stakeout parameters

		Survey setup	Stakeout
---	---	--------------	----------

Field	Description
<b>Distance tolerance</b>	Maximum horizontal distance between current position and position to reach to consider being on stakeout position; if the distance between current position and position to reach is lower or equal to tolerance, the software reports the reaching of stakeout position.
<b>Elevation tolerance</b>	Maximum acceptable difference between current elevation and stakeout elevation; if the elevation difference is lower or equal to tolerance the software reports the reaching of the position in elevation.

### Miscellaneous

Field	Description
<b>Vocal info</b>	Activates the vocal information during the stakeout operations.
<b>Confirm before saving</b>	Allows checking the stakeout position before proceeding to saving new point on position to stakeout. Disabling this option the stakeout point is saved without any further request.
<b>Tacking mode</b>	When this option is activated the tracking mode is always set with the continuous surveying mode.
<b>Reference TPS</b>	Defines reference referring to which the information to reach the stakeout position with the total station are provided. References can be: <ul style="list-style-type: none"> <li>- <b>Target:</b> information are provided considering the operator on the target looking toward the total station.</li> <li>- <b>Total station:</b> information are provided considering the operator on the TPS.</li> </ul>

	- <b>North:</b> : information are provided referring to North.
<b>Turn toward point</b>	When this option is activated the motorized total station turns automatically toward the stakeout point when it's selected.
<b>Stakeout display mode</b>	Sets the default display mode of the survey graphics window performed with total station. <b>2D (TPS direction):</b> displays items of drawing and surveying in 2D oriented mode according to the direction of the total station. <b>2D (north):</b> displays items of drawing and surveying in 2D oriented mode according to the North. <b>3D (TPS direction):</b> displays items of drawing and surveying in 3D oriented mode according to the direction of the TPS. The program shows the direction based on the position of the controller, which can be behind the TPS or behind the pole.

Hit **Accept** to save the modifications.

### TPS display mode

Refer to chapter **Survey of point - GPS and TPS common functions** paragraph **TPS and GPS display mode**.

### Turn toward point



This command starts the automatic rotation of the motorized station toward the direction where it is the point to stake.

### Insertion of a Note

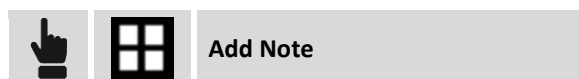

During stakeout it's possible to add in the field book some notes and sketches that can be helpful when working on acquired data in the office.

### Point & measurement

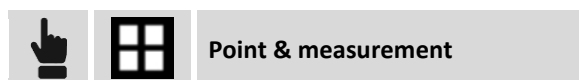

During tracking operations, you can access point and measure management. For further information refer to chapter **Points, measures, survey codes and GIS features managing**.

### Show up/down target buttons



Allows to display two buttons at the bottom of the screen. Buttons are useful when using reflectorless measurement mode to find the position of the dots on the floor, but the theoretical position is covered with material. The buttons allow to move up and down the height of the target in order to determine the correct position of the point above the material; in this case the stacking out concerns the X, Y coordinates and not the elevation. A single click changes the height of the target by 1cm, a longer pressure changes the height by 10 cm; at each change in height of the target the vertical angle of the station is corrected accordingly.

## Stakeout of points

The Stakeout of points procedure allows the operator to define, in different modes, the position to reach and to be guided by the software on the position to reach in the fastest way possible.



Select mode	
<b>Point from CAD</b>	Select the point to stake directly from graphic window
<b>Point from table</b>	Select the point to stake from list of points
<b>Automatic by position</b>	Automatically select the nearest point to stake out according to position of the receiver .
<b>List of points</b>	Allows to create a list of topographic points to stake.
<b>Coordinates</b>	Manual definition of coordinates East, North and Elevation to stake. Coordinates can be selected from the CAD drawing.



## Stakeout of a list of points



It appears a window in which the button **Tools** allows to execute main operations.

Tools	
<b>Load all points</b>	Loads in the list all the topographic points present in the job.
<b>Select from table</b>	Allows to select from the table topographic points to add to the list.
<b>Select from CAD</b>	Allows to select from the graphic window topographic points to add to the list.
<b>Delete points</b>	Allows to select from the list the points to delete.
<b>Clear list</b>	Deletes content of the list.
<b>Load list from file</b>	Allows to load the list from a file of points previously created.
<b>Save list to file</b>	Saves the list of points on an external file to be loaded later.
<b>Delete list of points</b>	Deletes content of the list.
<b>Load all points</b>	Loads in the list all the topographic points present in the job.

Selecting a point from the list you can change its position inside the list or delete it from the list. The icon aside every point identifies if the point has been still staked.

Icon	
	Point of the list that has been still staked.
	Point of the list not yet staked.

### Stakeout of coordinates ENZ

Coordinates ENZ	
E/N/Z	Coordinates of the position to stake.
	Hit <b>Select</b> to define coordinates by selecting on the drawing of the graphic window.

### Stakeout procedure

After having defined position to stake it appears the main stakeout window.

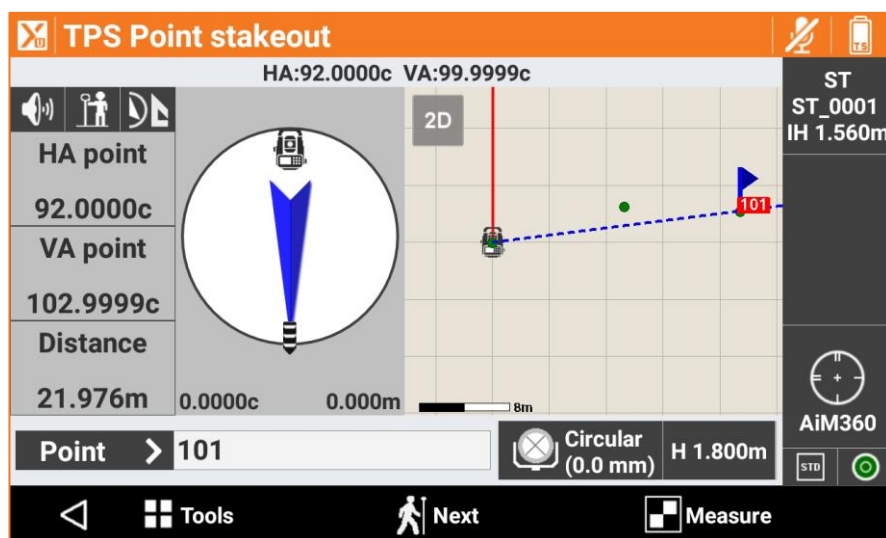

### Stakeout of next point



It's possible to choose the next point to stake in following modes:

Next point to stake	
Next	It is selected the next point, according to recording order, to current point.
Previous	It is selected the previous point, according to recording order, to current point.

<b>Nearest</b>	It is selected the nearest point, which hasn't been yet staked, to current point.
<b>From CAD</b>	Manual selection of the point to stake in the graphic window. Tap the point and hit <b>Stakeout</b> .
<b>From Table</b>	Manual selection of the point to stake from the table.

## Stakeout of lines/arcs/objects

This procedure allows to position with precision along geometric elements as lines, arcs or drawing elements.

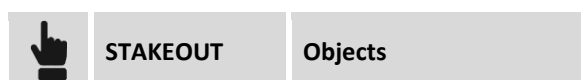

It's possible to define the element to stake in different modes.

Reference	
<b>Type</b>	Allows to choose mode to define element to stake. Possible options are: <b>Line (2 points)</b> : line defined by two reference topographic points. <b>Arc (3 points)</b> : arc defined by three reference topographic points. <b>Arc (2 points +R)</b> : arc defined by two topographic points and by the radius. <b>Drawing object</b> : drawing element (line, polyline, arc, circle) to select in the graphic window.

### Stakeout of line by 2 points

Line by 2 points	
<b>Point 1</b>	First point of the reference line
<b>Point 2</b>	Second point of the reference line
<b>Invert</b>	Inverts the direction of the line.
<b>Info</b>	Shows the information of the object.

### Stakeout of arc by 3 points

Arc by 3 points	
<b>Point 1</b>	First point of the reference arc
<b>Point 2</b>	Second point of the reference arc
<b>Point 3</b>	Third point of the reference arc
<b>Invert</b>	Inverts the direction of the arc.
<b>Info</b>	Shows the information of the object.

## Stakeout of arc by 2 points and radius

Arc by 2 points and radius	
Point 1	Starting point of the reference arc
Point 2	Ending point of the reference arc
Radius	Radius of the reference arc
Clockwise arc	Direction of the reference arc
Invert	Inverts the direction of the arc.
Info	Shows the information of the object.

## Stakeout of CAD element

It's requested to select from the graphic window the drawing element to stake.

## Offset

After defining the stakeout element it's possible to specify an additional offset, to the right or to the left.

Offset	
Offset	Distance to observe referring to reference element

## Multiplier

The command activates the stakeout of multiple offsets according to the set value of reference offset. When the option is active, the software shows the distance from the nearest offset and displays the multiplication factor of the offset distance.

## Stakeout procedure

After having defined the element to stake it appears the main stakeout window.

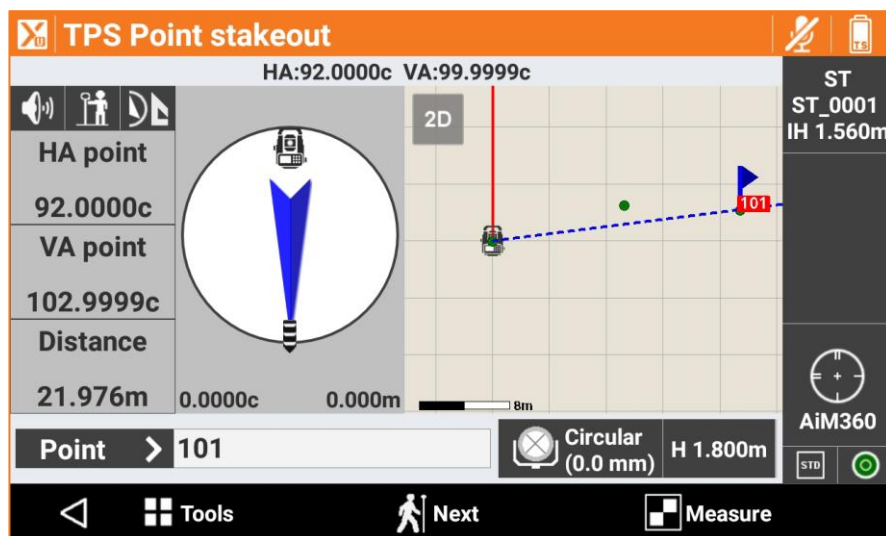

In the lower part is reported the station distance and the current distance referring to the element to stake.

## Information of stakeout

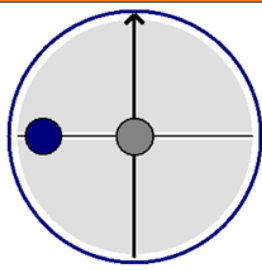
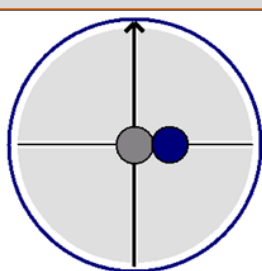
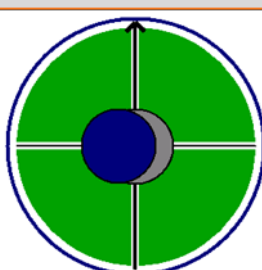
 <p><b>LEFT</b>      <b>-0.685m</b></p>	<p>Current position is on the left referring to the reference element.</p>
 <p><b>RIGHT</b>      <b>2.406m</b></p>	<p>Current position is on the right referring to the reference element.</p>
 <p><b>-0.012m</b></p>	<p>Current position is on the reference element.</p>

## Stakeout of station & offset

This procedure allows to execute stakeout of a position calculated referring to a station distance and to an offset distance on a reference element.



It's possible to define the reference element in different modes.

Type	
<p>Type</p>	<p>Allows to choose mode to define element to stake. Possible options are:  <b>Line (2 points)</b>: line defined by two reference topographic points.  <b>Arc (3 points)</b>: arc defined by three reference topographic points.  <b>Arc (2 points +R)</b>: arc defined by two topographic points and by the radius.  <b>Drawing object</b>: drawing element (line, polyline, arc, circle) to select in the graphic window.</p>

### Stakeout by offset referring to a line by 2 points

Line by 2 points	
<b>Point 1</b>	First point of the reference line
<b>Point 2</b>	Second point of the reference line
<b>Invert</b>	Inverts the direction of the line.
<b>Info</b>	Shows the information of the object.

### Stakeout by offset referring to an arc by 3 points

Arc by 3 points	
<b>Point 1</b>	First point of the reference arc
<b>Point 2</b>	Second point of the reference arc
<b>Point 3</b>	Third point of the reference arc
<b>Invert</b>	Inverts the direction of the arc.
<b>Info</b>	Shows the information of the object.

### Stakeout by offset referring to an arc by 2 points and radius

Arc by 2 points and radius	
<b>Point 1</b>	Starting point of the reference arc
<b>Point 2</b>	Ending point of the reference arc
<b>Radius</b>	Radius of the reference arc
<b>Clockwise arc</b>	Direction of the reference arc
<b>Invert</b>	Inverts the direction of the arc.
<b>Info</b>	Shows the information of the object.

### Stakeout by offset referring to a drawing element

It's requested to select from the graphic window the reference drawing element.

### Offset parameters

Parameters	
<b>Station</b>	Distance, on the reference element, at which is the position to reach.
<b>Interval</b>	Distance along the reference element that you want to maintain between the next stakeout points. The button on the right allows to calculate the interval dividing the length of the reference element in a defined number of parts.
<b>Offset</b>	Distance referring to reference element; the button aside allows to define if the desired position is on the right or on the left of the reference element.
<b>Height diff.</b>	Elevation difference to apply to the calculated point; the software interpolates the elevation on the reference element with the defined station distance. To the interpolated elevation can be added a slope.



Hit **Next** to start with stakeout of the calculated position.

### Stakeout procedure

After having defined the reference element and the offset parameters it appears the main stakeout window.

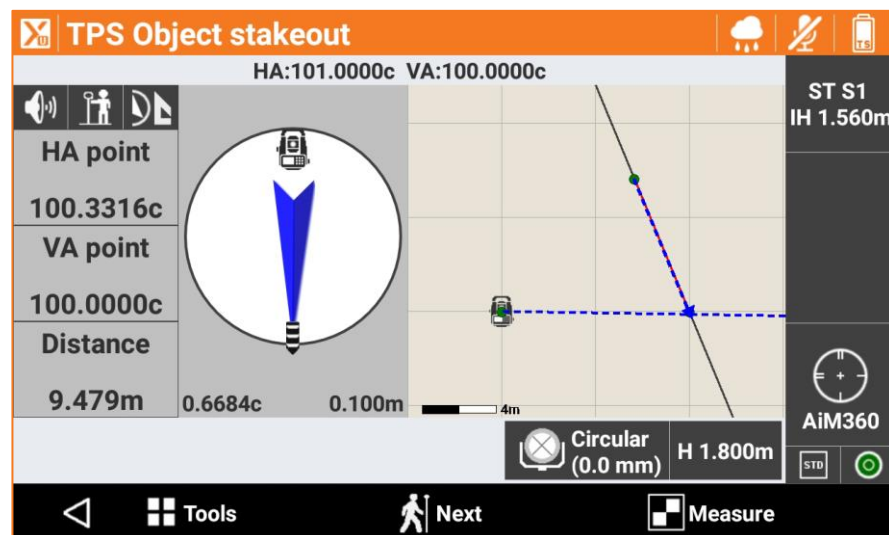
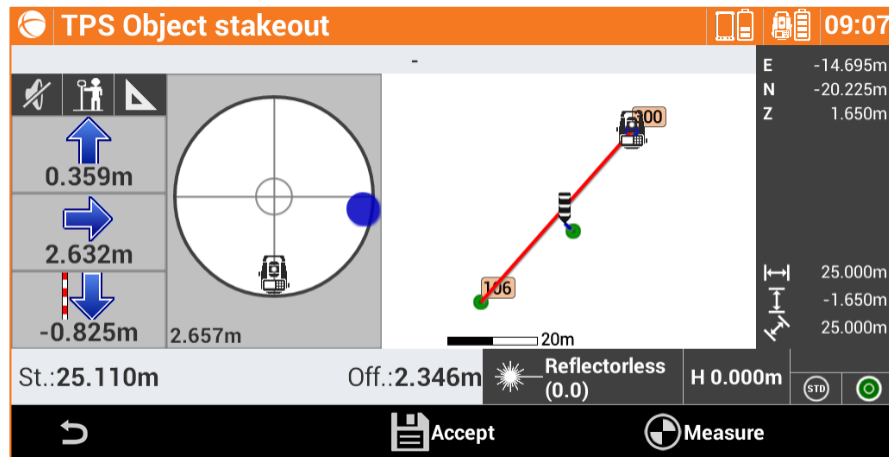

In the lower part is reported the station distance and the offset of the position.

### Stakeout of the next point by offset



Comes back to page allowing to define the station distance and the offset on the stakeout element. It is proposed a station distance increased of the interval value.

### Sideslope stakeout

This procedure allows to perform the calculation and the stakeout of the point of intersection of the design sideslope with the existing terrain; the position is calculated basing on a design slope and compared to a chainage and to a distance (offset) on a reference element.

The requests that are performed are exactly the same seen in the previous paragraph and regarding the stakeout for offset. To previous settings it's added a last card which allows you to define the design slopes in the cut and fill condition.



**Slopes**

Slopes	
<b>Cut</b>	Slope value in the cut condition (receiver elevation above the starting elevation of the sideslope).
<b>Fill</b>	Slope value in the fill condition (receiver elevation under the starting elevation of the sideslope).

**Stakeout procedure**

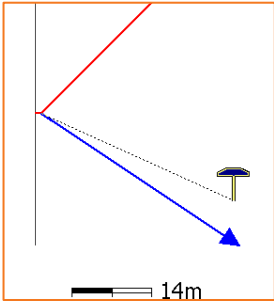
After defining the reference element, the offset parameters and slopes, it appears the stakeout main window.



In addition to the visualization modes analyzed above, this procedure provides a graphical view of the cross section which shows the design of the project sideslopes and current position. To change the visualization mode use the buttons   and .

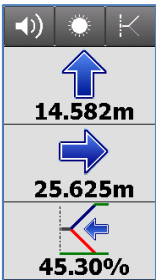

The side panel reports the information to get the point of intersection; The last information shows the current value of the slope and the direction to take, on the perpendicular to the reference element, to achieve the value of design slope. The last part of the panel can show the following information:

- Slope.
- Vertical distance from the position to project sideslope.
- Horizontal distance from the position to project sideslope.

It is possible to change the showed information, simply hit it or scroll.

**Stakeout of surfaces**

**VOLUMES**

This procedure allows to determinate on field the designed elevation of a three-dimensional surfaced loaded in current job; for every position the elevation of current position is compared with the elevation interpolated on surface and is calculated the difference of elevation. The surfaces stakeout can be used for:

- Stakeout on field of a planned surface
- Quality check to test the correspondence between the built and the plan.



Select surface to stake among the ones loaded in the job.

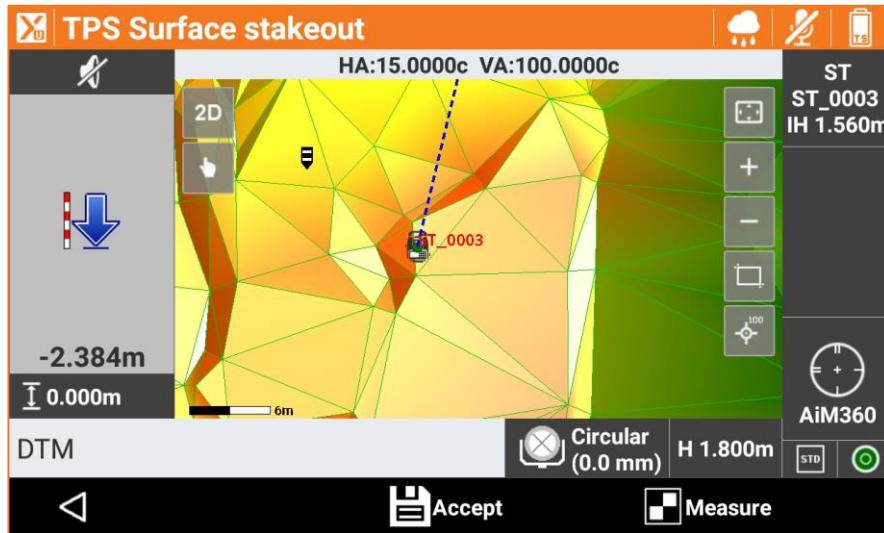

The side panel visualizes in real time the difference of elevation between current position and the elevation interpolated on the surface.

## Stakeout of BIM surface



In the graphic area select the IFC/BIM model to be checked and then proceed with the measurement. The distance between the measured point and the plane of the selected surface will be displayed.

## Stakeout report

All the stakeout data, both related to stakeout of points, both to stakeout of elements, are recorded in the job. This command allows their reading and exporting in a file with CSV extension that can be opened also with software as Microsoft Excel.



A table present the list of all the stakeout points with differences, in distances and elevations, between the design coordinate and the stakeout coordinate.

Hit button **Share** to create a file, in ASCII, CSV, XML or PDF document, with all stakeout data of every point.

# TPS – Auto Measuring

## AUTOMEASURING TPS

Auto Measuring module allows to check in real time, basing on defined parameters, movements of slopes, dams, constructions, bridges and other structures.

The Auto Measuring comes measuring reference points from which it's checked the position of the station and calculated a scale factor for the correction of the distances measured after changing of environmental factors (temperature, pressure). It follows after an automatic measure of points.

At the end of measuring session it's automatically generated a report where, for every measured point, it's possible to visualize the deviations measured in different sessions and for every session it's possible to visualize deviations in different points.

The problems found during measuring session can be notified by e-mail or SMS.

## Auto Measuring flow





To perform a correct Auto Measuring procedure (manual or automatic), follow these steps:

1. Define control points.
2. Set the station orientation basing on defined control points.
3. Measure points.
4. Start Auto Measuring procedure.

## Control points

The control points, are points needed to re-calculate the position of the station to every Auto Measuring session.



Control points			
	114	E	-2.712m
		N	-0.438m
		Z	-0.196m
	104	E	-2.173m
		N	-0.438m
		Z	-0.196m
	101	E	-1.647m
		N	3.450m
		Z	-1.111m
	102	E	-2.712m
		N	-0.439m
		Z	-0.196m

Control points: 4

Tools Add

## Inserting a new check point

Points can be inserted manually or from direct measures.



Points can be enabled or not to Auto Measuring procedure. To activate or deactivate a point, it's sufficient clicking on icon indicating the point.

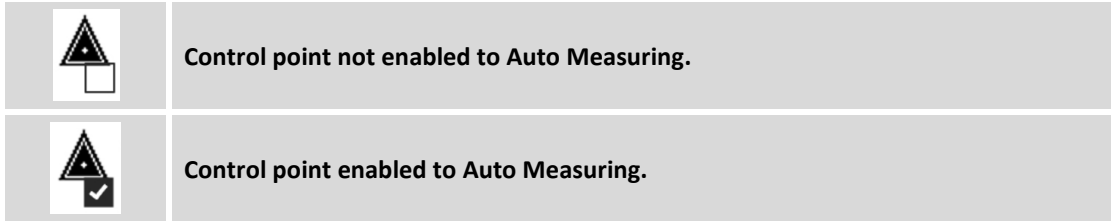

### Edit a check point

It is possible to select a check point from the table. Hit **Edit** to modify the data. In addition to the properties of the points there is the Automeasuring Tab, in that you can make the following settings.

Automeasuring	
Define Target	Enables the choice of target type for the selected check point.
Define tolerance	Enables the customization of distance and elevation tolerances for the selected check point

### Points to measure

Points to measure, are the points that will be measured and checked during the session.



Points to measure			
	140	E	-2.712m
<input checked="" type="checkbox"/>		N	-0.439m
		Z	-0.196m
	139	E	-1.647m
<input checked="" type="checkbox"/>		N	3.450m
		Z	-1.111m
	138	E	-2.712m
<input checked="" type="checkbox"/>		N	-0.439m
		Z	-0.196m
	137	E	-1.647m
<input checked="" type="checkbox"/>		N	3.450m
		Z	-1.111m
	136	E	-2.712m

Points to measure: 40

Tools + Add

## Insert a new point to measure

Inserting of the point comes through direct measuring of point and can be made after having set the station orientation.



Points can be enabled or not to Auto Measuring procedure. To activate or deactivate a point, it's sufficient clicking on icon indicating the point.

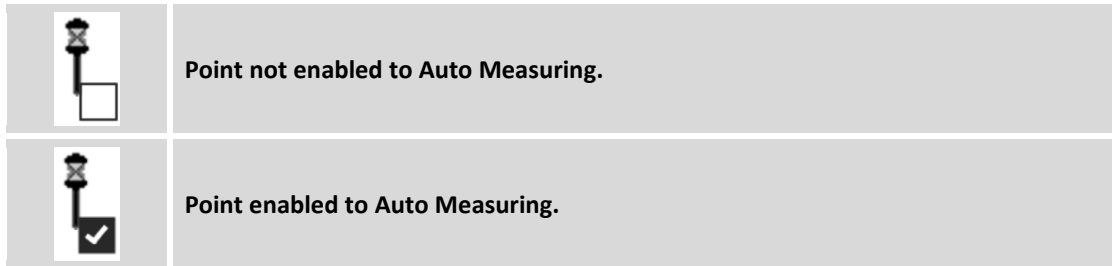

## Edit a point to measure

It is possible to select a point from the table. Hit **Edit** to modify the data. In addition to the properties of the points there is the Automeasuring Tab, in that you can make the following settings.

Automeasuring	
Define Target	Enables the choice of target type for the selected point.
Define tolerance	Enables the customization of distance and elevation tolerances for the selected point

---

## Station orientation

This procedure allows to set manually the orientation of the station.



Setup of the station orientation comes through a guided procedure requesting following data:

1. **Orientation modes.**
2. **Station Data.**
3. **Measuring of reference points.**

### Orientation mode

Orientation mode to indicate is **Free station**, where position and orientation of the station are determined by measuring of at least two reference points with known coordinates.

### Station Data

Defining of the orientation of the station, requests to indicate following data:

<b>Station</b>	Name of the station.
<b>Instr. elevation</b>	Elevation of the instrument.
<b>Code</b>	Survey code.

### Measuring reference points

In this phase, the guided procedure, asks to specify the first reference point and to perform the corresponding measuring; it's possible to type the name of the reference point or select it from table of points, from table of checkpoints. Aim the selected reference point and hit **Measure**.

It's then asked to perform the same operation for the second reference point.

Points measured are reported in a table with calculated deviations in correspondence of every point and the total standard deviation on calculation of the station position.

**Station setup**

**Measurements to reference points**

<b>H V</b> S2	ΔH: 0.000m	<input checked="" type="checkbox"/>
	ΔV: 0.000m	<input type="checkbox"/>
<b>H V</b> S3	ΔH: 0.001m	<input checked="" type="checkbox"/>
	ΔV: 0.000m	<input type="checkbox"/>
<b>H V</b> S4	ΔH: 0.001m	<input checked="" type="checkbox"/>
	ΔV: 0.000m	<input type="checkbox"/>

**Calculation executed**  
Std.Dev. E 0.0005m N 0.0003m Z 0.0001m

◀
+ Add point
✓ Accept setup

Hit **Add point** to add a measure of other reference points to improve the quality of calculation and for a better check of data.

If deviations and standard deviations are acceptable Hit **Accept setup** to complete procedure.

**Note.** During automatic measuring, the orientation of the station is automatically calculated basing on inserted checkpoints.

### Automatic Measurement



At intervals of time defined by the user it's activated the connection to the station and commanded the measure of reference points from which it's checked the position of the station and calculated a scale factor for the correction of distances measured after changing of environmental factors (temperature, pressure). It follows then the automatic measuring of the points; at the end of measuring session it's automatically generated a report that can be sent by e-mail or saved on an FTP area.



The problems found during the session (points not measured, movements over the tolerance, etc.) can be notified by e-mail or SMS.

Command	
<b>Start Measure</b>	Starts the Auto Measuring automatic procedure basing on defined parameters.
<b>Stop Measure</b>	Stops the Auto Measuring procedure.

## Single Measuring (manual)



Measure of points can be also controlled by the operator; the operations performed by the software are exactly the same of automatic mode but starting of procedure it's performed by the operator that occasionally goes on site, positions the station and starts the measuring procedure.

Command	
 <b>Measure</b>	Starts the Auto Measuring session.
 <b>Stop</b>	Stops the Auto Measuring procedure.

**Note.** During manual session, they aren't sent notifications.

## Report

This command, allows seeing results of measuring sessions. For every point it's possible to visualize the deviations measured in different sessions and for every session it's possible to visualize the deviations in different points.



### Report Points

For every point they are indicated the deviations of different sessions and the different traffic lights identify if deviations are inside the tolerance or not.



Report			
POINTS		SESSIONS	
		$\Delta Z$	0.001m
Session #184		$\Delta E$	0.019m
14-04-14 11:49:53		$\Delta N$	0.009m
		$\Delta Z$	0.001m
Session #183		$\Delta E$	0.019m
14-04-14 11:32:13		$\Delta N$	0.009m
		$\Delta Z$	0.001m
Session #182		$\Delta E$	0.019m
14-04-14 11:14:53		$\Delta N$	0.009m
		$\Delta Z$	0.001m
Session #181		$\Delta E$	0.019m
		$\Delta N$	0.009m

### Report sessions

For every session they are indicated the measured points with deviations and the different traffic lights identify if deviations are inside the tolerance or not.

Report			
POINTS		SESSIONS	
Session #100			11-04-14 14:22:46
Session #99			11-04-14 12:43:40
Session #98			11-04-14 12:41:40
Session #97			11-04-14 12:39:40
101		$\Delta E$	0.000m
		$\Delta N$	0.000m
		$\Delta Z$	0.000m
102		$\Delta E$	0.000m
		$\Delta N$	0.000m
		$\Delta Z$	0.000m

### Exporting and sharing Report

The Report can be exported and shared in every moment, by e-mail, Bluetooth, etc. in formats **CSV**, **XML** compatible with **MS-Excel** and in format **ASCII**.

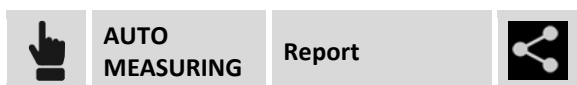



### Activity log

The procedure allows to visualize all the operations performed during the sessions of measures in chronological way.

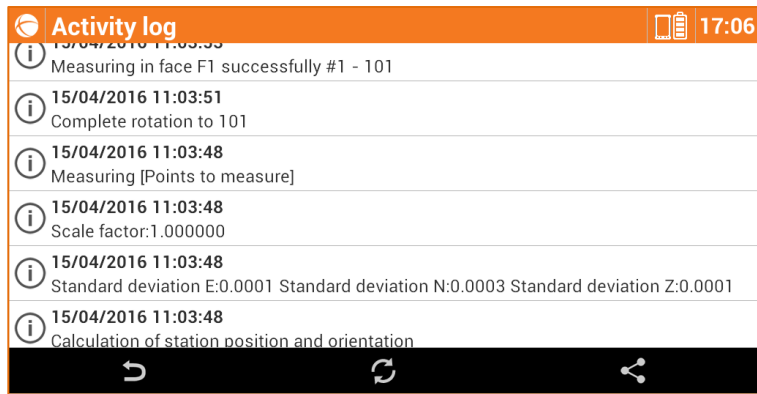





The operations visualized in the log are distinguished by type.

Type di messaggi	
 <b>Information</b>	They are the different operations performed during measurement and executed without problems.
 <b>Attention</b>	They identify eventual problems as for example the calculation of the new position of the station.
 <b>Error</b>	They identify the errors that have come during measurement. For example it's not possible connecting with the instrument.

  

Commands	
 <b>Update</b>	Updates the activity log.
 <b>Share</b>	Shares the activity log in every moment, by e-mail, Bluetooth, etc.

## Settings

The Auto Measuring procedure is subjected to several parameters and options that are fully customizable by the user.



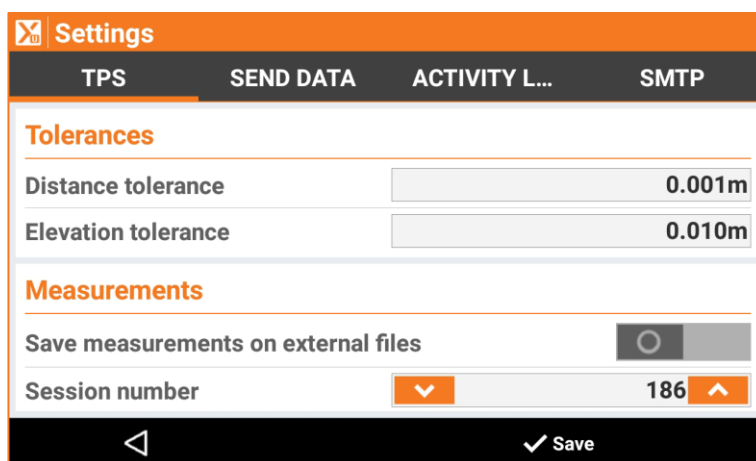

The Auto Measuring settings, are organized in pages.

#### TPS – Tolerance page

<b>Tolerance distance</b>	Maximum horizontal distance between current position and the position of the point to measure; if the distance between the current position and the position measured is more than the tolerance, the software notifies the overrun.
<b>Tolerance elevation</b>	Maximum acceptable difference between the current elevation and the elevation of the point to measure; if the difference of elevation is more than the tolerance, the software notifies the overrun.

#### TPS – Measures page

<b>Save measurements on external files</b>	Allows you to save data to a file other than the job file. This allows you not to load too much data into the current job.
<b>Session number</b>	Sets the session ID number.
<b>Face1 &amp; Face2</b>	Enables measuring of points, in face1 and face2.
<b>ATR searching mode</b>	Sets the auto-collimation state of the prism.
<b>Measures per point</b>	Number of measures to perform per point.
<b>Frequency of measuring</b>	Frequency of starting of measuring sessions: <ul style="list-style-type: none"> <li>• <b>Never:</b> automatic measuring procedure is never executed</li> <li>• <b>Every 15 minutes</b></li> <li>• <b>Every 30 minutes</b></li> <li>• <b>Every hour</b></li> <li>• <b>Every 2 hours</b></li> <li>• <b>Every 4 hours</b></li> <li>• <b>Every 8 hours</b></li> <li>• <b>1 time per day</b></li> <li>• <b>2 times per day</b></li> </ul>
<b>Reference rate</b>	Reference time of starting of measuring session. Example: Reference time: 8:00 Frequency of sending data: Every hour The measuring sessions will start from 8:00 o'clock hourly (9:00, 10:00, etc.)

### SEND DATA page –report data format

<b>Format</b>	It's possible to set the formats of exportation of session results; the software automatically generates and sends to destinations (e-mail, FTP) the files of the reports.
<b>Sessions to export</b>	Allows you to choose if to export all sessions or the last.

### SEND DATA page – Notification e-mail

<b>Notification e-mail</b>	Activates the possibility to send to an e-mail box the measures notifications.
<b>e-mail</b>	E-mail box for sending of measures notifications.
<b>Attach data</b>	Activates the possibility to attach to the notification e-mail, the Post-Processing file downloaded during the measuring session.

### SEND DATA page – Server FTP1/FTP2

<b>Use the FTP server</b>	Activates the possibility to post, in an FTP area, the Post-processing files.
<b>Host</b>	Address of the FTP server.
<b>UserID</b>	User of login to FTP server.
<b>Password</b>	Password of login to FTP server.
<b>Check connection</b>	Hitting the button <b>Check connection</b> , it's possible to check if parameters of the FTP server are correct.

### SEND DATA page –SMS notifications

<b>Use SMS notification</b>	Activates the possibility to send notifications by SMS to indicated telephone numbers.
<b>Number</b>	Telephone number to which sending notifications of eventual problems found during the sessions. The numbers can be more than one, it's sufficient separating them with character “;”. Example: 3331234567;3318901234

### ACTIVITY LOG page

<b>Send data rate</b>	Frequency of sending of the measuring activity log to a certain e-mail box. Frequency of sending: <ul style="list-style-type: none"><li>• <b>Never:</b> activity log is never sent</li><li>• <b>After each session:</b> at the end of every session it will be sent an e-mail with the activity log.</li><li>• <b>1 time per day:</b> the activity log will be sent only one time per day at 12:00 o'clock.</li></ul>
<b>e-mail</b>	E-mail box for sending of measuring activity logs.

### SMTP page

<b>Name</b>	Name of server SMTP for sending of e-mail. Example account Google SMTP server: smtp.gmail.com
<b>UserID</b>	User of login to FTP server.
<b>Password</b>	Password of login to FTP server.

---

## PicPoint – Measuring on photo

### PICPOINT

PicPoint is an innovative way of measuring points that are not directly accessible from the GPS equipment. The combination of GPS location, with the photos acquired by a calibrated camera positioned on the pole allows you to measure directly in the field but also in the office later, adding new points directly on the photo. Facades, unreachable points, edges, elements to be measured bounded by fences, etc. are all situations where PicPoint is the practical solution, fast and precise.

To use PicPoint it's necessary to have the camera to be placed in the pole, and that will be controlled by the software through Wi-Fi.

---

### Acquiring photo and position

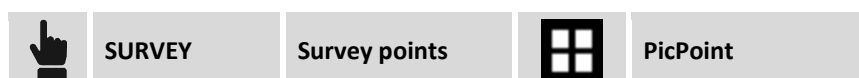

#### Camera connection

At startup of the command the Wi-Fi connection with the camera starts. When the camera is connected in the main screen it appears the camera live view. The side panel reports the status of the camera. If the camera is not connected, it's possible to click on the panel to reconnect.

Field	Description
<b>Resolution</b>	Resolution with which to operate the camera
<b>Live view wizard</b>	Enable this option to be able to see, in transparency, the photo captured in the previous step; This system helps to properly acquire the second and third photo.

If the camera is connected it's possible to click on the panel to visualize the operating parameters of the camera.

#### Measuring procedure

The measuring procedure requires the acquisition of at least three photographs and corresponding positions. The acquisition positions must form a triangle with the central vertex farther away from the subject.



Step	Description
<b>First photo and position</b>	Move to the first point of the object to be taken and frame the object to measure. Press <b>Measure</b> : the picture and the position is acquired. Press <b>Accept</b> to accept the picture; press the <b>Back</b> key to repeat the acquisition.
<b>Second photo and position</b>	Move to the second point of the object to be taken and frame the object to measure. Press <b>Measure</b> : the picture and the position is acquired. Press <b>Accept</b> to accept the picture; press the <b>Back</b> key to repeat the acquisition.
<b>Third photo and position</b>	Move to the third point of the object to be taken and frame the object to measure. Press <b>Measure</b> : the picture and the position is acquired. Press <b>Accept</b> to accept the picture; press the <b>Back</b> key to repeat the acquisition.
<b>Photo verification</b>	It appears a window in which it's possible to check the captured photos before you proceed to the main processing. Click <b>Add Point</b> to acquire a further photo and position to be used in the calculation. Press <b>Calculate</b> to start the alignment procedure of the photos; The process may take a few tens of seconds to complete
<b>Results</b>	The alignment procedure provides results on the quality of the processed result and that also influences then the subsequent measurements on the pictures. Alignment it's not possible when the system is unable to find common elements between the photos. It's important that the subject of the survey is visible the same way in the photos.

## Measuring on photos

After completing the acquisition procedure and aligning it's possible to measure new points and distances on the photos.

## New points creation

Select the **Point** button, move the photo so that the point to measure is at the center of the target. Press **Measure** to perform the measure of the point; if automatic point measure is not possible it's required to indicate the same point on the next photo.

## Distances measuring

Select button **Distance**.

Step	Description
First point	Select one of the measured topographic points or measure a new point on the photo.
Second point	Select one of the measured topographic points or measure a new point on the photo.
Results	Distance 2D, Distance 3D and elevation difference.

## Visualization options



Field	Description
Show points	It enables the visualization of topographic points of the job in the picture. They are visualized only the points that are within the photo view cone.
Show align points	Visualizes the key-points that were used for the alignment of the photographs. The covered area of the key-point is the best one to be measured.
Change photo	Allows you to choose another picture on which to perform the measures.

## Measure options



Field	Description
Measure mode	Selecting the measure mode: <ul style="list-style-type: none"><li>• <b>Auto</b>: indicate the position of the point on one of the photos; the system automatically calculates the coordinates.</li><li>• <b>Manual</b>: Specify the location of the point to be measured on two captured images</li></ul>
Automatically switches to manual measurement	If the <b>Auto</b> measure cannot be performed automatically switches to <b>Manual</b> mode with an indication of the point on two photos.
Use all photos	In <b>Auto</b> mode it's possible to use all the photos to perform the calculation and to have better control about the quality of the result.

<b>Show topographic points</b>	Allows you to set the type of points to keep visible in the photos.
<b>Epipolar line</b>	In measuring the point on the second photo (manual) it's visualized epipolar line through the point indicated on the first photo.

---

## PicPoint from the measures fieldbook

The measuring of new points on the photos can also be performed at any time after the time the photograph was taken; each measure session with PicPoint is stored in the fieldbook and it appears listed in the table.

	<b>JOB</b>	<b>Points/Measure/Codes</b>	<b>Measures page</b>
---	------------	-----------------------------	----------------------

Select the PicPoint session and choose item **Measure with PicPoint**. It appears again the window that visualizes the captured photos and allows the measuring of new points.



---

# COGO

COGO commands allow, both to create new points according to different methods, both to have information related to positions of the points as distances, angles etc., even referring to the current position of the receiver.

---

## Distances

Inverse calculates the distance, and other information, between a reference element and a base point or between a reference element and current position. The reference element can be another point, a line, an arc or a drawing element.

	COGO	Distances
---	------	-----------

Calculation method	
Reference object	Specify the reference element referring to which to execute calculation of the distance and of the other information. The reference element can be: <ul style="list-style-type: none"><li>- <b>Point</b>: distance between a base point and a reference point or between current position and the reference point.</li><li>- <b>Line (2 points)</b>: distance between a base point, or the current position, and a line passing by two points</li><li>- <b>Arc (3 points)</b>: distance between a base point, or current position, and an arc passing by three points</li><li>- <b>Arc (2 points+R)</b>: distance between a base point, or current position, and an arc passing by two points with known radius</li><li>- <b>Drawing object</b>: distance between a base point, or current position, and a drawing element to select in the graphic window</li></ul>
Antenna height	Receiver antenna elevation; the field is shown if the option <b>Current position</b> is enabled.

## Distance referring to a point

Calculation parameters	
Point 1	Reference point; it's calculated the distance between the base point and the reference point or between current position and the reference point.
Info...	Shows the coordinates of the point.

## Hit Measure

Reference point	
Current position	Enables the use of the position instrument to calculate the distance in real time. If the option is not active, the software uses the <b>Reference Point</b> setting.
Ref. point	Sets the reference point from which to calculate the distance.

Hit **Next** to execute calculation.

### Distance referring to a line by 2 points



Calculation parameters	
<b>Point 1</b>	First point of the reference line
<b>Point 2</b>	Second point of the reference line
<b>Invert</b>	Inverts the direction of the line.
<b>Info</b>	Shows the information of the object.

The command requires to perform the following operations:

- Hit **Tools** to select the first and second point of the line.
- Select one of the following options:

Reference point	
<b>Current position</b>	Enables the use of the position instrument to calculate the distance in real time. If the option is not active, the software uses the <b>Reference Point</b> setting.
<b>Ref. point</b>	Sets the reference point from which to calculate the distance.

Hit **Next** to execute calculation.

	Activates creation of a point on the projection of the base point, or of the current position, on the reference line.
	Activates stakeout procedure of the calculated position on the projection of the base point, or of the current position, on the reference line.

### Distance referring to an arc by 3 points



Calculation parameters	
<b>Point 1</b>	First point of the reference arc
<b>Point 2</b>	Second point of the reference arc
<b>Point 3</b>	Third point of the reference arc
<b>Invert</b>	Inverts the direction of the arc.
<b>Info</b>	Shows the information of the object.

The command requires to perform the following operations:

- Hit **Tools** to select the first, the second and the third point of the arc.
- Select one of the following options:

Reference point	
<b>Current position</b>	Enables the use of the position instrument to calculate the distance in real time. If the option is not active, the software uses the <b>Reference Point</b> setting.
<b>Ref. point</b>	Sets the reference point from which to calculate the distance.

Hit **Next** to execute calculation.

	Activates creation of a point on the projection of the base point, or of the current position, on the reference arc.
	Activates stakeout procedure of the calculated position on the projection of the base point, or of the current position, on the reference arc.

### Distance referring to an arc by 2 points and radius



Calculation parameters	
<b>Point 1</b>	Starting point of the reference arc
<b>Point 2</b>	Ending point of the reference arc
<b>Radius</b>	Radius of the reference arc
<b>Clockwise arc</b>	Direction of the reference arc
<b>Invert</b>	Inverts the direction of the arc.
<b>Info</b>	Shows the information of the object.

The command requires to perform the following operations:

- Hit **Tools** to select the first and the second point of the arc and the radius of the arc.
- Select one of the following options:

Reference point	
<b>Current position</b>	Enables the use of the position instrument to calculate the distance in real time. If the option is not active, the software uses the <b>Reference Point</b> setting.
<b>Ref. point</b>	Sets the reference point from which to calculate the distance.

Hit **Next** to execute calculation.

	Activates creation of a point on the projection of the base point, or of the current position, on the reference arc.
	Activates stakeout procedure of the calculated position on the projection of the base point, or of the current position, on the reference arc.

### Distance referring to a CAD element

It's requested to select from the graphic window the reference drawing element referring to which to calculate distance from the base point or from current position or from a reference point.

If the selected element is a polyline, the program asks whether to use the selected segment or the entire object.

Hit **Next** to execute calculation; it's shown the distance and other values calculated in real time basing on the position of the receiver.



Activates creation of a point on the projection of the base point, or of the current position, on the reference element.



Activates stakeout procedure of the calculated position on the projection of the base point, or of the current position, on the reference element.

## Reference line

This procedure allows to obtain the information regarding the current position with reference to geometric elements such as lines, arcs or design elements.



COGO

Reference line

It's possible to define the reference element in different ways.

### Reference

#### Reference

Allows you to choose the modes with which to define the reference element. The possible options are:  
**Line (2 points)**: line defined by two reference topographic points.  
**Arc (3 points)**: arc defined by three reference topographic points.  
**Arc (2 points +R)**: arc defined by two topographical points and the radius.  
**Drawing object**: design element (line, polyline, arc, circle) to select in the graphic window.

## Line by 2 points

### Line by 2 points

<b>Point 1</b>	First point of the reference line
<b>Point 2</b>	Second point of the reference line
<b>Invert</b>	Inverts the direction of the line.
<b>Info</b>	Shows the information of the object.

## Arc by 3 points

### Arc by 3 points

<b>Point 1</b>	First point of the reference arc
<b>Point 2</b>	Second point of the reference arc
<b>Point 3</b>	Third point of the reference arc
<b>Invert</b>	Inverts the direction of the arc.
<b>Info</b>	Shows the information of the object.

## Arc by 2 points and radius

Arc (2 points+R)	
Point 1	Start point of the reference arc
Point 2	End point of the reference arc
Radius	Radius of the reference arc
Arc clockwise	Direction of the reference arc
Invert	Inverts the direction of the arc.
Info	Shows the information of the object.

## CAD element

It's requested to select from the graphic window the drawing element to stakeout. After it is possible to insert a offset value. You can apply it right or left by clicking the direction buttons.





## Offset





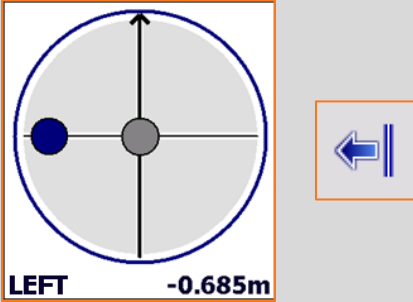

After defining the reference element it's possible to specify an additional offset to the right or to the left.

Offset	
Offset	Distance to be maintained referring to the reference element

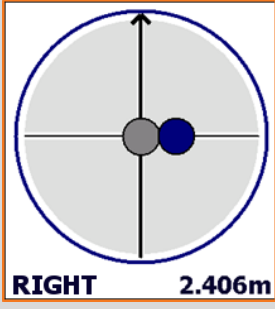

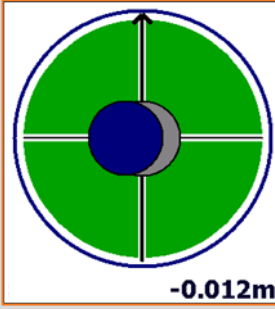
Rotation angle	
Rotation angle	Allows you to add a rotation angle to the reference element.

## Reference line

Icon	Stakeout information
	Distance from the beginning of the reference element. Press  to visualize the distance from the end of the element.
	Distance from the end of the reference element. Press  to visualize the distance from the end of the element.
	The current position is on the left referring to the reference element

		<p>The current position is on the right referring to the reference element</p>
		<p>The current position is on the reference element.</p>
	<p>The elevation is on the reference elevation.</p>	
	<p>The current elevation is under the reference elevation.</p>	
	<p>The current elevation is above the reference elevation.</p>	

### Elevation difference

Icon	Description
	<p>The reference elevation is calculated on the reference element</p>
	<p>The reference elevation is the elevation at the beginning of the reference element</p>
	<p>The reference elevation is the elevation at the end of the reference element</p>

### Graphic and analytic visualization

To pass from graphic to analytic visualization use buttons  .

## Distance & Offset

Distance & offset calculates coordinates of a point along a reference element and at a certain distance from it.

**Reference****Reference**

Select the reference element among following options:

- **Line (2 points)**: line passing by 2 points
- **Arc (3 points)**: arc passing by 3 points
- **Arc (2 points+R)**: arc passing by 2 points with known radius
- **Drawing element**: drawing element to select in the graphic window

**Distance & offset – Line (2 points)**

<b>Point 1</b>	First point of the reference line
<b>Point 2</b>	Second point of the reference line
<b>Invert</b>	Inverts the direction of the line.
<b>Info</b>	Shows the information of the object.

**Distance & offset – Arc (3 points)**

<b>Point 1</b>	First point of the reference arc
<b>Point 2</b>	Second point of the reference arc
<b>Point 3</b>	Third point of the reference arc
<b>Invert</b>	Inverts the direction of the arc.
<b>Info</b>	Shows the information of the object.

**Distance & offset – Arc (2 points + R)**

<b>Point 1</b>	Starting point of the reference arc
<b>Point 2</b>	Ending point of the reference arc
<b>Radius</b>	Radius of the reference arc
<b>Clockwise arc</b>	Direction of the reference arc
<b>Invert</b>	Inverts the direction of the arc.
<b>Info</b>	Shows the information of the object.

**Distance & offset – Drawing element**

Select from the graphic window the reference drawing element.



Hit **Next** to proceed with the guided procedure.

**Parameters**

<b>Distance along</b>	Distance on which to position the point along the reference element
-----------------------	---

<b>Offset on right</b>	Lateral distance at which to position the point referring to the reference element
<b>Offset direction</b>	Position, right or left, of the point referring to reference element
<b>Elevation diff.</b>	Elevation difference to apply to the interpolated elevation of the point

Hit **Next** to proceed with calculation of the position of the point; the coordinates of the point and a graphic preview of the position are shown.

	Activates creation of the calculated point.
	Activates stakeout procedure of the calculated position.

## Intersection

Intersection calculates coordinates of a point on the intersection between straight lines and circumferences definable in different ways.

	<b>COGO</b>	<b>Intersection</b>
--	-------------	---------------------

Method	
<b>Method</b>	Select the method to use for intersection calculation: <ul style="list-style-type: none"> <li>- <b>Double distance</b>: the intersection position is calculated basing on the two distances referring to two reference points</li> <li>- <b>Distance and azimuth</b>: the intersection position is calculated basing on the distance from a reference point and along a straight line passing by the second reference point</li> <li>- <b>Double azimuth</b>: the intersection position is calculated on the intersection of two straight lines passing by two reference points</li> <li>- <b>4 points</b>: the intersection position is calculated on the intersection of two straight lines passing by four reference points</li> </ul>

### Intersection Double distance

The intersection position is calculated basing on the two distances referring to two reference points.

Intersection – First point	
<b>Point 1</b>	First reference point
<b>Distance 1</b>	Distance from first reference point



Hit **Next** to proceed with the guided procedure.

Intersection – Second point	
<b>Point 2</b>	Second reference point



<b>Distance 2</b>	Distance from second reference point
-------------------	--------------------------------------

Hit **Next** to proceed with calculation of the position of the point; the two possible solutions are shown: select on the graphic window the desired solution.

	Activates creation of the calculated point.
	Activates stakeout procedure of the calculated position.

### Intersection Distance and azimuth



The intersection position is calculated basing on the distance from a reference point and along a straight line passing by the second reference point.

Intersection – First point	
<b>Point 1</b>	First reference point
<b>Distance 1</b>	Distance from first reference point

Hit **Next** to proceed with the guided procedure.

Intersection – Second point	
<b>Point 2</b>	Second reference point
<b>Azimuth</b>	Azimuth of the straight line passing by the point
<b>Offset</b>	Offset distance referring to the straight line passing by the point
<b>Offset direction</b>	Offset direction, right or left, referring to the straight line passing by the point

Hit **Next** to proceed with calculation of the position of the point; the two possible solutions are shown: select on the graphic window the desired solution.

	Activates creation of the calculated point.
	Activates stakeout procedure of the calculated position.



### Intersection double azimuth

Intersection – First point	
<b>Point 1</b>	First reference point
<b>Azimuth</b>	Azimuth of the straight line passing by the point
<b>Offset</b>	Offset distance referring to the straight line passing by the point
<b>Offset direction</b>	Offset direction, right or left, referring to the straight line passing by the point

Hit **Next** to proceed with the guided procedure.

Intersection – Second point	
<b>Point 2</b>	Second reference point
<b>Azimuth</b>	Azimuth of the straight line passing by the point
<b>Offset</b>	Offset distance referring to the straight line passing by the point
<b>Offset direction</b>	Offset direction, right or left, referring to the straight line passing by the point

Hit **Next** to proceed with calculation of the position of the point; the coordinates of the calculated point are shown.

	Activates creation of the calculated point.
	Activates stakeout procedure of the calculated position.



### Intersection 4 points

Intersection – First rect	
<b>Point 1</b>	First reference point of the first straight line
<b>Point 2</b>	Second reference point of the first straight line
<b>Offset</b>	Offset distance referring to the straight line passing by the two points
<b>Offset direction</b>	Offset direction, right or left, referring to the straight line passing by the two points

Hit **Next** to proceed with the guided procedure.

Intersection – Second rect	
<b>Point 1</b>	First reference point of the second straight line
<b>Point 2</b>	Second reference point of the second straight line
<b>Offset</b>	Offset distance referring to the straight line passing by the two points
<b>Offset direction</b>	Offset direction, right or left, referring to the straight line passing by the two points

Hit **Next** to proceed with calculation of the position of the point; the coordinates of the calculated point are shown.

	Activates creation of the calculated point.
	Activates stakeout procedure of the calculated position.

---

## Area subdivision

The command is able to execute a subdivision of area on a surface defined by a polyline, by a parcel or by a sequence of points. The subdivision line can be parallel or perpendicular to two reference points.

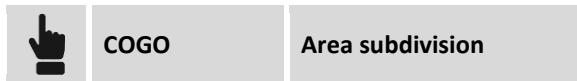

Element to divide	
Contour of area	Select the contour defining the area to subdivide.

Hit **Next** to proceed with the guided procedure.

Dividing line	
Method	Specify position of the division line referring to the reference points: <ul style="list-style-type: none"><li>- <b>Parallel to 2 points</b>: the division line will be parallel to reference points.</li><li>- <b>Perpendicular to 2 points</b>: the division line will be perpendicular to reference points.</li></ul>
Point 1 and Point 2	Reference points referring to which to calculate the position of the division line.
Select area to subdivide	Select, in the graphic preview, the area referring to which to calculate the area to subdivide.

Hit **Next** to proceed with the guided procedure.

Subdivision – Area to divide	
Type of area	Mode with which to define value of the area to subdivide: <ul style="list-style-type: none"><li>- <b>Value</b>: value of the area to subdivide.</li><li>- <b>% Percentage</b>: value in percentage of the area to subdivide.</li></ul>
Total area	Area of the defined surface.
Area (value)	Value of the area to subdivide.
Area (%)	Value in percentage of the area to subdivide.

Hit **Next** to view the position of the crossing points: select on the graphic window the crossing point to record or to use for stakeout.



	Activates creation of the calculated point.
	Activates stakeout procedure of the calculated position.

---

## Area & Length

The command can perform the calculation of the areas and lengths during the surveying operation.



You can view other 2D/3D data by hitting  / 

Areas and lengths	
<b>2D perimeter</b>	Show the level length of the perimeter.
<b>3D perimeter</b>	Show the 3D length of the perimeter.
<b>2D length</b>	Shows the level length of the line joining the points.
<b>3D length</b>	Shows the 3D length of the line joining the points.

The software requires to hit **Measure** to perform the measurements of the points, which define the surveying zone.

It is possible cancel the last stored point by hitting **Delete last**.

---

## Check planes

The checks commands allow you to perform quick controls of drawing elements or measured positions in the site. The checks may concern elevations, distances, angles or surfaces.



Method	
<b>Mode</b>	<p>Set the level on which to perform the elevation check:</p> <ul style="list-style-type: none"><li>- <b>Horizontal level:</b> checks the elevation difference between the measured and the horizontal reference level.</li><li>- <b>Vertical level:</b> performs distance control, using the difference between the measured distance and the distance to vertical reference level.</li><li>- <b>Level with 1 slope:</b> checks the elevation difference between a defined level by applying a gradient along a reference direction and the current measured elevation.</li><li>- <b>Level with 2 slopes:</b> checks the elevation difference between a defined level, which has a longitudinal and transverse slope, and the measured current elevation.</li><li>- <b>Level by 3 points:</b> checks the elevation difference between a reference level and the measured current elevation. The reference level is defined by measuring three references points.</li></ul>
<b>Antenna height</b>	Receiver antenna elevation; the field is shown if the option <b>Current position</b> is enabled.

### Control of elevations on horizontal level

This command allows to check the elevation difference between the reference elevation and the current measured elevation by the instrument; the software uses a horizontal level passing through the reference elevation to perform the control.

Horizontal level	
Reference elevation	Sets the reference elevation to use for the elevation check. Hit <b>Measure</b> or <b>Select</b> .
Measure	Hit <b>Measure</b> to measure the current elevation and use this as the reference elevation.

In real time is displayed the difference between the current measured elevation by instrument and the reference elevation. The software also shows the distance and slope between the reference point and the current position.

### Control of elevations on vertical level

This command allows to check the elevation difference between the reference elevation and the current measured elevation by the total station. The software uses a vertical level passing through the reference points.

Vertical level	
Reference elevation	Sets the reference elevation to use for the elevation check. Hit <b>Measure</b> or <b>Select</b> .
Measure Point #1	Hit <b>Measure</b> to measure the point which sets the direction of vertical axis.
Measure Point #2	Hit <b>Measure</b> to measure the second reference point.

In real time is displayed the difference between the current measured elevation by instrument and the reference elevation. The software also shows the distance and slope between the reference point and the current position.

**The command is only available for TPS measurements.**

### Control of elevation on level with one slope.

This command allows to check the elevation difference between a defined level by applying a gradient along a reference direction and the current measured elevation.

The command requires to perform the following steps:

Level with 1 slope	
1	Measure or select the axis origin point along which to apply the slope. Hit <b>Measure</b> or <b>Select</b> .
2	Measure the position which sets the direction of the axis along which has to be applied the slope. Hit <b>Measure</b> .
3	Set the longitudinal slope on set axis.

In real time is displayed the difference between the current measured elevation by instrument and the reference elevation. The software also shows distances from the origin, compared to the reference line and the slope.

### Control of elevation on level with two slopes

This command allows to check the elevation difference between a defined level and the current measured elevation by instrument. The reference plane is defined by applying a first slope on a reference axis and a second slope on the axis perpendicular to it.

The command requires to perform the following steps:

Level with 2 slopes	
1	Measure or select the axis origin point along which to apply the slope. Hit <b>Measure</b> or <b>Select</b> .
2	Measure the position which sets the direction of the axis along which has to be applied the slope. Hit <b>Measure</b> .
3	Set the values of longitudinal and transverse slopes on the defined axis.

In real time is displayed the difference between the current measured elevation by instrument and the reference elevation. The software also shows distances from the origin, compared to the reference line and the slope.

### Control of elevation on level by three points

This command allows to check the elevation difference between a defined level and the current measured elevation by instrument. The reference plane is set by measuring three reference points.



The command requires to perform the following steps:





Level by 3 points	
1	Measure or select the first point of the level. Hit <b>Measure</b> or <b>Select</b> .
2	Measure or select the second point of the level. Hit <b>Measure</b> .
3	Measure or select the third point of the level. Hit <b>Measure</b> .

In real time is displayed the difference between the current measured elevation by instrument and the reference elevation. The software also shows the distance and slope between the reference point and the current position.

### Display of elevation controls

After the reference plane has been created, symbols appear at the bottom of the relief window.

Symbols	Information
	The current elevation is lower than the reference elevation.
	The current elevation is upper than the reference elevation.

	The current elevation is on the reference elevation.
	Shows the distance on the X axis of the plane to the measured point.
	Shows the distance on the Y axis of the plane to the measured point.
	Shows the slant distance from the point to the point of origin of the plane.
	Shows the slope of the measured point compared to the origin of the plane.

## Move, Rotate & Scale

The command is able to perform different roto translations and transform the points and the drawing elements.



You can perform the transformation in the following ways:

Transformation mode	
Mode	<ul style="list-style-type: none"> <li>- <b>Manual entry:</b> allows you to insert rotation and scale shifting values to transform points and selected objects.</li> <li>- <b>Matching points:</b> allows to create a list of matching points used to calculate the parameters to transform points and selected objects.</li> </ul>

### Manual entry

The command is divided into pages and requires the entry of parameters to perform the transformation.

Page 1	
$\Delta E/\Delta N/\Delta Z$	Requires to entry the shifting value of the three axes.
Page 2	
Rotation angle	Requires to entry the rotation value.
Point	Requires to entry or select the reference point to perform the rotation and scaling. It is possible hit > to select the point.
E/N	Entry the coordinates of the reference point.
Page 3	
Scale	Requires to entry the scale value.

<b>Point</b>	Requires to entry or select the reference point to perform the rotation and scaling. It is possible hit > to select the point.
<b>E/N</b>	Entry the coordinates of the reference point.

### Page Select points/objects

<b>All points</b>	The transformation is applied to all points of current job.
<b>Select points</b>	The transformation is applied to the points selected from the list of topographic points.
<b>All points/drawings</b>	The transformation is applied to all points and drawing objects of current job
<b>Select points/drawings</b>	Allows to select from the CAD view the point and the drawing objects that have to be transformed.
<b>Only drawings</b>	The transformation is applied to all drawing entities of current job.

### Page Save options

<b>Overwrite points/drawings</b>	The points and the drawing objects are updated with the new calculated positions.
<b>Backup job and Overwrite points/drawings</b>	The software stores a backup of current job without transformation; the points and the drawing objects are updated with the new calculated positions in the current job.
<b>Save as new points</b>	The points with the new calculated positions are stored as new points in the current job.
<b>Prefix</b>	Allows to set the prefix for the points that will be stored if you select the option <b>Save as new point</b> .

## Matching points

Pairs of matching points can be used to calculate transformation parameters. The transformation applied may be one of the following:

### Calculation method

<b>Rigid</b>	Performs one rotation and one barycentric translation.
<b>Conformal</b>	Performs the fitting of the survey based on the set reference points. A barycentric transformation and a scale factor are applied.

Hit  button to entry a new point and entry the required data:

### Add point

<b>Source</b>	Allows you to select the source point. You can perform the operation in the following ways: <ul style="list-style-type: none"> <li>- <b>Select position from CAD:</b> allows to select the point from the cad windows;</li> <li>- <b>Select point:</b> allows to entry the point name.</li> </ul>
<b>Select point</b>	Allows to select the name of the point or the position..



<b>Target</b>	Allows you to select the reference point. You can perform the operation in the following ways: <ul style="list-style-type: none"> <li>- <b>Select position from CAD:</b> allows to select the point from the cad windows;</li> <li>- <b>Select point:</b> allows to entry the point name.</li> </ul>
<b>Select point</b>	Allows to select the name of reference point or the position.
<b>Use HV</b>	Allows to select the calculation parameters that will be used. <ul style="list-style-type: none"> <li>- <b>H+V:</b> the coordinates will be used to perform the horizontal and vertical transformation.</li> <li>- <b>Only H:</b> the coordinates will be used to perform only the horizontal transformation.</li> <li>- <b>Only V:</b> the coordinates will be used to perform only the vertical transformation.</li> <li>- <b>None:</b> the values of transformation will not be used.</li> </ul>

Hit **Add** and repeat the operation for the other matching points.  
Then press **Next** and select the transformation method.

Page Select points/objects	
<b>All points</b>	The transformation is applied to all points of current job.
<b>Select points</b>	The transformation is applied to the points selected from the list of topographic points.
<b>All points/drawings</b>	The transformation is applied to all points and drawing objects of current job
<b>Select points/drawings</b>	Allows to select from the CAD view the point and the drawing objects that have to be transformed.
<b>Only drawings</b>	The transformation is applied to all drawing entities of current job.

Hit **Next** and choose the save options.

Page Save options	
<b>Overwrite points/drawings</b>	The points and the drawing objects are updated with the new calculated positions.
<b>Backup job and Overwrite points/drawings</b>	The software stores a backup of current job without transformation; the points and the drawing objects are updated with the new calculated positions in the current job.
<b>Save as new points</b>	The points with the new calculated positions are stored as new points in the current job.
<b>Prefix</b>	Allows to set the prefix for the points that will be stored if you select the option <b>Save as new point</b> .

# Volumes and surfaces

## VOLUMES

The Volumes module allows the calculation of material movement according to different modes and considering a triangular three-dimensional surface built starting from points present in the archive or imported from different formats.

## Surfaces

The surface is the necessary element to proceed with the volumes calculation; it's possible to create and manage different surfaces inside the same job archive.

The surface can be calculated automatically by the software basing on the points present in the archive and on the defined breaklines. The surface can be also created and modified manually allowing, this way, to obtain a result the most similar to the real surface improving the calculation results.

The surfaces can be represented in different ways: only with lines, with shading, with color basing on the elevation, with contour lines.



The table reports the list of all the surfaces present in the archive. For every surface are reported the minimum and maximum elevation, the 2D surface and the 3D surface.

### Creating a surface











Properties	
Name	Name to assign to the surface
Style	Representation style of the surface; the available styles are: <ul style="list-style-type: none"><li>- <b>Wireframe</b>: are drawn the segments of the triangles composing the surface</li><li>- <b>Shade</b>: the faces of the triangles are colored basing on the direction of light exposure</li></ul>
Color	Color to use to represent the surface: <ul style="list-style-type: none"><li>- <b>Original</b>: it's used the color of the layer containing the triangles.</li><li>- <b>By elevation (terrain)</b>: the faces are colored basing on the elevation of the center of gravity; the color scale starts from green, passes through yellow and ends with red.</li><li>- <b>Surface</b>: it's used a color that can be chosen in the field <b>Surface color</b>.</li><li>- <b>By elevation (sea)</b>: the faces are colored basing on the elevation of the center of gravity; the color scale starts from green, passes through blue and ends with white.</li></ul>
Surface color	Color to use to represent the surface if the option <b>Color from surface</b> is chosen.

Points and lines	
<b>Manual triangulation</b>	Activate this option to build manually the triangles composing the surface.
<b>Points</b>	<p>In case of automatic building it's necessary to specify the set of points to use. Press the button on the right of the input field to access the list of points or to a menu allowing to select points.</p> <p>Options are the following:</p> <ul style="list-style-type: none"> <li>- <b>Load all points:</b> all points present in the archive are used to calculate the surface.</li> <li>- <b>Select from table:</b> it's possible to select points from the points table.</li> <li>- <b>Select from CAD:</b> allows to select points from the graphic window.</li> <li>- <b>Delete points list:</b> allows to delete the points loaded as vertexes of triangles</li> </ul>
<b>Breaklines</b>	<p>To check the shape of the surface it's possible to specify some breaklines; the breaklines have to be previously inserted, as polylines, in the graphic window.</p> <p>Press the button on the right of the input field to access to a menu allowing to:</p> <ul style="list-style-type: none"> <li>- <b>Select from CAD:</b> select breaklines from the graphic window</li> <li>- <b>Clear all:</b> delete the previously selected breaklines.</li> </ul>
<b>Contours</b>	<p>To border the surface it's possible to specify some contour lines; the contour lines must have been previously inserted, as polylines, in the graphic window.</p> <p>Hit button in the right of the input field to access to a menu that allows to:</p> <ul style="list-style-type: none"> <li>- <b>Select from CAD:</b> select the contour lines from graphic window</li> <li>- <b>Delete all:</b> delete the previously selected contour lines.</li> </ul>
 <b>Accept</b>	<p>Hit <b>Accept</b> to proceed to calculation of the surface. At the end of calculation the surface is visualized inside a specific graphic viewer.</p> <p>If it has been activated the option <b>Manual Triang.</b> no calculation is performed but it is activated the graphic viewer that reports the points present in the archive; use the commands of the viewer to build and modify the surface.</p>

## Surfaces editing

To edit the shape of the triangles composing a surface select the corresponding line in the list of surfaces and press the **View** button. The commands of the graphic viewer allow to edit the surface.

Command		
	 <b>Data</b>	 Allows to edit parameters of the visualization of the surface.
	 <b>New</b>	Allows to build a new triangle; it's requested to indicate the three points composing the triangle.
	 <b>Swap</b>	Exchange the direction of the faces of two triangles having a common side.
	 <b>Delete</b>	Allows to select triangles to delete.



## Visualization of surface on Google Map



To visualize the surface on Google Map it's necessary to define a coordinate system allowing the transformation of the coordinates in the system WGS84 used by Google Map.

## Visualization of surface in 3D



Command		
	 <b>Data</b>	 Allows to modify parameters of visualization of the surface.
	 <b>Views</b>	Allows to select one of the preset views using the cube faces.

## Surface visualization parameters

To edit the visualization parameters of a surface select the corresponding line in the list of the surfaces and press the **Properties** button.

Properties	
<b>Name</b>	Name to assign to the surface
<b>Style</b>	Representation style of the surface; the available styles are: <ul style="list-style-type: none"> <li>- <b>Wireframe</b>: are drawn the segments of the triangles composing the surface</li> <li>- <b>Shade</b>: the faces of the triangles are colored basing on the direction of light exposure</li> </ul>
<b>Color</b>	Color to use to represent the surface: <ul style="list-style-type: none"> <li>- <b>Original</b>: it's used the color of the layer containing the triangles.</li> <li>- <b>By elevation (terrain)</b>: the faces are colored basing on the elevation of the center of gravity; the color scale starts from green, passes through yellow and ends with red.</li> <li>- <b>Surface</b>: it's used a color that can be chosen in the field <b>Surface color</b>.</li> <li>- <b>By elevation (sea)</b>: the faces are colored basing on the elevation of the center of gravity; the color scale starts from green, passes through blue and ends with white.</li> </ul>
<b>Surface color</b>	Color to use to represent the surface if the option <b>Color from surface</b> is chosen.

Contour lines	
Contour lines	Activates the visualization of the contour lines of the surface.
Contour step	Contour step to use to draw the contour lines.
Contour color	Color to use to draw the contour lines.

### Deleting a surface

To delete a surface select the corresponding line in the list of the surfaces and press the **Delete** button.

### Performing the stakeout of a surface

From window listing surfaces it's possible to pass directly to procedure of stakeout; the procedure of stakeout of surfaces allows to determinate, in every position, the difference of elevation between the existing ground and the surface planned.

To pass to procedure of stakeout select the line of surface to stake and select the item **Stakeout**.

### Surfaces importing



It's possible to import still defined surfaces from files in DXF or LandXML format. Press **Tools** button and select the format to use to import. Select then the file to import; the surface is reported in the table.

### Viewing the surfaces in the CAD

In the main graphic window it's possible to manage the visualization of the surfaces present in the archive.



The appearing table reports the list of the present surfaces; to show or hide a surface click on the

symbol  or on  .

Always from the table it's possible to modify visualization parameters or to pass to stakeout procedures

by hitting .

### Volume calculation

It's possible to perform several volumes calculations and maintain the obtained results both as calculated values both as graphic representation also.



The table reports the list of all calculated volumes. For every calculated volume are reported information as the type of calculation used and the volumes of cut and fill.

### Volume referring to a reference elevation

This mode allows to obtain the volume existing between a reference surface and an horizontal plane to an established elevation.

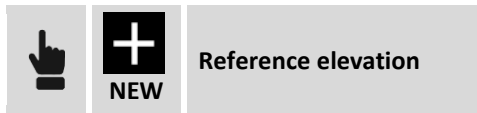

#### Volume calculation

**Reference elevation** Reference elevation referring to which to execute the volume calculation

### Volume referring to a reference point

This mode allows to obtain the existing volume between a reference surface and an horizontal plane at an established elevation by a reference point.

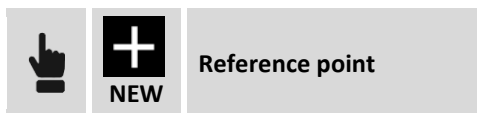

#### Volume calculation

**Reference point** Point of the archive referring to the elevation of which to execute the volume calculation

### Volume of a stockpile/pit

This mode allows to calculate the volume of a stockpile or of a pit; the software calculates referring to the reference surface, a second surface considering only the points present in the perimeter of the reference surface. It's then determined the volume present between the reference surface and a second surface representing the bottom, in case of stockpile, or representing the "top", in case of pit.



Set the calculation parameters and hit **Accept** to continue in the procedure.

### Volume referring to a reference plane

This mode allows to calculate the volume between a reference surface and a plane passing by three points.



Volume calculation	
<b>Point 1</b>	First reference point referring to which to calculate the project plane
<b>Point 2</b>	Second reference point referring to which to calculate the project plane
<b>Point 3</b>	Third reference point referring to which to calculate the project plane

Press **Next** to proceed in the guided procedure.

### Calculation parameters

After having selected the type of calculation and set the corresponding parameters are requested the following data:

Volume calculation	
<b>Name</b>	Name to assign to elaboration
<b>Cut swell factor</b>	Expansion factor for the cut volumes. The expansion factor can be inserted manually or chosen from a list of preset materials.
<b>Calculate weight</b>	Activates the calculation of the weight of the material excavated and filled considering the specific weight
<b>Weight (t/m3)</b>	Specific weight in tons per cubic meter. The specific weight can be inserted manually or chosen from a list of preset materials.
<b>Auto adjust cut/fill</b>	In the case of volume calculation with reference plane, it is possible to activate the adjustment of cut and fill; keeping the defined slopes of the plane, plane is moved vertically to balance cut and fill volumes.
 <b>CALCULATE</b>	It's proposed the list of surfaces present in the archive; select the surface reference referring to which performing the volume calculation.

At the end of the calculation all results are reported both concerning volumes both concerning cut and fill surfaces.

Press **View** to access to graphic visualization of calculated volumes; in the graphic visualization the color of triangles depends on the elevation difference in cut and fill; it's applied a gradation of color starting with red for the maximum excavation zones, passing by the yellow for the zones with no excavation nor filling, and ends with green for the zones of maximum filling.

### Viewing calculated data

To access to the information of an elaboration, and to graphic visualization select **Details** item.

Calculated data	
<b>Details</b>	Detailed list of data of the elaboration; button <b>Report</b> allows to obtain a report in different formats of calculated data.
<b>View</b>	Graphic visualization of the elaboration; areas in red are referred to a pit zone instead areas in green are referred to a zone of stockpile. A button in the toolbar allows to activate the query mode: by clicking on graphic area it displays the cut and fill differences.

### Deleting a calculated volume

To delete an elaboration select the corresponding line in the list of volumes and select **Delete** item.



---

## Roading – roads stakeout

### ROADING

X-PAD Roding is a module that allows to manage road design data in the field and perform all the necessary stakeout operations without to use point coordinates but by using original design data. The user is free to stakeout and to have road design information at any stations.

Road design data can be imported from LandXML format or from local road design software data format and the complete design can be managed directly on the controller; it is possible to manage more than one axis at the same time and all design data are displayed in plan view, longitudinal profile view and cross-section view.

It is possible to work in three different ways:

- **Cross-sections at specific stations:** in this case at any stations the interpolated cross-section is calculated
- **Road edge polylines:** cross-sections are calculated, at any stations, from the intersection with road edge polylines
- **Cross-sections templates:** one or more cross-section template can be applied along the center line; cross-section template can be fully customized by the user by defining the cross-section shape and also additional information as superelevations and widenings.

It is possible to stakeout the road design data and sideslopes at any station and with any offset; the point to stakeout can be easily specified on the cross-section view and your current position is displayed in three different views: plan, longitudinal profile, cross-sections.

A useful command called “Where am I ?” allow to have all design information about your current position along the road: station, offset, horizontal alignment element, vertical alignment element, elevation difference from design elevation and from current surface.

If Roding module is used together Volume & Surface module, it is possible to stakeout road design data and use a tridimensional design model (surface) as reference for the elevations.

---

### Road manager

Road manager is the control panel of all the data of the road project. They are listed all axes and all the side polylines that have been loaded; the project data can be imported from different formats.



### Importing road project from LandXML format



Select the LandXML file to import. All axes and the side polylines will be loaded and visualized in the list.

### Importing road axis from DXF file



Polylines in the DXF file are imported and become road axes only with the planimetric development without longitudinal profile or sections; They can be used for stakeout, but without reference to the elevations.

### Transformation of a polyline into a road axis or side polyline



Select a polyline in the graphic window to transform it into the road axis with planimetric development without longitudinal profile or sections; the axis can be used for stakeout, but without reference to the elevations.

### Importing road project from local format



You can select one of the following kind of format file. All axes and edge polylines will be loaded and displayed in the list.

The supported formats are:

- CLIP (Spain).
- ISTRAM/ISPOL (Spain).
- Fiksu (Finland).
- XRoad (Finland).

### Editing a road axis

It's not possible to edit the project elements of the horizontal and vertical track (profile) but it's possible to integrate the design with additional information such as the section models to be used, the raising and widening in curves.

Select the axis to be edited and choose **Edit** item.

The project data is divided into tabs.

#### Road tab

Field	Description
<b>Name</b>	Name of the axis
<b>Start Station</b>	Chainage of beginning of the axis
<b>East North</b>	Coordinates of the starting point of the axis

#### Planimetric axis tab

The tab lists the planimetric elements of the project; the graphic window visualizes the planimetric track. The selected project element is brought to the forefront in the graphic window.

### Longitudinal profile tab

The tab lists the longitudinal elements of the project; the graphic window visualizes the altimetry track. The selected project element is brought to the forefront in the graphic window.



### Cross sections tab

The tab lists the cross sections of the project. To obtain the list of the coordinates of the lines and vertexes that compose the section select item **View**: a new window reports the list of vertexes for each section element that compose the section.

It is possible hit:



This command activates the sequential display of the cross sections.

Field	Description
Station	Sets the station from which to start the sequence. When the sequence is started the station of the axis is displayed in the preview.
Interval	Set the station interval.
	Activates the sequence.
	Stop the sequence.

### Section models tab

The tab allows to specify the models of section to be used along the track; the defined section model will be applied by the chainage of application until the end of the track, or until the next interval.

Field	Description
Chainage	Chainage from which to start the application of the section model
Left	Section model to be used on the left side of the section
Right	Section model to be used on the right side of the section

### Superelevations tab and widenings tab

The tab allows to specify the superelevations (Side Slope) and widenings to be used in the elements of the section model.

Field	Description
Chainage	Chainage to which refer the values of superelevation and widening
Left	Left superelevation and widening
Right	Right superelevation and widening

Once the models of section to be used and the superelevation values have been defined the program is able to determine for any chainage the project cross-section: by the chainage it's obtained the model

section and they are interpolated values of superelevation and widening that are applied to the corresponding elements of the section model.

Values of superelevation and widening calculated are applied only to the elements of the model section that are identified as items to rotate and enlarge.

### Road sides tab

The tab allows to define, among all polylines of side, those which belong to the axis and which must be used to obtain the cross section. At each chainage the program performs an intersection with the side polylines to obtain the cross section to be used in stakeout.

### Deleting a road axis



Select axis, or side polyline, from the list and choose item **Delete**; all axis data will be deleted.

---

## Stakeout

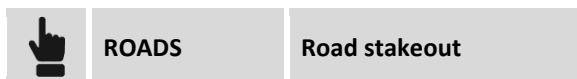
Stakeout of a road axis is quite similar to stakeout of an element by chainage and offset; after having selected the reference axis specify the chainage and the stakeout distance.



Field	Description
Chainage	Stakeout chainage
Interval	Interval to use for the chainage increase
Surface	If there are cross-sections it's possible to specify the section line to be used for stakeout
	Activates the display preview of planimetric alignment elements.
	Activates the display preview of longitudinal profile
	Activates the display preview of cross sections.

According to the entered chainage it's interpolated and visualized the corresponding cross-section. On the calculated section specify the distance from the axis; it's possible to select the vertex also from graphic view.

Field	Description
Offset	Vertex of the section to stakeout
Offset	Distance from the axis; it's possible to add an additional offset
Elevation	Elevation of stakeout; it's possible to add an additional vertical offset

After defining the chainage and offset the procedure continues with the same functions explained in the chapter on stakeout.

---

## Sideslope stakeout

The procedure allows to perform the calculation and the stakeout of the point of intersection of the project sideslope with the existing terrain; the position is calculated on the basis of a slope of project and referring to a chainage and to a distance (offset) on the reference axis.



The requests that are performed are exactly the same seen in the previous paragraph. To the previous settings it's added a last tab that allows you to define the project slopes in the cut and fill condition. The slopes are applied on the point defined as chainage and offset from the reference axis.

### Slopes

Slopes	
Cut	Slope value in the cut condition (receiver elevation above the starting elevation of the sideslope).
Fill	Slope value in the fill condition (receiver elevation under the starting elevation of the sideslope).
Slope from segment	The slope value is calculated according to the selected segment. The sideslope is therefore considered as an extension of the segment.

### Stakeout procedure

After defining the reference element, the offset parameters and slopes, it appears the main stakeout window.

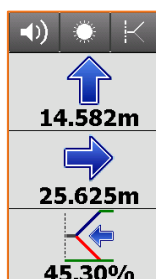
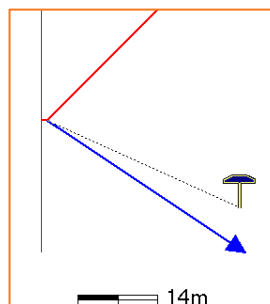

The side panel contains the information to get the point of intersection; The latest information reports the current value of the slope and the direction to take, on the perpendicular to the reference element, to achieve the value of project slope.

The last part of the panel can show the following information:

- Slope.
- Vertical distance from the position to project sideslope.
- Horizontal distance from the position to project sideslope.

It is possible to change the showed information, simply hit it or scroll.

---

## Where am I ?

This function is able to provide much information concerning the current position referring to the selected road project.

Select the reference axis to be used for the calculation. In case of use of the total station start measure to have a position of calculation.

Basing on the position they are visualized the following information:

Description
Chainage in which you are located
Distance from the reference axis
Element of the planimetric track
Element of the altimetry track
Absolute elevation / Axis elevation / Elevation difference
Right or Left side of the track

They are available three graphic views: planimetry, profile and section.

## X-Sections Templates

The section models define the shape and the characteristics of the section to be applied along a track; through the composition of simple linear elements it's also possible to define models of complex sections that may be subject to superelevations and widenings in curves.

The section model must be defined only for the right side of the section but the definition can also be used for the left side.

### Adding a section model

On the **General** tab, it's possible to set the section model name and distance of the point of rotation.

Field	Description
Name	Name of the section model
Rotation Point	<p>Distance of the point of rotation referring to the central axis of the project:</p> <ul style="list-style-type: none"> <li><b>double pitch roadway:</b> the point of rotation coincides with the axis of the road and so the distance of the point of rotation is 0</li> <li><b>separated roadways with rotation of roadways at the inner edge:</b> the distance of the point of rotation coincides with the width of the internal edge</li> <li><b>separated roadways with rotation in correspondence of the axis of each roadway:</b> the distance of the point of rotation corresponds to the width of the inner edge plus the width of the half-roadway</li> </ul>

In **Vertexes** tab it have to be defined the section shape.

Each vertex is defined by the horizontal and vertical distance referring to the previous vertex:

Field	Description
Type	Type of input: <ul style="list-style-type: none"><li>• <b>Offset X &amp; Y</b>: horizontal and vertical distance</li><li>• <b>Offset X &amp; Slope</b>: horizontal distance and slope</li></ul>
Offset X	Horizontal vertex distance from previous vertex
Offset Y	Vertical vertex distance from previous vertex
Slope	Slope of the vertex from previous vertex
Apply Superelevation & Widening	Enable to be able to have applied on this segment the superelevation and widening values. To enable for parts which represent the roadway.

### Editing a section model

Select model and choose item **Modify**.

### Deleting a section model

Select model and choose item **Delete**.

---

## Stakeout report

All the stakeout data, both related to stakeout of points, both to stakeout of elements, are recorded in the job. This command allows their reading and exporting in a file with CSV extension that can be opened also with software as Microsoft Excel.



A table present the list of all the stakeout points with differences, in distances and elevations, between the design coordinate and the stakeout coordinate.

Hit button **Share** to create a file, in ASCII, CSV, XML or PDF document, with all stakeout data of every point.

---

## X-Live – Collaborative survey

X-Live is the innovative "collaborative survey" system that, through X-PAD, allows a data communication within a group that uses daily topographic instruments. X-Live allows the creation of working groups and sessions of measures to which the team members can participate and exchange instant messaging, measured points, coordinate systems, jobs files or generic files.

All activity takes place within and through X-PAD that visualizes with notifications for incoming messages and allows the sending of the necessary data to other team members. Even office workers can participate in activities using X-PAD Office MPS.

---

### Creating an X-Live connection



Each connection is characterized by a group name and password that allows team members to access to group sessions. Each user is identified by a full name and an abbreviation.

Field	Description
Group name	Group name
Password	Password to access the group
User name	Complete name of the user that is performing connection
User abbreviation	Abbreviation of the user that is performing connection

Confirm to create group.

---

### Connecting to an X-Live connection



To access a group that has already been created it's necessary to specify the name and password of access in addition to your identification data (user name and user abbreviation).

---

### Disconnecting from an X-Live connection



---

### Using the Chat

when an X-Live connection is active it's possible to access to chat in which can happen the exchange of messages and files.



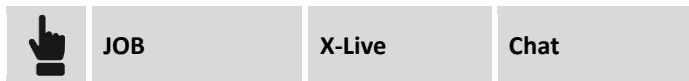

Moreover it's possible to access the chat directly from the top bar of the application where it appears the symbol of the chat.

Icon	Description
	Allows to access to chat.
	New messages arrived and allows to access to chat.

### Sending messages

To send a message to all participants of the group, type the text in the field and press **Send**.

### Sharing files

To send a file to all participants of the group it's necessary to define in X-Live settings the cloud server that will be used to store the files so that they can be downloaded from the group members. At first access will be required to log in to the cloud server via e-mail address and password; passed this step select the file to send, add a message, if any, and proceed sending. The file will download to the cloud server and the members of the group will receive a message clicking on which they will proceed to download on their controller.

---

### Sending points with X-Live



Select the points to share and proceed sending. A file containing the coordinates of the selected points will be downloaded to the cloud server and the members of the group will receive a message clicking on which they will proceed to load the points directly in the list of points of their job.

---

### Coordinates systems sending with X-Live

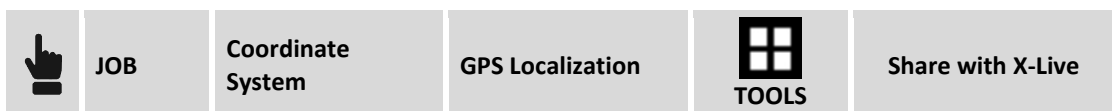

The current coordinate system will be sent, through the cloud server, to all members of the group who will receive the notification. Clicking on the notification, the coordinate system will be downloaded and set as the current job coordinate system.

---

## Sharing points measured in real time

In addition to chat and real-time sharing of messages, points, coordinate systems and generic files it's possible to enable the function of collaborative survey that allows, during the survey phases, to share the points measured with members of the group who have active the same function.



Field	Description
Session name	Name of measure session; all users must type the same session name.
Share measured points	Enables real-time sharing of measured points with other users of the working group. Other users will receive the measured points.
Receive measured points	Enables receipt of measured points by other members of the working group.
Share my position	Enable sharing current position with other users of the workgroup.
Receive users position	Enables receipt of the position of other members of the working group.

From the moment of the collaborative Survey session, according to the previous settings, it's possible to send your points, share your position, receive points from other users and receive their position.

---

## Settings

The X-Live settings allow you to define several parameters and system operating rules.



## Options

Field	Description
Share measured points	Enables real-time sharing of measured points with other users of the working group. Other users will receive the measured points.
Receive measured points	Enables receipt of measured points by other members of the working group.
Share my position	Enable sharing current position with other users of the workgroup.
Receive users position	Enables receipt of the position of other members of the working group.

## Export options

Field	Description
<b>Export points</b>	Enables the export also of the points that have been received as a sharing by others in the group. If this option is active, the export functions of the points are able to export not only the points acquired by the operator but also current points acquired by other operators.

## Cloud-server options

Field	Description
<b>Cloud server</b>	X-Live allows sharing of various file types; to allow the sharing files are loaded into a cloud server and the users of the group is sent a link that allows them to download the file itself. To allow this process it's necessary to define the Cloud server to use as the copy area of the files to be shared.

---

## External references

External references are connections that are created between the current job and other jobs of X-PAD, other data files in AutoCAD DXF format or raster maps.

Instead of importing definitively data within the current job it's possible to manage the reference to the data and load it temporarily only when needed; when opening the main job they can be loaded data also of linked files.

External reference is therefore a very flexible way of managing the data required for the phases of the job because they allow you to load only what you need without changing the main file; they allow you to always load the updated version of the reference file and finally allow you to share the same reference files between multiple jobs.

The elements of the imported document as an external reference cannot be modified.

After defining a reference to an external file it's possible:

- **Download data:** the reference remains active but the data are downloaded from the memory
- **Load data:** load the data file in memory
- **Change visibility status:** make the external reference data visible or invisible
- **Restore link:** if the external reference file has been moved to a new folder, it's possible to specify the new location and to restore the connection.



---

### Adding an external reference



It adds a new reference to an external document that will be uploaded along with the current job.

Field	Description
X-PAD Document AutoCAD DXF/DWG Raster map	Select the type of document to be added as an external reference

### Importing an AutoCAD DXF file or an X-PAD job

Select folder and file to load.

Field	Description
Mode	It's possible to choose whether to import all the data of the selected document into a single layer or whether to keep the original layer
Layer	Only one layer to use to group the document data
Layer color	Color of layer

<b>Use original colors</b>	It's possible to load all the data on a single layer and continue to maintain the original color of the drawing
<b>Import points</b>	It adds points of the document list to the jobs points
<b>Points prefix</b>	Prefix to be added to the names of the points loaded from the document

**The DWG drawings with cartographic coordinates are not supported. In this case it is required to use the AUTOCAD DXF format.**

### Import an IFC file (Industries Foundation Classes)

BIM

The IFC format file (Industries Foundation Classes) is the reference for the BIM methodology. Files of this type have a data structure divided into classes; each class contains objects. Using an IFC file as an external reference makes available in the CAD window all the classes and objects, that are in the IFC file. In the Project manager it is possible to handle the visibility status of a class or objects.

### Importing a raster image

Select folder and file of the image to load.

Position and scale	
<b>Top-left corner</b>	Coordinates of the top-left corner in which to position the image
<b>Scale map 1:</b>	Scale factor to assign to map for correct representation
<b>Map width</b>	Width of the image in real coordinates
<b>Map elevation</b>	Elevation of the map in real coordinates

If file of the image comes with the World file, the positioning parameters allowing to visualize the image in the correct position and dimension are just visualized.

---

### Deleting an external reference

Select the document, and select item **Delete** from the menu that appears. The external document data will be downloaded and the reference to the external document will be deleted.

---

### Loading external reference data

Select document, and select item **Load** from the menu that appears. The external document data will be loaded into the current document.

---



### Downloading data of an external reference

Select the document, and select item **Unload** from the menu that appears. The data will be downloaded in the current document and the memory cleaned; the reference to the external document remains.

---

## Changing visibility status of an external reference

The data for each external document can be made visible or invisible in the graphic window. Visible

documents are marked with symbol  while non-visible documents are marked with symbol  . To change the visibility status of a document click on the symbol.

---

## Reconnecting an external reference

An external document can change the storage path and be present in another folder. To recover the link select the document and then select item **Connect** from the menu that appears: Specify the new file path.

---

## Data import

Import procedures allow to load points, drawings and other information from files in several format types. Files to import can be present in device folders or on servers Cloud.

---

### Importing from file in AutoCAD DXF/DWG format

A DXF file containing drawing information and points can be loaded in the current job.



Select DXF file to load; several different import options regarding topographic points are proposed:

Imports as topographic points	
<b>Drawing points</b>	Activates import of drawing points (POINT entity) as topographic points.
<b>Blocks</b>	Activates import of block reference (INSERT entity) as topographic points.
<b>Recognize name</b>	Activates automatic recognition of the name of the point through research of a text near the point; for every point to import the software checks if it exists a text near the position of the point; the text eventually found is identified as the name of the point. So it's possible to import points from drawings in DXF format maintaining the original name of the point.
<b>Object vertexes</b>	Activates automatic creation of topographic points on objects vertexes.
<b>Start name</b>	Nome to assign to the first point that will be imported.

Import options	
<b>Invisible layers</b>	Allows you to import layers that are not visible in the CAD file.

<b>Select layers to import</b>	Allows you to choose the layers that will be imported; instead of importing all the layers a subsequent window lets you choose which layers should be imported.
<b>Import 3D</b>	Activates the import of CAD entities also with information related to the elevation. If this option is not active, all entities are imported with a 0 elevation.
<b>Distance unit</b>	Set the unit of measure of the drawing. During the import the software performs the conversion in the unit of the job.

## Importing from file in ASCII format



It's possible to import a file of points in text format as topographic points or reference points. Import parameters can be saved in a scheme which can be loaded directly in next import and export procedures.

	JOB	Import data	Text file (ASCII)
---	-----	-------------	-------------------

Select the text file to load; import options are the following:

Parameters	
<b>Data</b>	Select if you want to load the points as topographic points or as reference points. <ul style="list-style-type: none"> <li>- <b>Topographic points</b></li> <li>- <b>Reference points</b></li> <li>- <b>Codes</b></li> </ul>
<b>Scheme</b>	It is proposed import schemes currently available; choose one scheme or choose * <b>Customized</b> * to proceed to creation of your own schema.
<b>Separator character</b>	Character separating content of the fields.
<b>Heading rows</b>	Number of rows composing heading of the file and which will therefore not be imported.
<b>Overwrite points</b>	The existing points are deleted during the import phase.

The table reports the list of the fields that can be imported; if it has been selected the scheme \* **Custom** \* it's possible to select fields to import and change the order of importing of a field using buttons.

Fields	
	Select fields to import
	Move up selected field
	Move down selected field

A preview of importing result is visualized.

Save scheme	
Save scheme	If it has been selected the * <b>Customized</b> * scheme it's possible to save settings in a scheme.
Name scheme	Name of the scheme to create
	Start import procedure

**Note.** Import/export schemes are saved in files with **PSC** extension in **Schemes** folder of the software.

### Importing from files in GSI format

It's possible to import a file of points in GSI format.



Select the GSI file to load; specify if to import data as topographic points or as reference points

### Importing from files in LandXML format

It's possible to import a file of points in LandXML format.



Select the LandXML file to load.

### Importing from files in ESRI Shape format

It's possible to import a file in format ESRI Shape; they can be imported points, polylines and polygons.



Select Shape file to load.

### Importing from file in Trimble DC format

It's possible to import a file in Trimble DC format; They can be imported points and calibrations of the GPS site.



Select file to load.



---

## Importing a raster map

Allows to import a map in raster format; if the file of the image comes with the Word file they are visualized positioning parameters allowing to visualize the image in the correct position and dimension.



Select the folder and the file of the image to load.

Position and scale	
Top-left corner	Coordinates of the top-left corner of the image
Scale map 1:	Scale with which the image is acquired
Map width	Width of the map in real coordinates
Map elevation	Elevation of the map in real coordinates

The image is visualized in the graphic window of the CAD.

---

## Importing from file in SurvCE RW5 format

It's possible to import a file in SurvCE RW5 format; They can be imported points and calibrations of the GPS site.



Select file to load.

---

## Importing from file in Sokkia SDR format

It's possible to import a file in Sokkia SDR.



Select file to load.

## Export & share data

Export procedures allow to export points, drawings and other information on files in several format types to be used on other applications. It's possible exporting, sharing and open directly the files generated;

Export & share	
<b>Device/Cloud</b>	The file it's exported on the controller or it's saved on Cloud platforms; if it's saved on controller it's requested to indicate the folder in which to save the file.
<b>Sharing</b>	The file can be sent to other users in different ways: <ul style="list-style-type: none"><li>- E-mail</li><li>- Bluetooth</li><li>- WiFi</li><li>- Other modes available on controller</li></ul>
<b>Open with</b>	For some file it's possible proceeding opening and visualizing directly with apps available on controller.

---

### Exporting on file in X-PAD Office Fusion format

The points of the job and the drawing can be exported to X-PAD Office MPS format

	<b>JOB</b>	<b>Export &amp; share</b>	<b>X-PAD Office Fusion</b>
---	------------	---------------------------	----------------------------

All job files, including images associated with the points, are combined into a single file with XPAD extension and that can be imported from Office software X-PAD Office MPS.

---

### Exporting on file in AutoCAD DXF format

The points of the job and the drawing can be exported in AutoCAD DXF format.

	<b>JOB</b>	<b>Export &amp; share</b>	<b>AutoCAD DXF</b>
---	------------	---------------------------	--------------------

Other	
<b>Version</b>	DXF format version to create.
<b>Export survey drawing</b>	Activate the export of all the drawing elements that were created during the measure operations with SmartDrawing.
<b>Export drawing</b>	Activates exporting of the drawing of the job.
<b>Export 3D</b>	Activates exporting of data with elevation.

Points	
<b>Export points</b>	Activates exporting of the topographic points.

<b>Label size</b>	Size of the texts of the labels of the topographic points.
<b>As blocks</b>	Activates exporting of the topographic points as AutoCAD blocks with attributes.
<b>Export sketches</b>	Activates the export of the images associated with the points; the images are linked to the points to be opened as a reference (hyperlink) from AutoCAD.
<b>Export X-Live points</b>	Activate the export of measured points also by the other members of the team X-Live and that have been shared in the session.

## Exporting on file in ASCII format

It's possible to export topographic points, reference points and TPS measures in ASCII customizable format. Export parameters can be saved in a scheme which can be loaded directly in next import and export procedures.

	<b>JOB</b>	<b>Export &amp; share</b>	<b>Text file (ASCII)</b>
---	------------	---------------------------	--------------------------

### Parameters



<b>Data</b>	Select type of data to export: <ul style="list-style-type: none"> <li>• Topographic points</li> <li>• Reference points</li> <li>• Measures GPS</li> <li>• Measures TPS</li> <li>• Bathymetric session</li> </ul>
<b>Scheme</b>	The actually available export schemes are proposed; select a scheme or select * <b>Customized</b> * to create your own scheme.
<b>Separator character</b>	Character separating content of the fields.
<b>Heading row</b>	Activates exporting of a heading row containing the name of the fields.

### Decimals

<b>Angles</b> <b>Coordinates</b> <b>Elevation</b> <b>Distances</b>	It's possible to export data with a number of decimal different from what defined in the settings and normally used by the application.
---	---

The table reports the list of fields that can be exported; if it has been selected the scheme \* **Customized** \* it's possible selecting the fields to export and change the order of exportation of a field using buttons.

### Fields

	Select fields to export
	Move up selected field



Move down selected field

A preview of exporting result is visualized.

### Save scheme

**Save scheme**

If it has been selected the \* **Customized** \* scheme it's possible to save settings in a scheme.

**Name scheme**

Name of the scheme to create



Start procedure of exporting

**Note** Import/export schemes are saved in files with PSC extension in **Schemes** folder of the software.

## Exporting on file in GSI format

It's possible to export topographic points, reference points and TPS measures in GSI format.



JOB

Export & share

GSI format

### Parameters

**Data**

Select type of data to export:

- Topographic points
- Reference points
- TPS Measures

**Export model**

If the data to be exported is Topographic points or TPS measurements, you can choose in export model:

Topographic points:

- Points for Phytagoras
- Points for CodeGrafik (rmData)

TPS measurements:

- TPS measurements Phytagoras
- TPS measurements LSS
- TPS measurements CodeGrafik (rmData)

**Export attributes**

Activating this option the code of the point is exported as attribute of GSI format

**Separator**

Separator used for composed codes; in the code of the point it's possible to save more single codes separated by a character as point, comma, space or other. During exportation of attributes the complete code is divided in sub-codes basing on separation character used.

**Unite attributes**

Activating this option the single codes composing the complete code are exported as a single code; the separation character is not considered.

Hit **Export** to start exportation.

---

## Exporting on file in LandXML format

It's possible exporting topographic points and reference points in LandXML format.

	JOB	Export & share	LandXML Format
---	-----	----------------	----------------

---

## Exporting on file in Google Earth KML/KMZ format

It's possible exporting topographic points and reference points in KML format for Google Earth.

	JOB	Export & share	Google Earth KML/KMZ
---	-----	----------------	----------------------

### Options

<b>Format</b>	Chooses the KML or KMZ export format. The KMZ format can also export images.
<b>Altitude mode</b>	Elevations can be defined in three ways: <ul style="list-style-type: none"><li>• Clamp to ground: elevation is however leaned to 3D model of Google Earth</li><li>• Relative to ground: elevations are referred to 3D model of Google Earth</li><li>• Absolute: elevations are absolute</li></ul>
<b>Export GIS attributes</b>	Enables export of GIS attributes if present.
<b>Export images</b>	Activates the export of the images present in the job.
<b>Image type</b>	Choose the type of image to export: <ul style="list-style-type: none"><li>• Sketch</li><li>• Original</li><li>• Tag Image</li></ul>

If Google Earth is installed in your device it's also possible opening and visualizing the content of the file.

---

## Exporting on file in Garmin GPX format

It's possible exporting topographic points and reference points in Garmin GPX format.

	JOB	Export & share	Garmin GPX format
---	-----	----------------	-------------------

---

## Exporting on file in ESRI Shape file format

It's possible exporting topographic points and reference points in ESRI Shape file format.

	JOB	Export & share	ESRI Shape file format
---	-----	----------------	------------------------

You can choose whether to export coordinates in plane format (ENZ) or as latitude, longitude, altitude (LLH).

---

### Exporting on file in Leica IDX/IDEX format

It's possible exporting topographic points and reference points in IDX/IDEX format.



---

### Exporting on file in Sokkia SDR format

It's possible exporting topographic points and reference points in Sokkia SDR format.



---

### Exporting on file in SurvCE RW5 format

It's possible exporting topographic points and reference points in SurvCE RW5 format.



---

### Exporting on file in STAR\*NET format

It's possible exporting the TPS measures in STAR\*NET format.



---

### Exporting measures

There is no explicit function to export measures acquired on the field due to information non – uniformity existing among GPS measures, hidden points measures, total station measures etc. However, every time a job is closed, it is created automatically the X-PAD RAW file; the RAW file is a text file reporting the main settings of the job, the coordinates of the points and the chronologic list of the measures acquired with all the available information.

**To use measures and survey data with third party software we suggest using the RAW file.**

For further information about RAW file X•PAD format please refer to corresponding guide.

---

### Exporting in other formats

Data exports are available in many different formats according also to the selected language. Also new export formats are constantly being added.



# X-PAD

U L T I M A T E

